



# MAKE-UP AIR SOLUTIONS

## AIRLET™ TL98

### Manually Adjustable Fresh Air Inlet

PRODUCT SPECIFICATIONS & TECHNICAL DATA

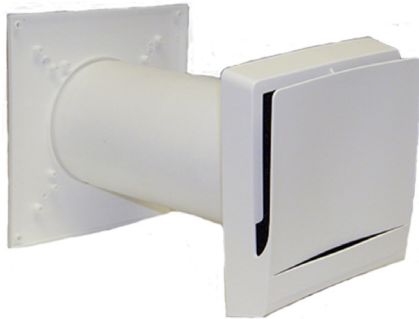

CONDENSATION- PREVENTION DESIGN

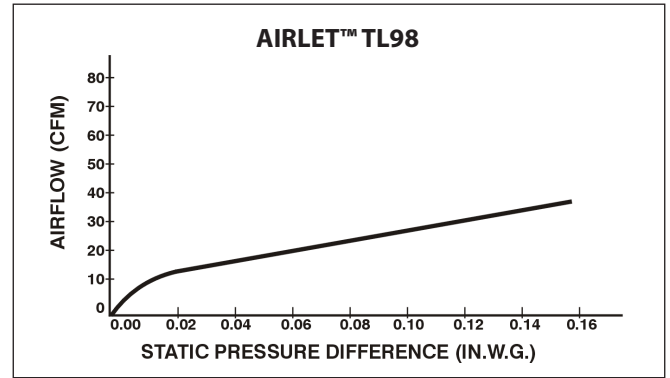
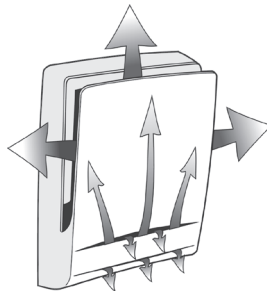

#### DESCRIPTION

The AIRLET™ TL98 manually adjustable fresh air inlet incorporates a unique, variable, precision-control damper that provides superior comfort control for the user. The damper is manually adjusted using a discreet slide control accessible from behind the front cover, which prevents unwanted tampering.

The interior grille is both attractive and multi-functional. The slightly arched grille face and horizontal lower slot take advantage of air currents to provide condensation protection. The superior air-distribution pattern ensures draft-free performance.

Every AIRLET™ TL98 includes an expandable wall sleeve, an exterior louver, and a permanent, washable filter that is easily accessible for cleaning. The white color blends well with any decor, and the unit can be cleaned with a damp cloth. Pollen filters and sound-absorbing wall sleeves are also available.

BACK SIDE OF INTERIOR GRILLE

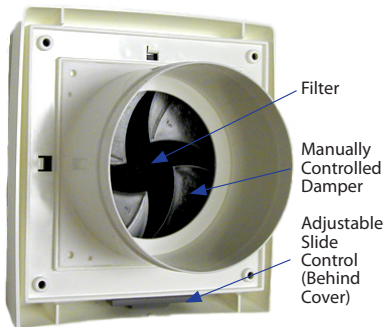

#### UNITS & ACCESSORIES

P/N: 13 550	AIRLET™ TL98 Complete (4"-8" Sleeve)
P/N: 13 201	4" Sleeve Expansion Section
P/N: 13 102	Pollen Filter (Optional)
P/N: 13 101	Standard Filter (Replacement)
P/N: 13 552-12	Sound-Absorbing Sleeve (For walls 5"-12" thick)

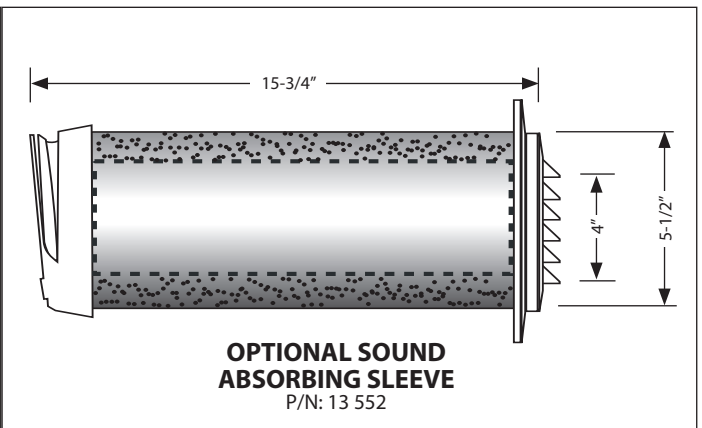
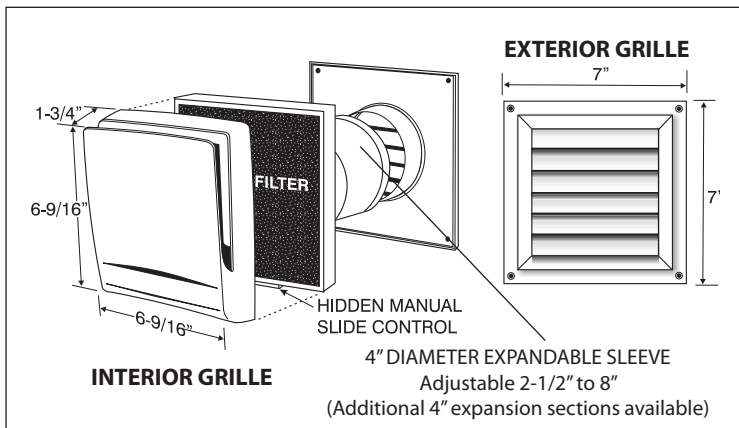

© 2014 American ALDES Ventilation Corporation. Reproduction or distribution, in whole or in part, of this document, in any form or by any means, without the express written consent of American ALDES Ventilation Corporation, is strictly prohibited. The information contained within this document is subject to change without prior written notice.