



VENTZONE® SYSTEMS



VENTZONE® VZ ZONED INTERMITTENT BATH EXHAUST ACCESSORY KITS

RESIDENTIAL SYSTEM SOLUTIONS

IOM

Product Description

ALDES North America VentZone® Systems VZ Zoned Bath Exhaust Kits* are the most advanced zoned central exhaust ventilation kits on the market. The Zone Register Terminals (ZRT-1) provides powerful-yet-silent zone controlled exhaust ventilation from bathrooms that are in use. Each VZ kit can support 2-5 bathrooms, and an expansion kit is available for up to 3 additional bathrooms. * Recommended Fan MPVS150 sold separately.

Number of Bathrooms	6" ZRT-1 (120 VAC)	4" ZRT-1 (120 VAC)	RECOMMENDED FAN Sold separately ENERGY STAR Certified* Ventilator
			
2	1	1	MPVS150
3	1	2	MPVS150
4	1	3	MPVS150

Additional Accessory	
28 550	Zone Terminal Fan Control Center (ZTC) Controls up to (8) 24 VAC ZRT (50 VA Class II Transformer)* <i>*ZRTs will be converted to 24V units instead of the standard 120V.</i>

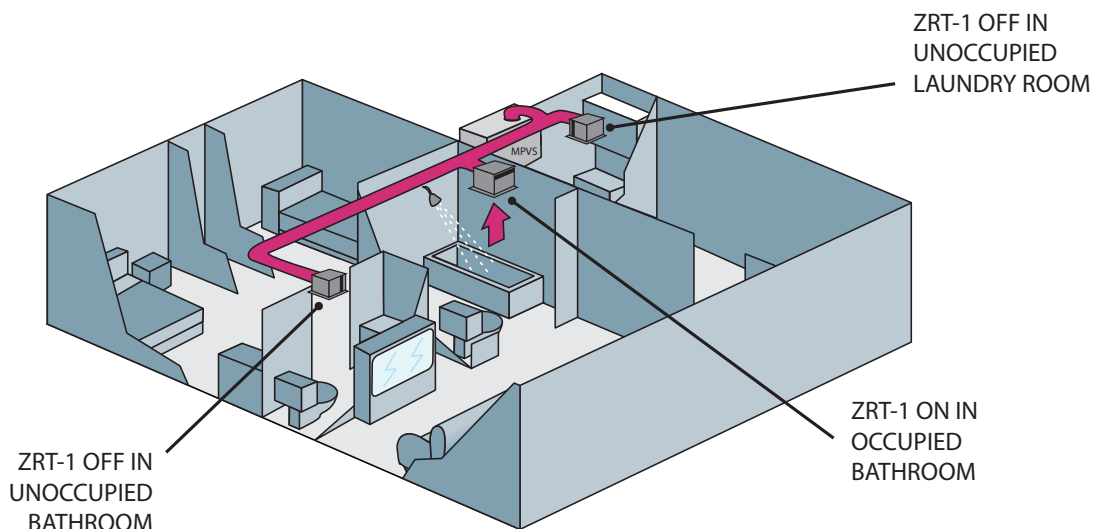

For more information, contact your Aldes sales advisor, visit aldes-na.com, call 1.800.255.7749, or find us on





Description

ALDES patented* Zone Register Terminals (ZRT®) are designed to introduce flexibility and dynamic control to central ventilation systems. Used in residential applications, the ZRT® zonally regulates ventilation where it is required without the need for individual fans. Each ZRT® is a combination grille, register box, and control damper.

To ensure the proper operation of the damper assembly, do not exceed 1.0 in. w.g. of differential pressure across the damper door. ZRT® 6" supply models require a minimum flow constant airflow regulator.

By replacing static grilles in large central systems, the ZRT-1 model provides on-off control for on-demand ventilation. This allows central fan downsizing and promotes energy savings by minimizing necessary fan horsepower and ventilation-induced heat and cooling loads on the home.

The ZRT-2 model can be used for combination low-flow indoor air quality ventilation and on-demand high-flow spot ventilation using the same central fan system. This is achieved by integrating a minimum constant airflow regulator directly into the damper sub-assembly. With the damper completely closed, the constant airflow regulator will allow steady, low-continuous ventilation during fan operation. When other terminals are opened for on-demand control of spot ventilation, the closed ZRT-2 will maintain the set low-continuous rate through the constant airflow regulator minimum flow control. By opening the ZRT-2's control damper, the low-flow regulator is removed from the air stream, allowing unrestricted maximum-boost ventilation.

Airflow rate can be set or adjusted by rotating the dial from either side. The airflow indicator will move to show the selected CFM. The airflow label has multiple defined setpoints, but the unique adjustment mechanism of the CAR3 allows for infinite adjustability between the minimum and maximum limits.

The ZRT® can activate fans used in central ventilation systems. Through the use of an integral damper end-switch, the ZRT® can trigger the remote fan to start. This provides the distinct advantage of allowing the fan to only ventilate specific spaces when called upon, without the need for separate fans in each space. This is especially important in residential bath applications using popular in-line and multi-port fans, where low noise and a single exterior vent penetration are desired.

*U.S. Pat. No. 7,766,734

ZRT-R® ZONE REGISTER TERMINAL

AIRFLOW & ZONE CONTROL **IOM**



READ AND SAVE THESE INSTRUCTIONS

ZRT-1 MODEL

ZRT-2 MODEL

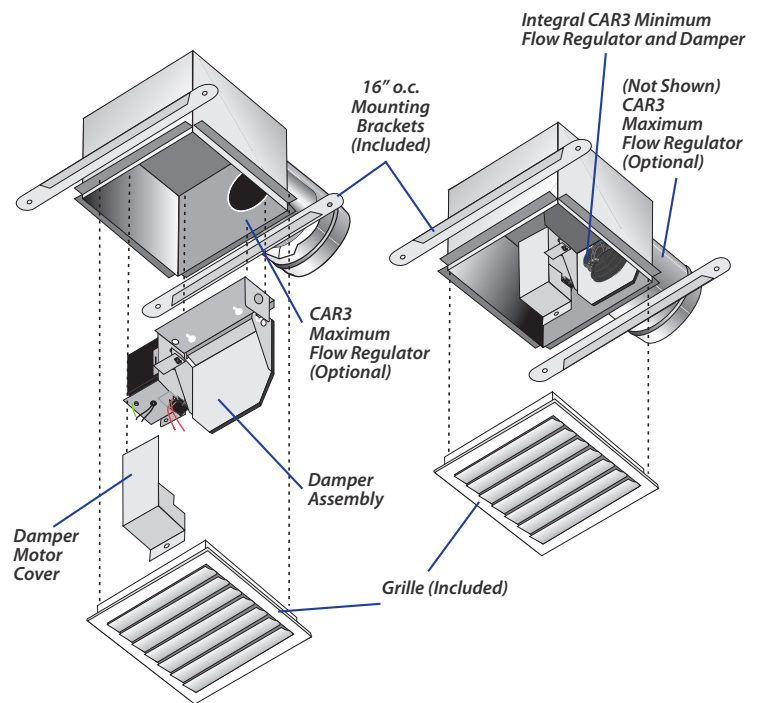

Mounting

The ZRT® is available with mounting brackets to accommodate new or existing construction. Spanner brackets that allow mounting to joists up to 16" on center are provided and should be secured using the screws provided (See Figure 1). Install additional blocking or use a single joist bracket if spacing is greater than 16" on center.

Wiring

The ZRT® is available with 24 VAC or 120 VAC actuator motors. 120 VAC wiring options are shown in Figures 2-4, and 24 VAC wiring options using the Zone Terminal Fan Control Center (Model ZTC) are shown in Figures 5 and 6.

Warning

TO REDUCE THE RISK OF FIRE, ELECTRIC SHOCK, OR INJURY TO PERSONS, OBSERVE THE FOLLOWING:

1. Use this unit only in the manner intended by the manufacturer. If you have any questions, contact the manufacturer.
2. Before servicing or cleaning the unit, switch power off at service panel and lock service panel to prevent power from being switched on accidentally. When the service disconnecting means cannot be locked, securely fasten a prominent warning device, such as a tag, to the service panel.
3. To reduce the risk of fire and electric shock, the integral damper end switch should only be used to switch ventilation equipment rated Maximum 10A, 1/2 HP.
4. Sufficient air is needed for proper combustion and exhausting of gases through the flue (chimney) of fuel-burning equipment to prevent backdrafting. Follow the heating equipment manufacturer's guidelines and safety standards, such as those published by the National Fire Protection Association (NFPA), and the American Society of Heating, Refrigerating and Air-Conditioning Engineers (ASHRAE), and the local code authorities.
5. In addition to the following manufacturer's instructions, it is necessary to comply with federal, state, and local government codes. Your purchase of this ALDES ventilation system represents an investment in the health and comfort of the occupants, as well as an investment in the protection of the building from the damaging effects of excessive indoor humidity.
6. Installation work and electrical wiring must be done by qualified person(s) in accordance with all applicable codes and standards, including fire-rated construction.
7. When cutting or drilling into wall or ceiling, do not damage electrical wiring and hidden utilities.

Caution

1. For general ventilating use only. Do not use to exhaust hazardous or explosive materials and vapors.
2. Automatically operated device. To reduce the risk of injury, disconnect from power supply before servicing.
3. ZRT® is acceptable for use over a tub or shower when installed in a GFCI-protected circuit. If wired directly to the fan or ZRT®, a single Ground Fault Protector on the 120 VAC common power supply must be used to protect all devices on the same circuit.

FIGURE 1 - MOUNTING

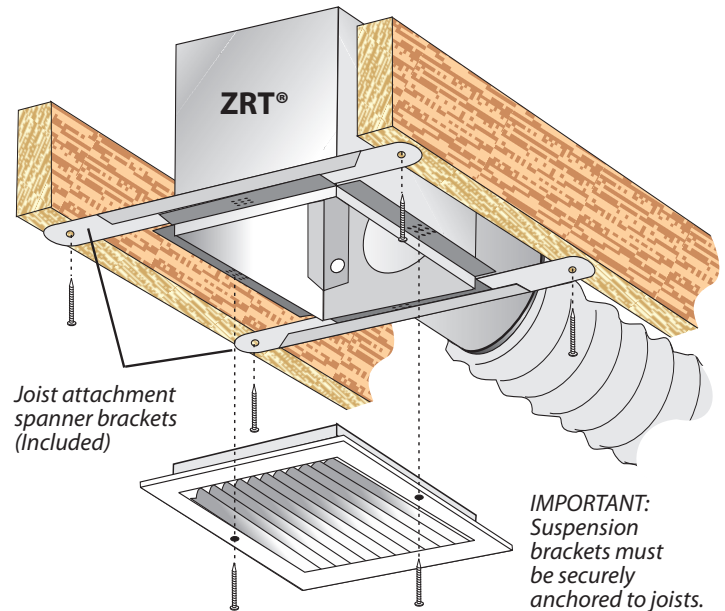

MAINTENANCE SERVICE PARTS

Damper Motor 24 VAC	85 695
Damper Motor 120 VAC	85 696
Damper Assembly 24 VAC for Models w/ 4" Duct Collar	36 134
Damper Assembly 24 VAC for Models w/ 6" Duct Collar	36 136
Damper Assembly 120 VAC for Models w/ 4" Duct Collar	36 135
Damper Assembly 120 VAC for Models w/ 6" Duct Collar	36 137

Clean the grille monthly (if so equipped).

System Design

Satisfactory performance of a central ventilation system requires:

- Proper integration of all the components, compatible grilles, and wall/roof caps;
- Proper duct design for friction losses;
- Consideration of acoustic and vibration properties of the fan and its mounting;
- Acoustic properties of the grilles;
- Consideration of the mode of operation, whether continuous or automatically controlled by dehumidistat, timer, or occupancy sensor;
- Installation in a heated or unheated space, with consideration for the potential of condensation in the ducting or fan housing.

Inspect the carton upon receipt to ensure the terminal has not been damaged in transit. If damaged, it is the responsibility of the recipient to file a damage claim with the carrier. ALDES is not responsible for damage incurred during shipment.

Handle the unit with care to prevent damage to the housing and other components. Store the unit indoors if possible. If outdoor storage is required, protection against moisture and dirt is necessary.

FIGURE 2

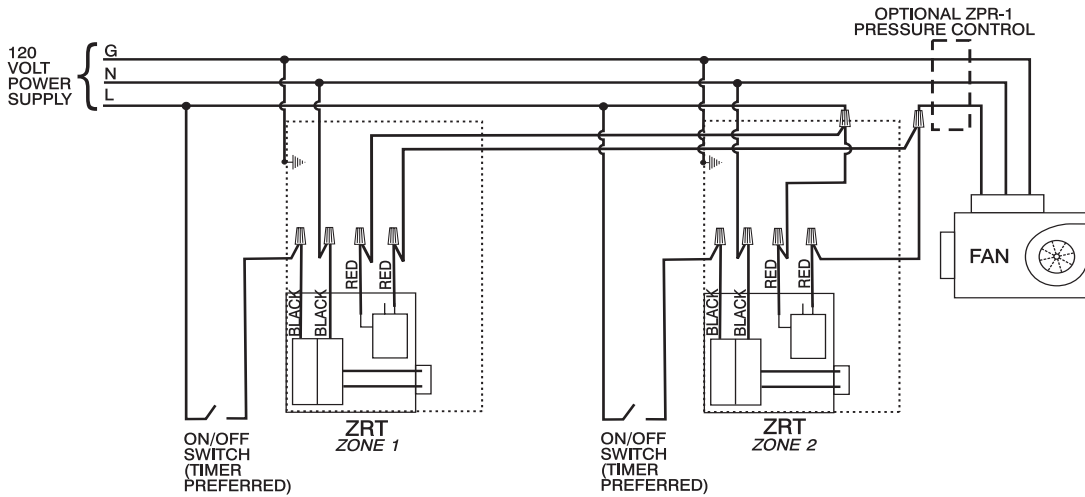

Intermittent fan operation using 120 VAC power supply to ZRT-1 terminals. SPST convenience switches, such as manually operated switches, mechanical timers, or dehumidistats, may be used to control each ZRT and fan in this configuration.

FIGURE 3

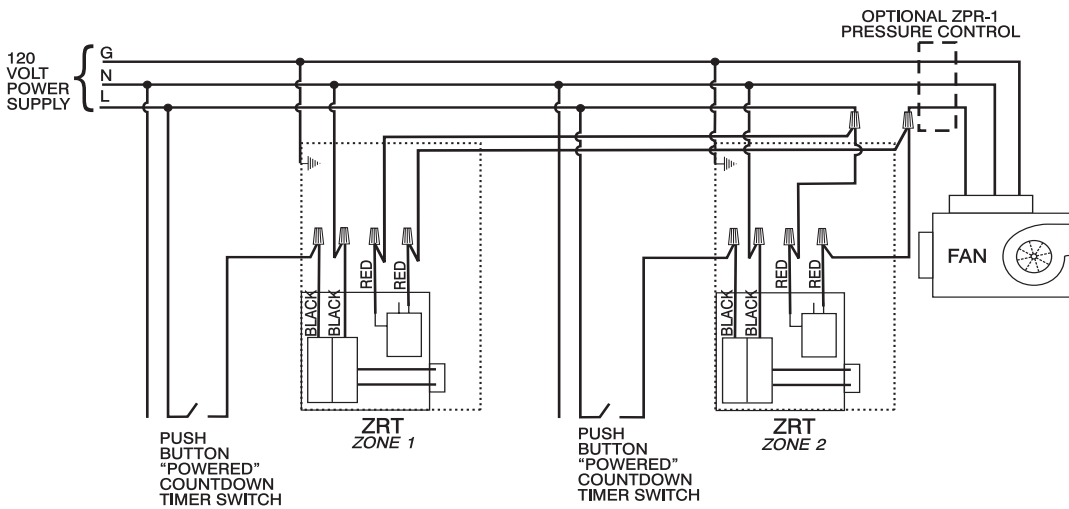

Intermittent fan operation using 120 VAC power supply to ZRT-1 terminals. SPST convenience switches, such as push-button timers or motion sensors, may be used to control each ZRT and fan in this configuration.

FIGURE 4

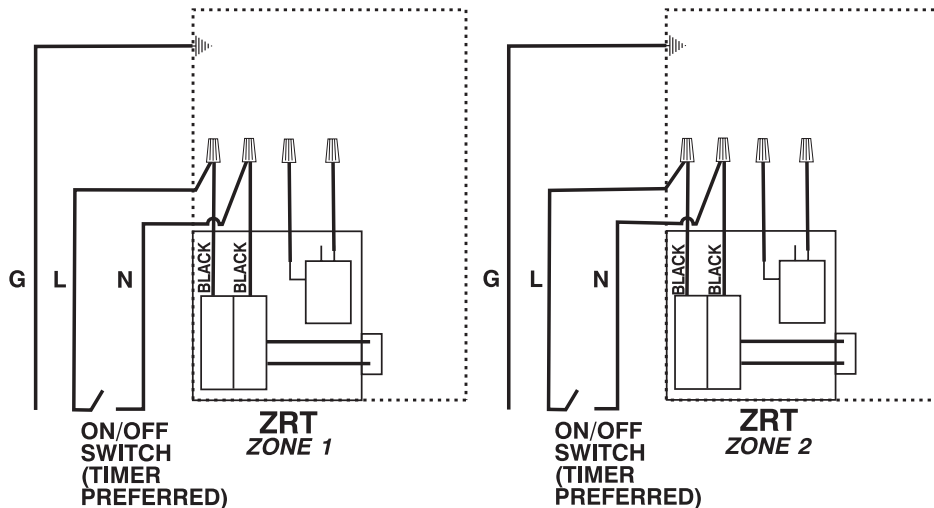

Continuous fan operation using 120 VAC power supply to ZRT-2 terminals. The fan and ZRT terminals may be wired independently.

FIGURE 5

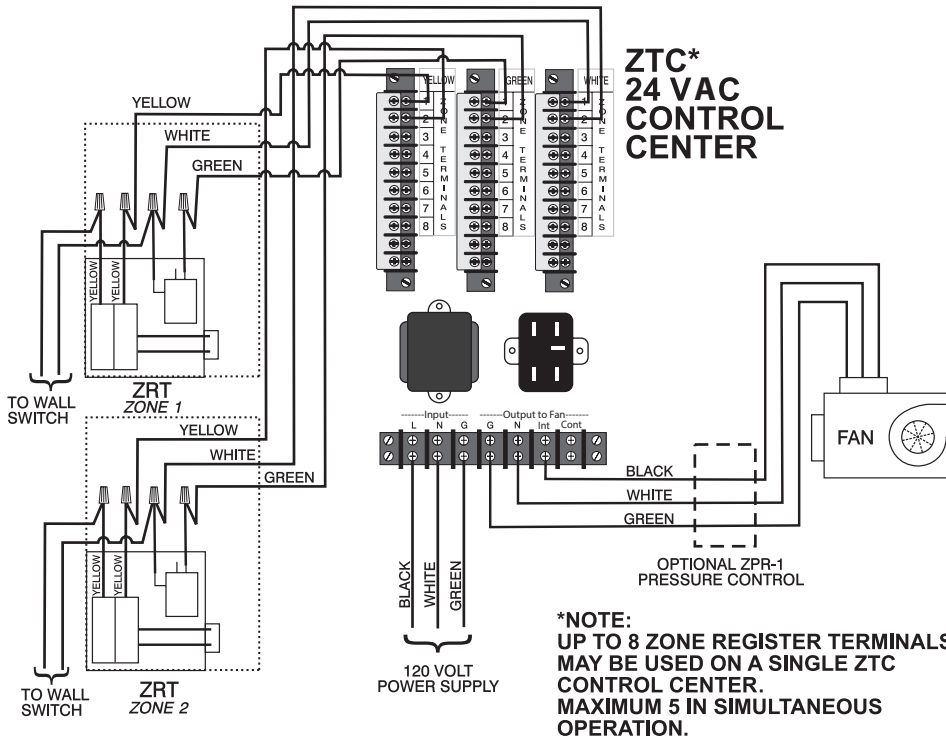

Intermittent fan operation using 24 VAC ZTC Zone Terminal Control Center and ZRT-1 terminals. SPST convenience switches, such as manually operated, mechanical timers, or dehumidistats, may be used to control each ZRT and fan in this configuration. The fan is controlled by the ZTC.

FIGURE 6

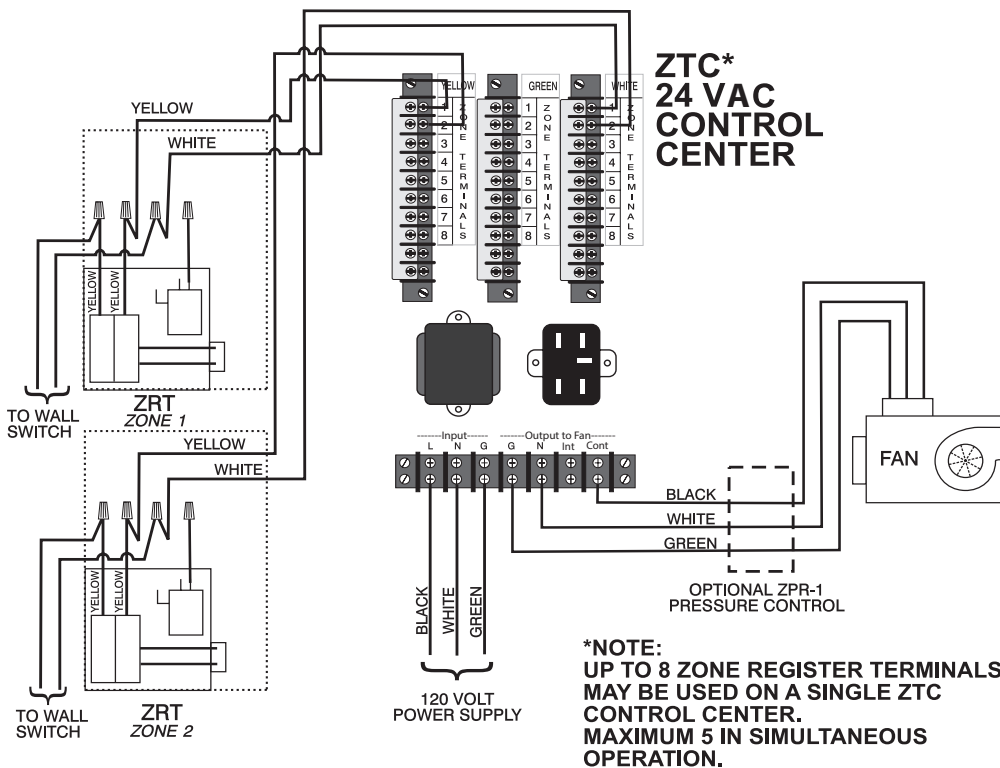

Continuous fan operation using 24 VAC ZTC Zone Terminal Control Center and ZRT-2 terminals. SPST convenience switches, such as manually operated, mechanical timers, or dehumidistats, may be used to control each ZRT in this configuration. The fan may be wired independently or to the ZTC.

For more information, contact your Aldes sales advisor, visit aldes-na.com, call 1.800.255.7749, or find us on





MPVS150 & MPVS200

MULTI-PORT EXHAUST VENTILATORS

VENTERGY® SERIES FANS

IOM

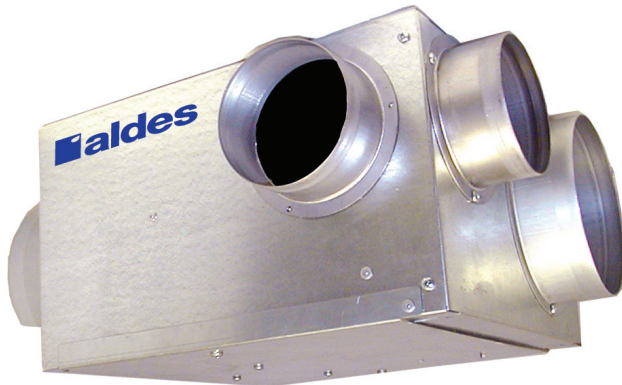

READ AND SAVE THESE INSTRUCTIONS

Product Description

Ventergy® Series Multi-Port Ventilators (MPVS) are highly versatile, continuous-duty rated fan units for residential and light commercial applications. They meet ENERGY STAR efficiency criteria for low energy consumption. The most popular use for the fan is central exhaust ventilation of bathrooms, kitchens, laundry rooms, and other rooms where humidity is a controlling factor since the fan has a single exhaust discharge duct directly to the outdoors.

The principal advantage of the MPVS is the elimination of standard noisy bath fans, with the benefits of quiet operation and reduced penetrations to the exterior of the building. With the increasingly tight construction of energy-efficient buildings, there is a growing need for mechanical ventilation for indoor air quality. These fans are designed to serve this purpose by providing effective bathroom ventilation with the ability to run intermittently or continuously. The quiet, energy-efficient, permanent-split-capacitor type of external-rotor motor has permanently sealed bearings that provide many years of maintenance-free performance.

Construction

The MPVS is constructed of heavy-gauge galvanized steel to prevent corrosion caused by moisture. The cabinet is internally lined with acoustic, closed-cell foam insulation that acts as a vapor barrier. This allows installation directly above living spaces or in unheated plenum spaces without concern for noise or condensation.

Controls

The fans can be operated manually or automatically by a programmable timer or dehumidistat. They may also be operated in conjunction with a variable speed control.

Ducting the Fan

The ducting from this fan to the outside of the building has a strong effect on the airflow, noise and energy use of the fan. Use the shortest, straightest duct routing possible for best performance, and avoid installing the fan with smaller ducts than recommended. Insulation around the ducts can reduce energy loss and inhibit mold growth. Fans installed with existing ducts may not achieve their rated airflow.

Use ductwork of a diameter that is the same as or greater than the diameter of the duct connectors on the fan.

Fan and Motor

The fan motor is an energy-efficient, permanent-split-capacitor type of external-rotor design. Totally sealed to protect against moisture and contaminants, it is approved for removing steam and moisture from kitchen and bath areas. The motor incorporates permanently lubricated and sealed bearings and automatic-reset thermal-overload protection. It is designed and certified for continuous duty or intermittent operation.

The fan uses a backward-inclined impeller design that prevents dust from collecting on the blades. Each fan is statically and dynamically balanced in the factory to eliminate vibration and ensure quiet operation. The entire motor and fan assembly is mounted on a drop-down hinged access panel for simple service and inspection, and it can be removed from the fan without disassembling the duct connections.

Locating and Installing

The compact dimensions and versatile mounting options permit installation above drop ceilings, between ceiling joists, or within a small soffit location. They can be installed horizontally or vertically.

Accessories

Accessory kits are available to facilitate installation and enhance operation. Accessories kits are sold separately. Please visit aldes-na.com, or contact your local Aldes distributor for details.

Performance

Fan airflow and energy performance shall be tested in accordance with HVI procedures.



Dimensions & Performance

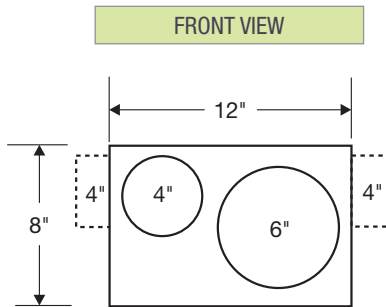
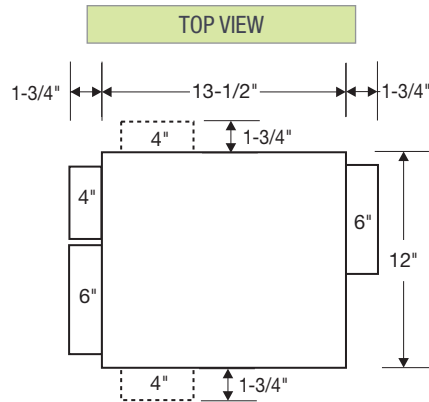

NOTE: Location(s) of field-installed 4" side-tap collar(s) shown as dashed lines.

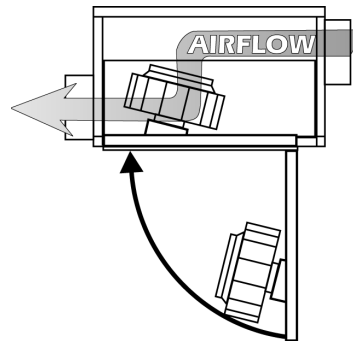

Drop-down hinged access panel for simple service and inspection

ELECTRICAL AND AIRFLOW PERFORMANCE*											
Model	Watts at 0.2" Ps	CFM vs. Static Pressure									ENERGY STAR Certified
		0"	0.2"	0.4"	0.6"	0.8"	1.0"	1.2"	1.4"	1.6"	
MPVS150	39.9	212	170	133	101	71	49	17	--	--	✓
MPVS200	62.5	287	250	227	198	168	136	100	65	24	✓

*Certified airflow rating at 0.2" w.g. is derated from actual test results per HVI Certification procedure 920. The HVI Certified Rate for MPVS150 = 170 CFM, MPVS200 = 250 CFM.

ELECTRICAL DATA
 MPVS150: 115 V, 60 Hz, 41 W, 0.34 A, 2200 RPM
 MPVS200: 115 V, 60 Hz, 59 W, 0.53 A, 2960 RPM
Above ratings are intended for sizing electrical wiring only. Actual consumption will be lower.

AIRFLOWS AND DUCT LENGTHS*

AIRFLOW CFM	INTAKE DUCT TO FAN Recommended Max. Duct Length from Grille to Fan (ft.)			
	4" SMOOTH	4" FLEXIBLE	6" SMOOTH	6" FLEXIBLE
50	50	30	400	250
60	40	20	280	175
80	--	--	170	95
100	--	--	110	70
TOTAL EXHAUST RATE CFM	FAN DISCHARGE DUCT Assumes low-pressure drop-vent cap		FOR EACH ELBOW DEDUCT	
	6" SMOOTH	4" FLEXIBLE		
175	20 ft.	10 ft.	4" Diameter = 4 ft. 6" Diameter = 7 ft.	
200	15 ft.	8 ft.		
225	13 ft.	7 ft.		

*This table should only be used as a general guide. Actual duct length allowances may be longer on some models. Contact the factory for assistance.
 NOTE: 3" Ducting may be substituted to permit installation in partition walls. Smaller diameter ducting has increased resistance to airflow. For each foot of 3" ducting substituted for 4" diameter duct, reduce the allowable duct length by 3 feet. If duct runs longer than permitted in the table above are required, use smooth ducting and/or increase the diameter.

REFERENCE RDF INSTALLATION SUPPLEMENT FOR ADDITIONAL INSTRUCTIONS AND WARRANTY INFORMATION.

MPVS150/MPVS200 SCHEMATIC

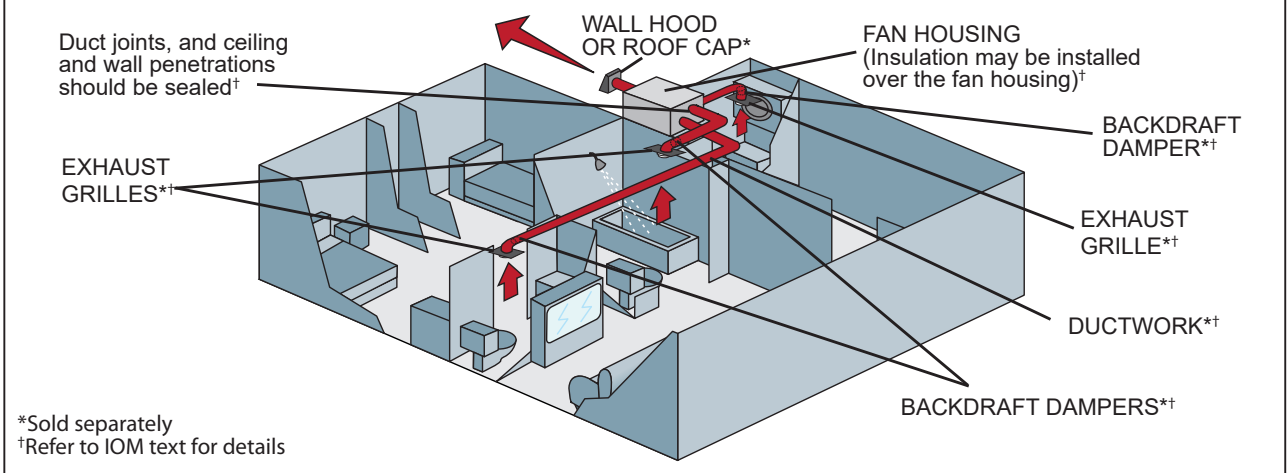

MOUNTING BRACKET LOCATIONS

Small dimples or "scratches" are machined on the fan housing to aid in using the #8-3/4" self-tapping screws (provided) for mounting bracket installation. The locations are represented in the diagram below. To prevent potential damage to internal parts, DO NOT use screws or washers other than those provided. Use four (4) screws and washers for each bracket.

Additional 4" collar(s) may be provided for field installation, depending on your specific model. Collars are installed on the side(s) of the base MPVS at the knock-out locations as indicated below.

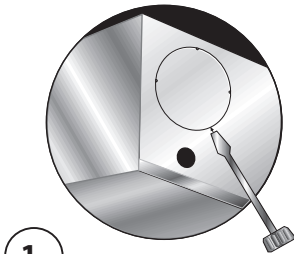
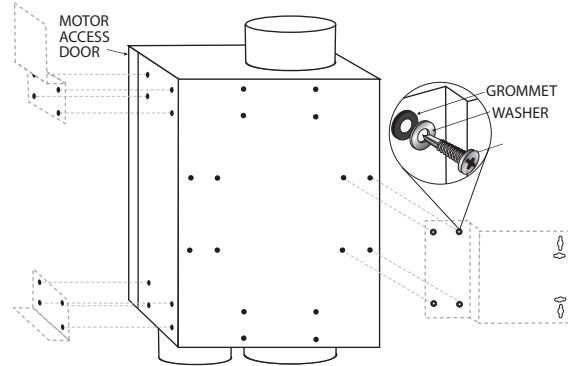

1.

(1) Remove the metal knock-out using a slot-type screw driver or similar tool. Make one firm hit to holding tabs. The liner applied to the inside of the knock-out should break away from the fan liner, but additional trimming with a sharp knife may also be required (pull out from the inside of box).

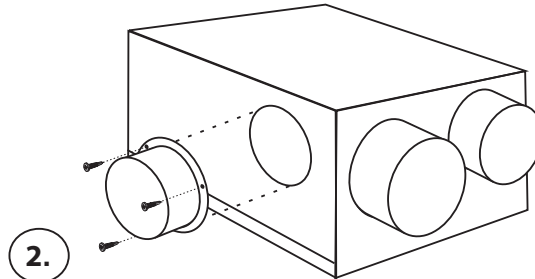

2.

(2) Attach the collar(s) provided using #8-1/2" screws (also provided).



RDF INSTALLATION SUPPLEMENT RECTANGULAR DUCT FAN

VENTERGY® SERIES FANS

IOM

READ AND SAVE THESE INSTRUCTIONS

For the following base models:

RDF 8-8IP, RDF 8-8MAX, RDF 12-8IP, RDF 12-8

(See supplemental instructions for derived models with duct adapters, manifolds, etc., as appropriate for your particular model.)

WARRANTY
3 YEARS

Installation

Upon receipt, inspect the carton to ensure the fan has not been damaged in transit. If damaged, it is the responsibility of the recipient to file a damage claim with the carrier. ALDES North America is not responsible for damage incurred during shipment.

Handle the unit with care to prevent damage to the housing and other components. Store the unit indoors if possible. If outdoor storage is required, protection against moisture and dirt is necessary.

Unpack the unit, taking care to look for any loose components among the packing material. Make certain that the fan housing and the blower are free of any loose packing material or small parts. If not removed before startup, damage and injury may result from solid objects discharged by the blower. Inspect for damaged, loose, or missing parts.

A location should be chosen that will minimize the length of duct runs and the number of elbows that are required. If more than four (4) 90° elbows are required, 45° elbows should be used. If insulated flexible duct is used, the inner sleeve should be fully expanded over the entire duct run. Any turns that are necessary in the flexible duct run should be made as gradually as possible. Choose roof and/or wall caps that are of a more open, less restrictive design. The perimeter of all ceiling and wall penetrations for ductwork and grille(s) should be properly sealed with caulk or a similar material to ensure that there is not an air leakage path between the device and the wall and/or ceiling.

Install the unit in its final location. The fan may be installed in a mechanical room, crawl space, or attic. It is designed to be placed on a flat surface, against a wall or trusses, or suspended from above. If set on a flat surface, vibration-isolation pads are recommended. Mounting brackets with rubber grommets are supplied to permit installation against a vertical surface or from the ceiling. Alternately, the fan may be suspended using threaded rods or chains. At least 12 inches clearance from the access panel is needed to permit servicing the motor. Loose fill or batt insulation can be installed over the unit if the unit's access doors can still be opened.

Mounting

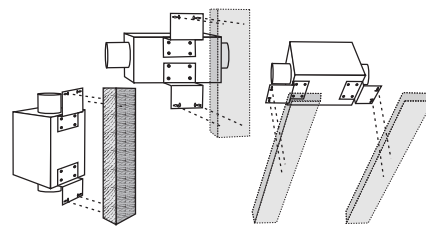

**FANS MAY BE
MOUNTED VERTICALLY
OR HORIZONTALLY**

(Differences in bracket type and configuration may exist on some derived models. Refer to supplement where appropriate). Orient the fan so that the access door can be opened for service.

Tools Required:

Power screwdriver with No. 2 Phillips bit.

Mounting brackets are supplied with the fan. The brackets may be mounted to the fan using the self-drilling screws and rubber grommets provided, at the locations indicated by dimple marks on the side and bottom panels of the fan. Pan head number 10 screws are provided to attach the mounting bracket to the building framing members. It may be necessary to add additional framing members to span wall studs. It is not recommended to use drywall anchors to support the fan. If installed against a concrete or masonry wall, concrete anchors are recommended. The rubber grommets provide vibration isolation. The brackets should be attached to the fan first. Then install the wood screws at the keyhole locations and install the fan.

The fan may also be mounted on a foam rubber pad on a flat surface, such as an attic floor.

Cold Climate Precautions

If installed in an unheated space in cold climates, there is a possibility of condensation forming in the fan housing or ducting components. A backdraft damper installed at each grille is an effective way to reduce the potential for condensation when the fan is cycled on and off. Insulated ducting must be used where exposed to cold attic or crawl space temperatures to avoid condensation in the ducting. Condensation can also be avoided by continuous operation of the fan.



Caution

FOR GENERAL VENTILATING USE ONLY. DO NOT USE TO EXHAUST HAZARDOUS OR EXPLOSIVE MATERIALS AND VAPORS.

Warning

TO REDUCE THE RISK OF FIRE, ELECTRIC SHOCK, OR INJURY TO PERSONS, OBSERVE THE FOLLOWING:

1. Use this unit only in the manner intended by the manufacturer. If you have any questions, contact the manufacturer.
2. Before servicing or cleaning the unit, switch power off at service panel and lock service panel to prevent power from being switched on accidentally. When the service disconnecting means cannot be locked, securely fasten a prominent warning device, such as a tag, to the service panel.

In addition to the following manufacturer's instructions, it is necessary to comply with federal, state, and local government codes. Your purchase of this ALDES North America system represents an investment in the health and comfort of occupants, as well as an investment in the protection of the building from the damaging effects of excessive indoor humidity.

This model of centrifugal fan is designed for multiple purposes. It may be used as an in-line rectangular duct fan (Model RDF) or a manifolded, multi-port fan for multiple exhaust or supply points. It may be installed in a remote location such as an attic space, mechanical room, above a drop ceiling, in a closet or in a laundry room, to provide quiet exhaust of stale, humid, or otherwise polluted air from bathrooms, kitchens, laundry rooms, or storage rooms via exhaust grilles and ducting to the centrally located fan, which is ducted to the outdoors. With small return grilles in bedrooms and other areas, and one duct connection to the outdoors, such as the BVS models, it may also be used as a supply ventilator or recirculating central ventilator for the introduction of outdoor air, raising the temperature of the fresh air by mixing with recirculated indoor air. When used with adjustable balancing grilles or ALDES Constant Airflow Regulators (CAR) and compatible roof/wall caps, ducting, etc., the fan is the heart of a complete pre-engineered ventilation system.

System Design

Satisfactory performance of a central ventilation system requires the proper integration of all the components:

- Fan selection for airflow, pressure and acoustic properties, vibration characteristics and mounting method, and mode of operation (continuous, manually or automatically controlled)
- Proper duct design for friction losses, with compatible supply or exhaust grilles (airflow and acoustic properties of the supply/exhaust grilles), and compatible wall/roof caps
- Method of balancing airflows of multi-point ventilation systems
- Consideration for potential condensation in the ducting or fan housing (installation in an unheated space)

Duct Connections

Ducting may be flexible or rigid, depending on local codes. If permitted by code, insulated flexible ducting is recommended. To limit fan noise, at least 8 feet of insulated flexible duct shall be installed between the fan and grille(s). All flexible duct connections shall be secured with clamps or wire ties and sealed with mastic or code-approved duct tape. All rigid ducts are to be sealed on both ends and along the longitudinal seams with mastic or code-approved duct tape.

Ducting should conform to NFPA 90A and meet the requirements of UL as a Class 0 or Class 1 duct to specification UL 181, Standard for Factory-Made Air Ducts and Duct Connectors.

Installation Warning

TO REDUCE THE RISK OF FIRE, ELECTRIC SHOCK, OR INJURY TO PERSONS, OBSERVE THE FOLLOWING:

1. Installation work and electrical wiring must be done by qualified person(s) in accordance with all applicable codes and standards, including fire-rated construction.
2. Sufficient air is needed for proper combustion and exhausting of gases through the flue (chimney) of fuel-burning equipment to prevent backdrafting. Follow the heating equipment manufacturer's guidelines and safety standards such as those published by the National Fire Protection Association (NFPA), the American Society for Heating, Refrigeration and Air Conditioning Engineers (ASHRAE), and the local code authorities.
3. When cutting or drilling into wall or ceiling, do not damage electrical wiring and other hidden utilities.
4. When used as exhaust fans, ducted fans must always be vented to the outdoors.
5. If this unit is to be installed over a tub or shower, it must be marked as appropriate for the application and be connected to a GFCI- (Ground Fault Circuit Interrupter) protected branch circuit.
6. NEVER place a switch where it can be reached from a tub or shower.

MAINTENANCE

MONTHLY: Inspect and clean the exhaust grilles and filters, if so equipped.

ANNUALLY: To ensure the maximum efficiency of the fan unit, it is recommended to clean the inside of the fan box as well as the blower wheel.

Electrical Data

Provide disconnect switch in vicinity of fan to permit servicing fan in accordance with NEC and local codes.

Depending on the desired mode of operation, switches may be simple on-off switches, motor speed controls, timer switches, time delay, time-of-day cycle timers, dehumidistats, occupancy sensing controls, controllers, etc., provided they are rated for the motor duty and meet the nameplate electrical ratings of the motor. (Additional application wiring diagrams illustrating a variety of controls for use with RDF fans are available by calling the factory at 1-800-255-7749.)

Base Model	Volts	Max Amps	Max Watts	RPM
RDF 8-8IP	115	0.19	20	2324
RDF 8-8MAX	115	0.29	34	3135
RDF 12-8IP	115	0.34	41	2200
RDF 12-8	115	0.53	59	2960

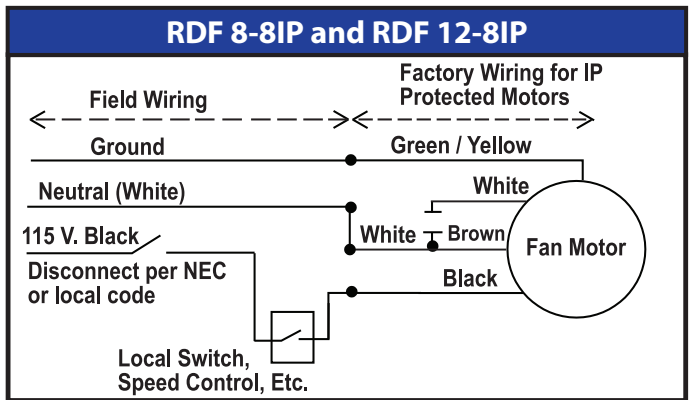
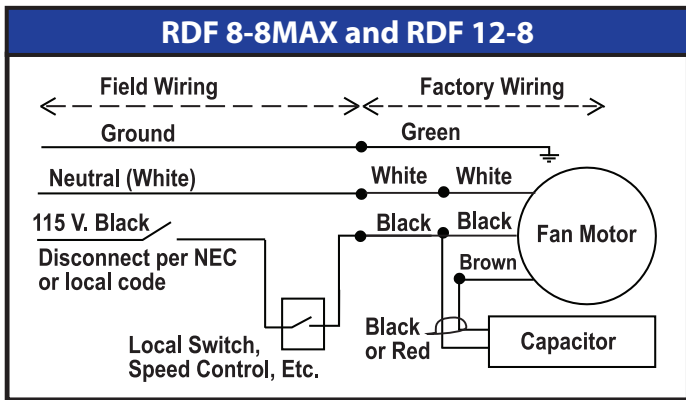

Disclaimer

IT IS THE RESPONSIBILITY OF THE CONTRACTOR/INSTALLER TO DETERMINE THE SUITABILITY OF THIS EQUIPMENT WITH RESPECT TO THE POTENTIAL FOR BACKDRAFTING NATURALLY VENTED FLUE DEVICES AND/OR AFFECTING RADON ENTRY.

Impact of Exhaust Fans

In especially tight homes heated with naturally vented appliances, such as gas, oil or wood-fired furnaces, boilers, stoves or fireplaces, the exhaust system may produce sufficient negative pressure indoors to induce the backdrafting of flue gases. This is a common, though intermittent, occurrence, with conventional exhaust systems, such as vented kitchen range hoods, clothes dryers, bath fans, etc. In the case of continuous exhaust, though often at lower flow rates, the potential for backdrafting the flue of these appliances does exist and represents a dangerous situation.

The International Fuel Gas Code, Appendix D provides a Recommended Procedure for Safety Inspection of an Existing Appliance Installation. This procedure should be followed to determine the presence of adequate combustion air while all exhaust fans are operating at maximum speed and all doors and windows are closed.

In the event that backdrafting occurs, steps must be taken to provide sufficient combustion air to the furnace or boiler, following the guidelines of the National Fuel Gas Code and all state and local codes.

Caution

AUTOMATICALLY OPERATED DEVICE. TO REDUCE RISK OF INJURY, DISCONNECT FROM THE POWER SUPPLY BEFORE SERVICING.

Disassembly

Turn off all power to the unit. The blower may be inspected and cleaned by removing the two screws from the hinged access panel. The blower assembly can now be swung open for cleaning the wheel.

For installations in which the fan is connected to a range hood, or if an exhaust grille connected to the fan is located near the cooking surface (as shown below), be sure to observe the following safety warnings:

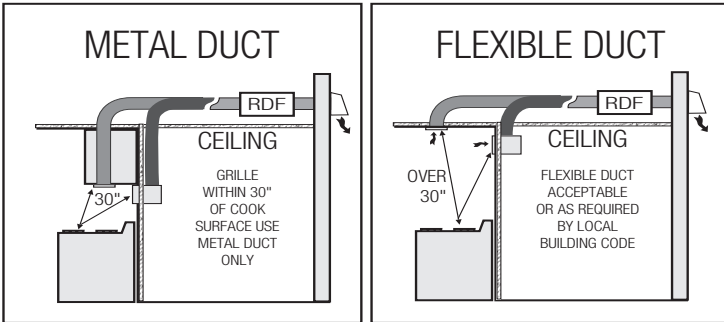

Warning

TO REDUCE THE RISK OF FIRE, USE ONLY GALVANIZED STEEL DUCTWORK WHEN REQUIRED TO USE METAL DUCT.

NOTE: If only rigid ducting is allowed, a metal sound attenuator shall be installed between the fan and the range hood.

NOTE: If the fan is not connected to a range hood or a grille in the vicinity of the cooking surface, other approved ducting may be used as described in the "Duct Connections" section of basic instructions.

Range Hood/Cooking Surface Warning

TO REDUCE THE RISK OF INJURY TO PERSONS IN THE EVENT OF A RANGE-TOP GREASE FIRE, OBSERVE THE FOLLOWING:

1. Never leave surface units unattended at high settings. Boilovers cause smoking and greasy spillovers that may ignite. Heat oils slowly on low or medium settings.
2. Always turn range hood ON when cooking at high heat or flambeing food.
3. Clean ventilating fans frequently. Grease should not be allowed to accumulate on fan or filter. Use proper pan size. Always use cookware appropriate for the size of the surface element.
4. SMOTHER FLAMES with a close-fitting lid, cookie sheet, or metal tray, then turn off the burner. BE CAREFUL TO PREVENT BURNS. If the flames do not go out immediately, EVACUATE AND CALL THE FIRE DEPARTMENT.
5. NEVER PICK UP A FLAMING PAN - You may be burned.
6. DO NOT USE WATER, including wet dishcloths or towels, because a violent steam explosion could result.
7. Use an extinguisher ONLY if:
 1. You know you have a Class ABC extinguisher, and you already know how to operate it.
 2. The fire is small and contained in the area where it started.
 3. The fire department is being called.
 4. You can fight the fire with your back to an exit.

Based on "Kitchen Fire Safety Tips" published by NFPA.

Mechanical Supply Fans

Mechanical supply of outdoor air tends to reduce the potential and frequency of backdrafting by reducing the contributing negative pressures; however, due to a multitude of factors, including the wide range of exhausting appliances that may be present, the effects of wind and building shape, the presence of multiple chimneys, building leakage, and the use of operable windows, no one can assure elimination of backdraft conditions so long as atmospherically vented combustion equipment is present in the home.

ALDES North America accepts no liability for backdraft conditions resulting from negative pressures. Nor does ALDES North America make representation that blending supply ventilators (BVS) are adequate to prevent such occurrences.

REPLACEMENT PARTS LIST (BASE MODELS)				
Model	Motor P/N	Impeller Dimensions (mm)	Capacitor	
			P/N	Cap
RDF 8-8IP*	86 561	133 x 42	86 172	4uF
RDF 8-8 MAX	86 561	133 x 45	86 172	4uF
RDF 12-8IP*	86 562	180 x 35	86 179	10uF
RDF 12-8	86 562	180 x 35	86 170	5uF

*Designates Impedance Protection with alternate wiring of capacitor across auxiliary winding of motor.



3 Year Warranty: This Warranty Supersedes All Prior Warranties

DURING THE FIRST 30 DAYS:

ALDES will repair or replace any product that has a factory defect in workmanship or material. Product(s) may be returned to point of purchase or the ALDES factory, with Bill of Sale, for an immediate replacement.

DURING THE FIRST 3 YEARS:

(Excluding the 30-day period above)
ALDES will repair or replace any product that has a factory defect in workmanship or material. Product(s) must be returned to the ALDES factory, with Bill of Sale and identified with an RMA number, within 3 years of purchase. The warrantee assumes all costs to and from the factory.

WARRANTY DOES NOT APPLY TO THE FOLLOWING:

1. Damages from shipping, either concealed or visible. Claim must be filed with the carrier.
2. Damages resulting from improper wiring or installation.
3. Damages or failure caused by Acts of God, or resulting from improper consumer procedures, such as:
 - Improper maintenance
 - Misuse, abuse, abnormal use, or accident
 - Incorrect electrical voltage or current
 - Removal or alterations made on the ALDES label, control number, or date of manufacture.
4. Any other warranty, expressed, written, or implied, and to any consequential or incidental damages, loss of property, revenues, or profit, or costs of removal, installation, or reinstallation, for any breach of warranty.

WARRANTY VALIDATION

The end user must keep a copy of the Bill of Sale to verify purchase date. Valid proof of the date of installation may also serve as a verification of commencement of warranty period.

ALDES RETURN POLICY

Claims for damages or order shortages must be reported within 10 days of receipt of product(s). For any product(s) received damaged by the forwarding agent, the following instructions MUST BE followed:

1. For product(s) delivered by UPS:
 - Concealed Damages: Keep all cartons; call UPS for an inspection and notify ALDES immediately.
 - Visible Damages: Save all cartons and file a complaint directly with UPS.
2. For product(s) delivered by Common Carrier: File damaged goods claim directly with the freight company.
3. Shortages: Only sign for the total number of pieces received and contact ALDES immediately.

FOR FACTORY RETURN

ALDES WILL NOT ACCEPT THE RETURN OF ANY SPECIAL, NON-STOCK, OBSOLETE, OR UNSALABLE PRODUCT(S). ALDES MAY, AT ITS DISCRETION, ACCEPT RETURN OF SALABLE PRODUCT(S) SUBJECT TO A 25% RESTOCKING CHARGE.

1. No product(s) will be accepted without a Return Materials Authorization (RMA) number. RMA number can be obtained by calling ALDES at 1-800-255-7749. Have the Bill of Sale or proof of date of installation available.
2. RMA must be clearly marked on outside of carton or delivery will be refused. All product(s) must be returned freight prepaid.
3. Product(s) will be repaired/replaced and shipped back to buyer; no credits will be issued.
4. Any out-of-warranty product will be evaluated and buyer will be notified of cost. Repair cost will be charged to customer. Buyer will be responsible for return freight, or product may be returned to the buyer, freight collect, without action. No credit will be issued.

LIMITATIONS OF WARRANTY AND LIABILITY

This warranty does not apply to any ALDES product or part which has failed as a result of faulty installation or abuse, incorrect electrical connections or alterations made by others, use under abnormal operating conditions, or misapplication of the product or parts. ALDES will not approve for payment any repair not made by us or our authorized agent without prior written consent. The foregoing shall constitute our sole and exclusive warranty and our sole exclusive liability, and is in lieu of any other warranties, whether written, oral, implied, or statutory. There are no warranties that extend beyond the description herein. In no event, whether as a result of breach of contract or warranty, or alleged negligence, defect, incorrect advice or other causes, shall ALDES be liable for special or consequential damages, including but not limited to, loss of profits or revenue, loss of use of equipment or any other associated equipment, cost of capital, cost of substitute equipment, facilities or services, downtime costs, or claims of customers of purchases for such damages. ALDES neither assumes nor authorizes any person to assume for it any other liability in connection with the sale of product(s) or part(s). Some jurisdictions do not allow the exclusion or limitation of incidental or consequential damages, so the above limitations and exclusions may not apply to you.

WARNING

ALDES products are designed and manufactured to provide reliable performance, but they are not guaranteed to be 100% free of defects. Even reliable products will experience occasional failures and this possibility should be recognized by the user. If these products are used in a life-support ventilation system where failure could result in loss or injury, the user should provide adequate back-up ventilation, supplementary natural ventilation, a failure alarm system, or willingly acknowledge the risk of such loss or injury.

For more information, contact your Aldes sales advisor, visit aldes-na.com, call 1.800.255.7749, or find us on



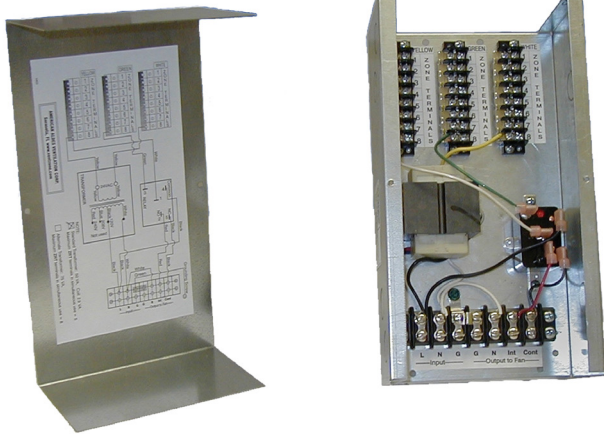

ZTC

FAN CONTROLS

ZONE TERMINAL CONTROL
(P/N 28 550)

IOM

READ AND SAVE THESE INSTRUCTIONS

Precautionary Information

THIS CONTROL MUST BE INSTALLED BY A QUALIFIED INSTALLER. All wiring must conform to local and national electrical codes and ordinances.

WARNING! DO NOT USE ON CIRCUITS EXCEEDING SPECIFIED VOLTAGE. HIGHER VOLTAGES WILL DAMAGE CONTROL AND COULD CAUSE SHOCK OR FIRE HAZARD.

CAUTION: TO REDUCE THE RISK OF FIRE AND ELECTRIC SHOCK, INSTALL THIS CONTROL ONLY WITH REMOTE EXHAUST FAN MODELS RATED MAXIMUM 8AMPS.

NOTE: If power disconnect switch is not in sight, lock it in the OFF position and tag it to prevent unexpected application of power.

Specifications

Input Ratings:

Voltage: 120VAC 60Hz
Power: 8A MAX

Mounting:

Mounts with four 1-1/4" #10 screws (provided) through holes in base. Wall anchors are provided.

Wiring:

18-gauge for low-voltage connections to ZRT terminals;
14-gauge for power and equipment connections

Wiring Connections:

ZRT: Y, G, W
Equipment: G, N, Cont or Int.
Power: L, N, G

Product Description

The Zone Terminal and Fan Control Center (ZTC) provides low-voltage control of the line-voltage circuits and can be used to control blower motors and auxiliary circuits in ventilating equipment. The ZTC can control up to (8) 24V ALDES North America patented* Zone Register Terminals (ZRT®).

Installation

CAUTION: DO NOT MOUNT DIRECTLY ON FAN, OR OTHER ELECTRICALLY POWERED EQUIPMENT. Mount only on wall or structure framing member.

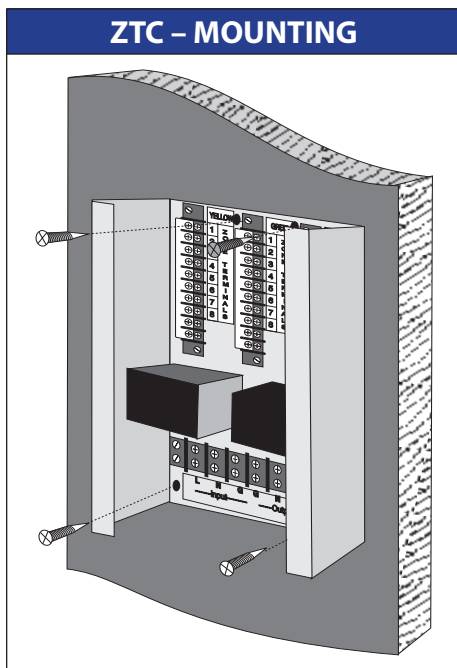

CAUTION: TO PREVENT ELECTRICAL SHOCK AND/OR EQUIPMENT DAMAGE, DISCONNECT ELECTRIC POWER TO SYSTEM AT MAIN FUSE OR CIRCUIT BREAKER BOX UNTIL INSTALLATION IS COMPLETE LABEL ALL WIRES PRIOR TO DISCONNECTION WHEN SERVICING CONTROLS. WIRING ERRORS CAN CAUSE IMPROPER AND DANGEROUS OPERATION. AFTER INSTALLATION OR REPLACEMENT, FOLLOW APPLIANCE MANUFACTURERS' RECOMMENDED INSTALLATION SERVICE INSTRUCTIONS TO ENSURE PROPER OPERATION.

*U.S. Pat. No. 7,766,734

Wiring

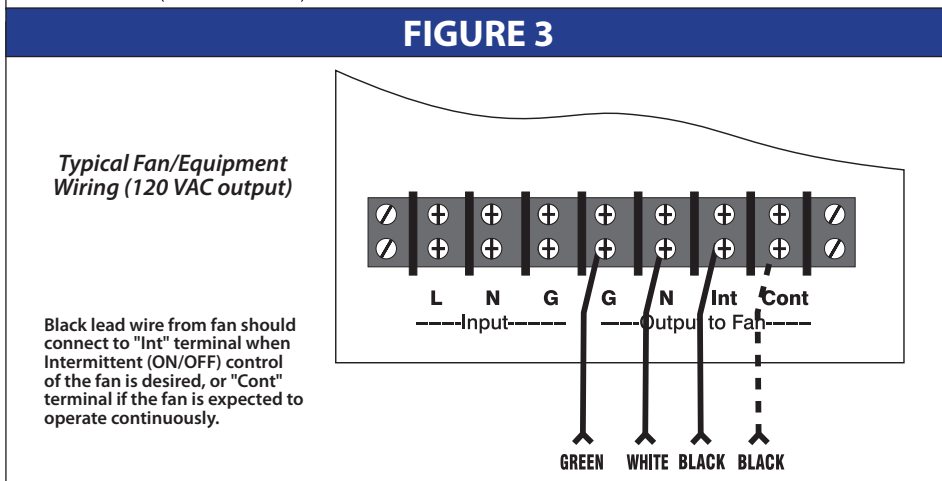
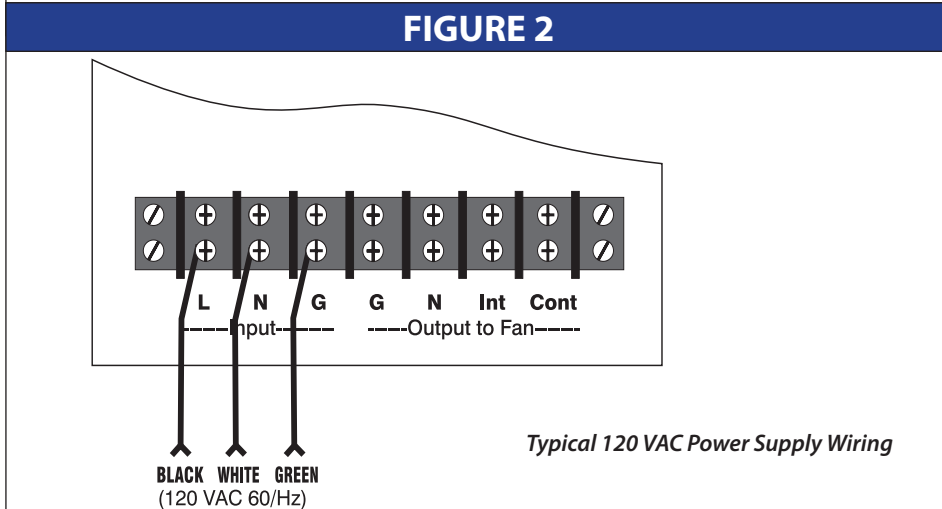
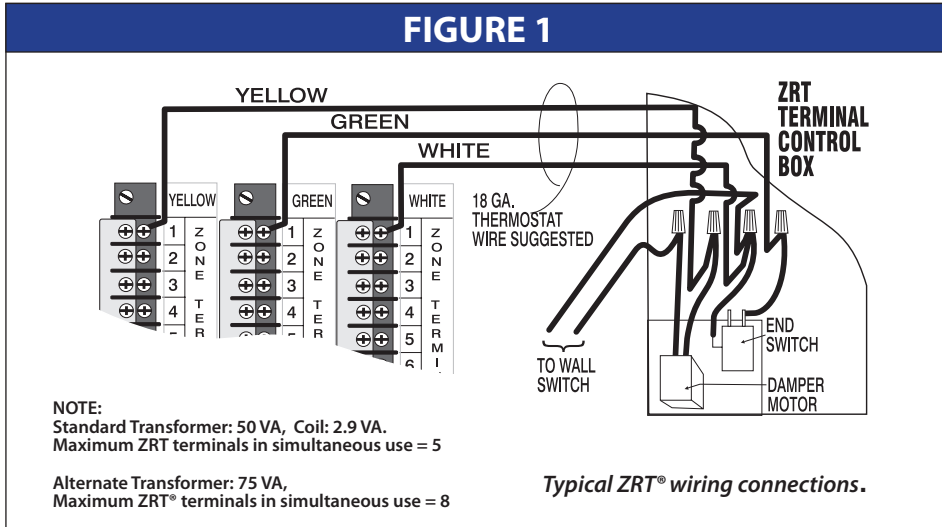

WIRING MUST COMPLY WITH ALL APPLICABLE CODES, ORDINANCES, AND REGULATIONS.

1. Connect ZRT® as shown in **Figure 1**.
2. Connect the ventilation fan equipment to the "Out to Fan" terminals on the control panel as shown in **Figure 3**.
3. Connect the main power to the "Input" terminals on the control panel as shown in **Figure 2**.

NOTE: Do not make any wiring connections or remove any wires to/from factory-installed wire terminals. Use only the terminal blocks provided.

WARRANTY: ALDES North America warrants the ZTC under normal use against defects in material and workmanship for 3 years from date of purchase. We will repair or replace any defect without charge, provided prompt return. Warranty is voided if there are any alterations. For more info call 1-800-255-7749.

FEATURES

- Class II (50 VA) inherently energy-limiting transformer.
- (Alternate) Class II 75 VA inherently energy-limiting transformer (Special order only).
- Non-resettable, non-replaceable over-current protection.
- For general use in Class II ventilating applications.
- Low-voltage terminal strips with standard terminal designation for easy wiring.
- 14-gauge lead wires.
- Secure mounting method from inside the control box cover.