

FANS

# PRODUCT BROCHURE



## VENTERGY® SERIES FANS

Single- and Multi-  
Port Ventilators

#HealthyLiving



### VS SERIES

Ventergy® Series VS Series In-line Ventilators are a superb choice for exhausting stale air from bathrooms, kitchens, laundry rooms, and garages. These fans are powerful enough to exhaust two rooms yet small enough to fit in tight spaces. By design, VS fans are exceptionally quiet, and they can be remote-mounted to ensure that occupants perceive no noise during fan operation.

Models VS4, VS6, and VS6 MAX meet ENERGY STAR efficiency criteria for low energy consumption.

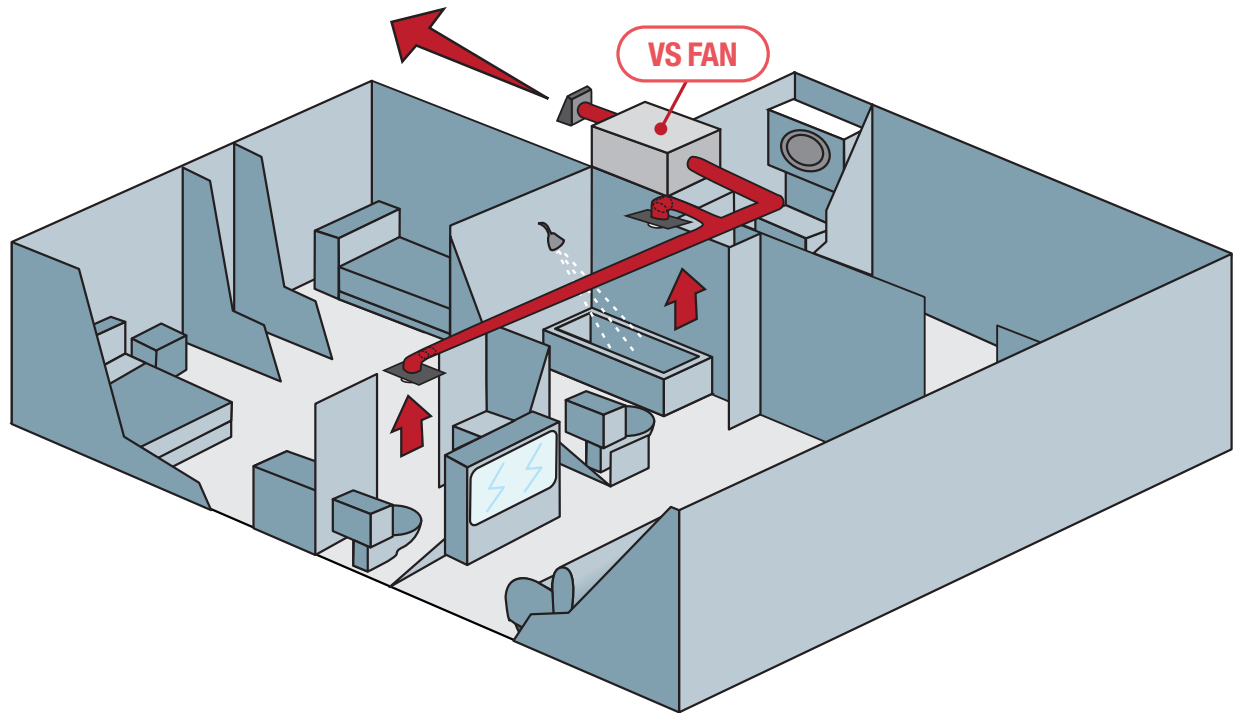
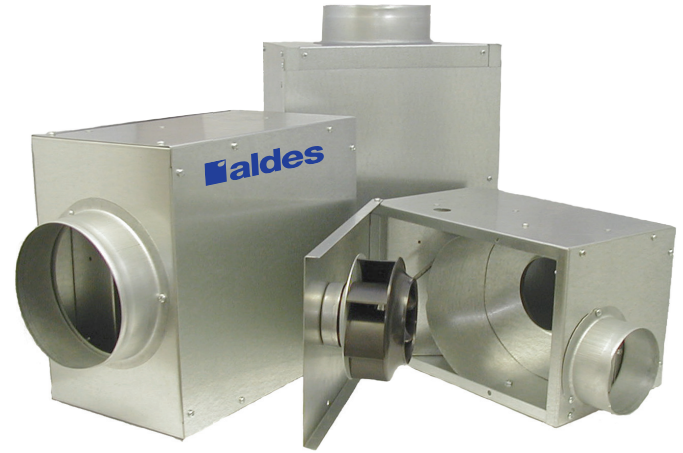

#### ELECTRICAL DATA

VS4: 115 V, 60 Hz, 20 W, 0.17 A, 2324 RPM  
 VS4 MAX: 115 V, 60 Hz, 34 W, 0.29 A, 3135 RPM  
 VS6: 115 V, 60 Hz, 41 W, 0.34 A, 2200 RPM  
 VS6 MAX: 115 V, 60 Hz, 59 W, 0.53 A, 2960 RPM

*Above ratings are intended for sizing electrical wiring only.  
 Actual consumption will be lower.*

#### FEATURES

- For intermittent or continuous use
- Low power consumption
- Condensation-proof IAQ lined cabinet
- Whisper-quiet operation
- Compact dimensions
- Ideal for zoning applications
- 100% speed controllable
- Easy-to-access motor / impeller

**ELECTRICAL AND AIRFLOW PERFORMANCE**

Model	Watts at 0.2" Ps	CFM vs. Static Pressure									ENERGY STAR Certified
		0"	0.2"	0.4"	0.6"	0.8"	1.0"	1.2"	1.4"	1.6"	
VS4	19.6	104	80	60	37	13	--	--	--	--	√
VS4 MAX	38.1	138	120	106	87	66	39	--	--	--	
VS6	40.1	220	170	141	105	78	46	19	--	--	√
VS6 MAX	63.3	287	261	234	205	178	151	120	89	38	√

\*Certified airflow rating at 0.2" w.g. is derated from actual test results per HVI Certification procedure 920. The HVI Certified Rate for VS4 = 80 CFM, VS4 MAX = 110 CFM, VS6 = 160 CFM, VS6 MAX = 250 CFM.

**COMPONENTS**

Heavy-gauge G90 galvanized steel construction

High-efficiency motor

Internally insulated with acoustic vapor barrier insulation

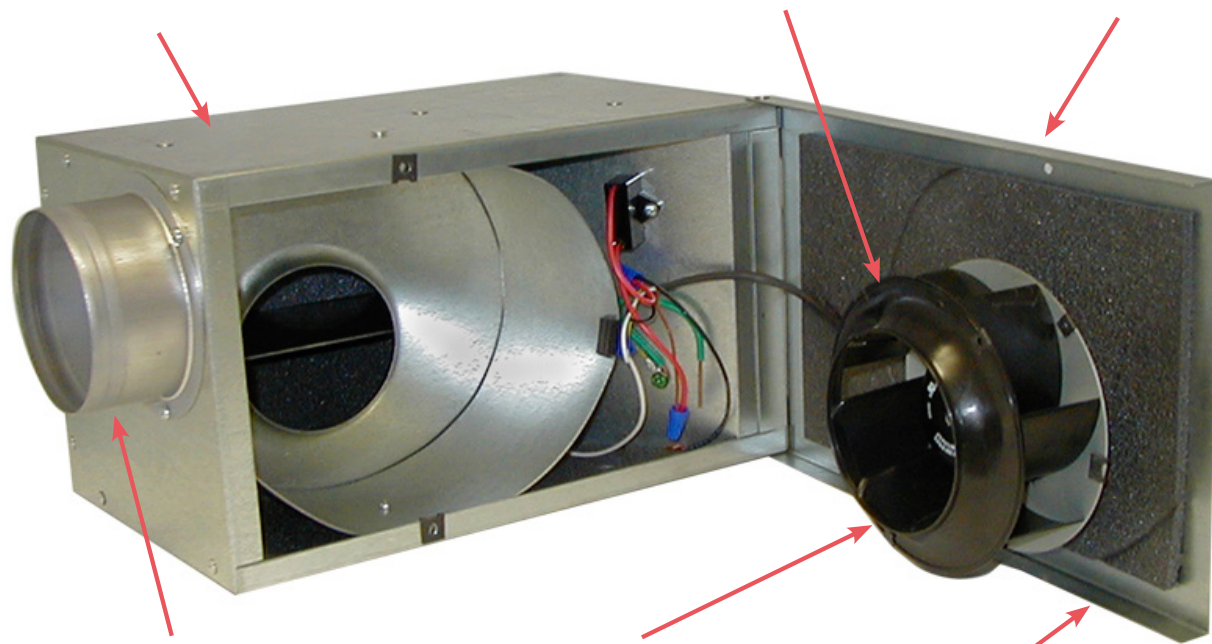

Seamless stamped steel duct collars eliminate leakage

Backward-inclined impeller allows for continuous operation and prevents dirt build-up

Drop-down hinged motor and filter access panels for easy service

# 4

## VENTERGY® SERIES FANS

### MPVS100 & MPVS120: MULTI-PORT EXHAUST VENTILATORS

#### MPVS100 & MPVS120

Ventergy® Series Multi-Port Ventilators (MPVS) can be used for central, continuous exhaust ventilation of bathrooms, kitchens, laundry rooms, and other rooms where humidity is a controlling factor. Unlike traditional bathroom fans that clutter the roofline with penetrations, these fans have a single exhaust discharge duct. Exhaust air can be drawn from two-to-four spaces using just one MPVS fan. Their compact, in-line design allows for remote mounting and supremely quiet performance.

The MPVS100 meets ENERGY STAR efficiency criteria for low energy consumption.

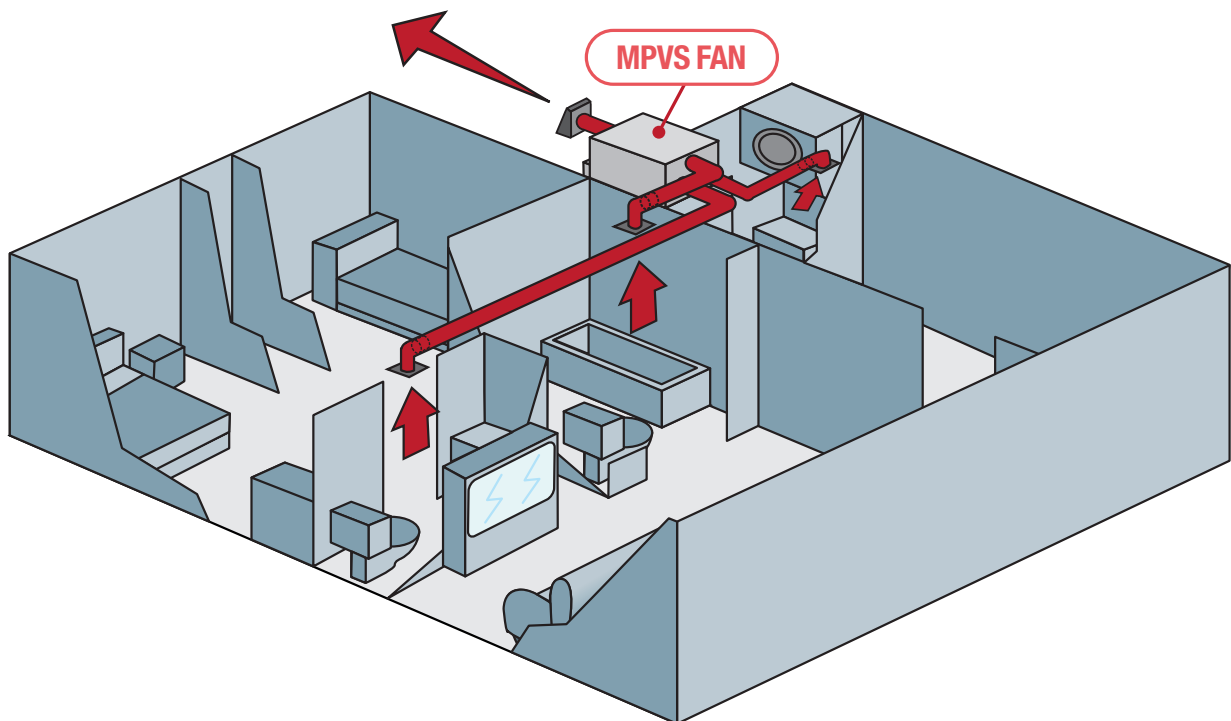

#### ELECTRICAL DATA

MPVS100: 115 V, 60 Hz, 21 W, 0.19 A, 2500 RPM

MPVS120: 115 V, 60 Hz, 34 W, 0.29 A, 3135 RPM

*Above ratings are intended for sizing electrical wiring only.  
Actual consumption will be lower.*

#### FEATURES

- Low power consumption
- Condensation-proof IAQ lined cabinet
- Whisper-quiet operation
- Compact dimensions
- Single exterior penetration
- Easy-to-access motor / impeller

**ELECTRICAL AND AIRFLOW PERFORMANCE**

Model	Watts at 0.2" Ps	CFM vs. Static Pressure						ENERGY STAR Certified
		0"	0.2"	0.4"	0.6"	0.8"	1.0"	
MPVS100	20.8	108	88	68	48	25	--	√
MPVS120	37.5	143	128	111	95	74	45	

\*Certified airflow rating at 0.2" w.g. is derated from actual test results per HVI Certification procedure 920. The HVI Certified Rate for MPVS100 = 80 CFM, MPVS120 = 120 CFM.

**AIRFLOW AND DUCT LENGTHS**

AIRFLOW CFM	3" INTAKE DUCT TO FAN Recommended Max. Duct Length from Grille to Fan (ft.)	
	SMOOTH	FLEXIBLE
10	225	180
20	65	50
30	30	25
40**	20	15
50**	10	10

TOTAL EXHAUST RATE CFM	FAN DISCHARGE DUCT Assumes low-pressure drop-vent cap		FOR EACH ELBOW DEDUCT
	4" SMOOTH	4" FLEXIBLE	
60	40 ft.	20 ft.	3" Diameter = 3 ft.
75	25 ft.	15 ft.	
90	18 ft.	12 ft.	
100	15 ft.	9 ft.	
120	11 ft.	8 ft.	
135	8 ft.	6 ft.	

\*This table should only be used as a general guide. Actual duct length allowances may be longer on some models. Contact the factory for assistance.

\*\*Constant Airflow Regulators not available over 35 CFM.

NOTE: If duct runs longer than permitted in the table above are required, use smooth ducting and/or increase the diameter.

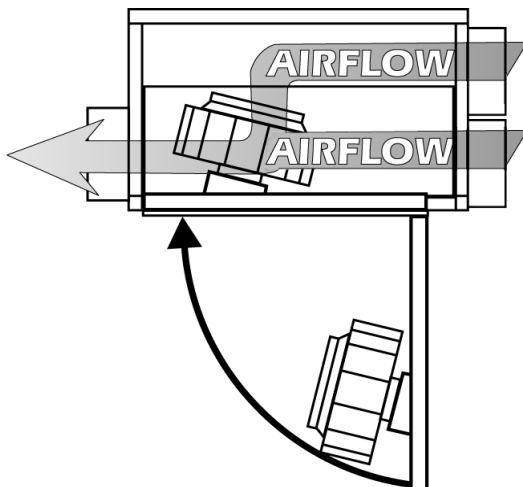

DROP-DOWN  
 HINGED ACCESS  
 PANEL FOR SIMPLE  
 SERVICE AND  
 INSPECTION

# 6

## VENTERGY® SERIES FANS

### MPVS150 & MPVS200: MULTI-PORT EXHAUST VENTILATORS

#### MPVS150 & MPVS200

Ventergy® Series Multi-Port Ventilators (MPVS) can be used for central, continuous exhaust ventilation of bathrooms, kitchens, laundry rooms, and other rooms where humidity is a controlling factor. The multi-port design, coupled with powerful-yet-efficient motors, allows a single MPVS fan to quietly exhaust two-to-four spaces. By eliminating the need for multiple exhaust fans, the MPVS makes it possible to have a single exterior exhaust penetration.

The MPVS150 and the MPVS200 meet ENERGY STAR efficiency criteria for low energy consumption.

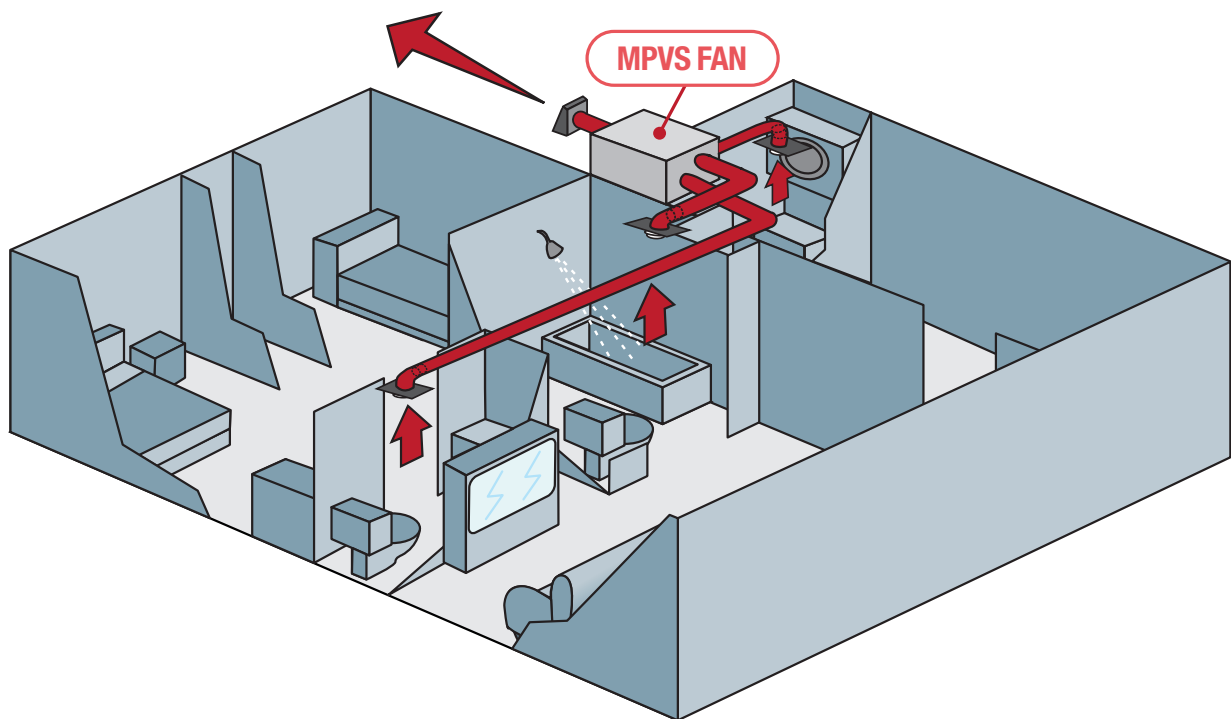
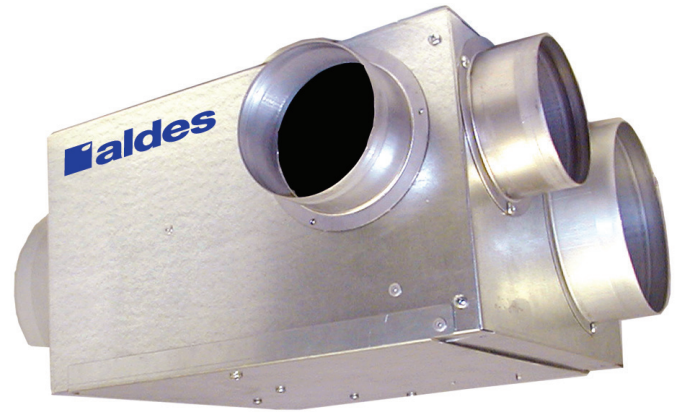

#### ELECTRICAL DATA

MPVS150: 115 V, 60 Hz, 41 W, 0.34 A, 2200 RPM

MPVS200: 115 V, 60 Hz, 59 W, 0.53 A, 2960 RPM

*Above ratings are intended for sizing electrical wiring only.  
Actual consumption will be lower.*

#### FEATURES

- ENERGY STAR Certified
- Low power consumption
- Condensation-proof IAQ lined cabinet
- Whisper-quiet operation
- Compact dimensions
- Single exterior penetration
- Easy-to-access motor / impeller

**ELECTRICAL AND AIRFLOW PERFORMANCE**

Model	Watts at 0.2" Ps	CFM vs. Static Pressure									ENERGY STAR Certified
		0"	0.2"	0.4"	0.6"	0.8"	1.0"	1.2"	1.4"	1.6"	
MPVS150	39.9	212	170	133	101	71	49	17	--	--	√
MPVS200	62.5	287	250	227	198	168	136	100	65	24	√

\*Certified airflow rating at 0.2" w.g. is derated from actual test results per HVI Certification procedure 920.  
 The HVI Certified Rate for MPVS150 = 170 CFM, MPVS200 = 250 CFM.

**AIRFLOW AND DUCT LENGTHS**

AIRFLOW CFM	INTAKE DUCT TO FAN Recommended Max. Duct Length from Grille to Fan (ft.)			
	4" SMOOTH	4" FLEXIBLE	6" SMOOTH	6" FLEXIBLE
50	50	30	400	250
60	40	20	280	175
80	--	--	170	95
100	--	--	110	70

TOTAL EXHAUST RATE CFM	FAN DISCHARGE DUCT Assumes low-pressure drop-vent cap		FOR EACH ELBOW DEDUCT
	6" SMOOTH	4" FLEXIBLE	
175	20 ft.	10 ft.	4" Diameter = 4 ft. 6" Diameter = 7 ft.
200	15 ft.	8 ft.	
225	13 ft.	7 ft.	

\*This table should only be used as a general guide. Actual duct length allowances may be longer on some models. Contact the factory for assistance.

NOTE: 3" Ducting may be substituted to permit installation in partition walls. Smaller diameter ducting has increased resistance to airflow. For each foot of 3" ducting substituted for 4" diameter duct, reduce the allowable duct length by 3 feet. If duct runs longer than permitted in the table above are required, use smooth ducting and/or increase the diameter.

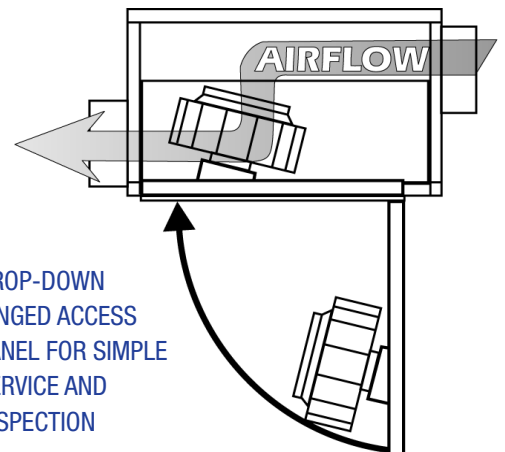
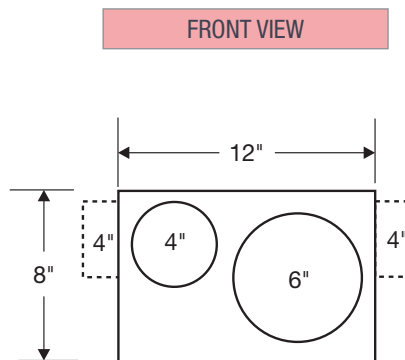
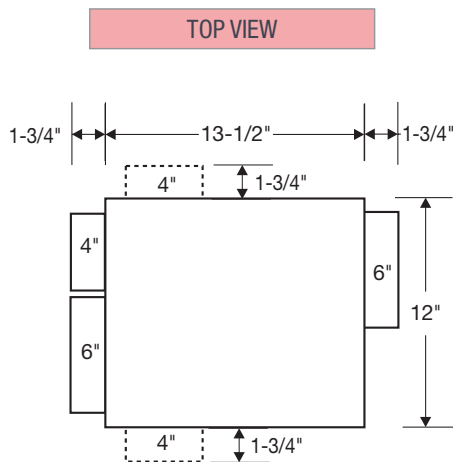

**DROP-DOWN  
 HINGED ACCESS  
 PANEL FOR SIMPLE  
 SERVICE AND  
 INSPECTION**

NOTE: Location(s) of field-installed 4" side-tap collar(s) shown as dashed lines.

**VENTERGY® SERIES FANS**

BVS120 &amp; BVS200: BLENDING/FILTERING VENTILATORS

**BVS120 & BVS200**

Ventergy® Series Blending/Filtering Ventilators (BVS) are great solutions for bringing fresh air into tightly constructed homes. As outside air enters the BVS, it mixes with return air from up to five bedrooms or other areas that are typically not served by a central thermostat. The resulting tempered air passes through a filter before being distributed to living areas. The BVS is an efficient way to enhance thermal comfort. By slightly pressurizing the structure, the BVS prevents the introduction of contaminants and reduces the risk of backdrafting heating appliances, water heaters, and fireplaces.

The BVS120 and BVS200 meet ENERGY STAR efficiency criteria for low energy consumption.

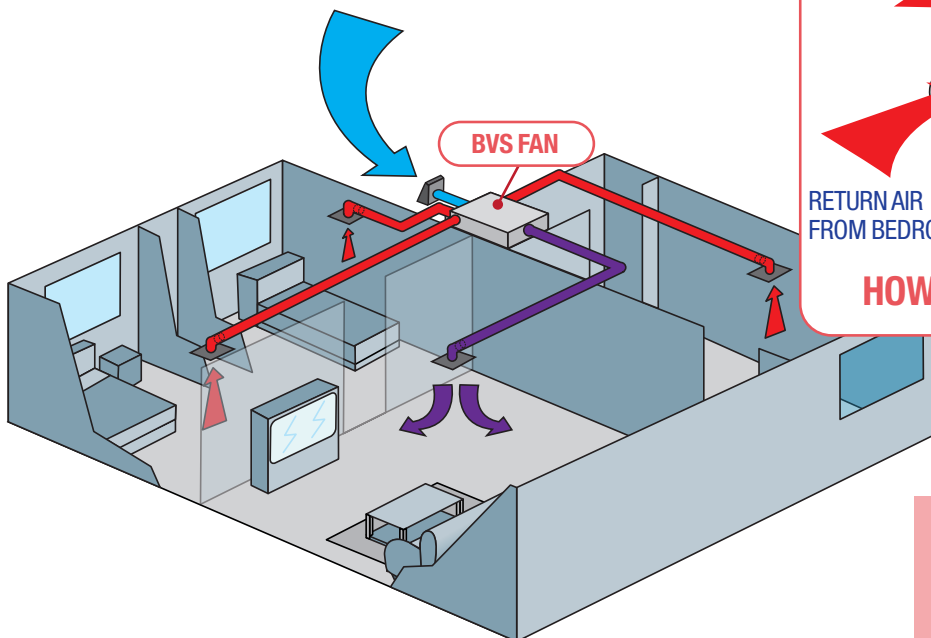
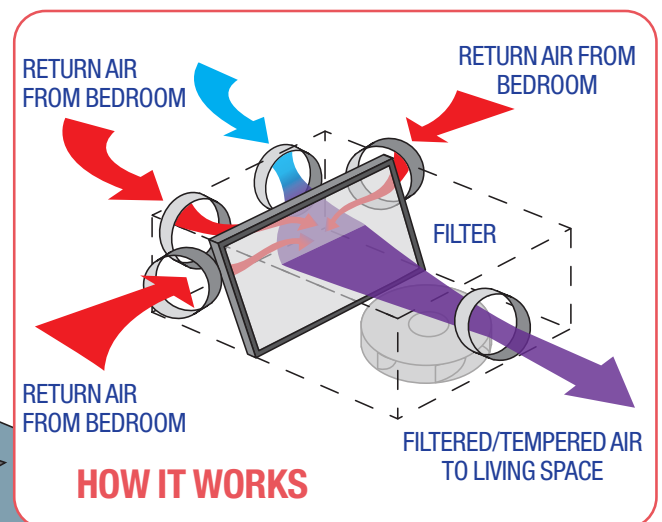
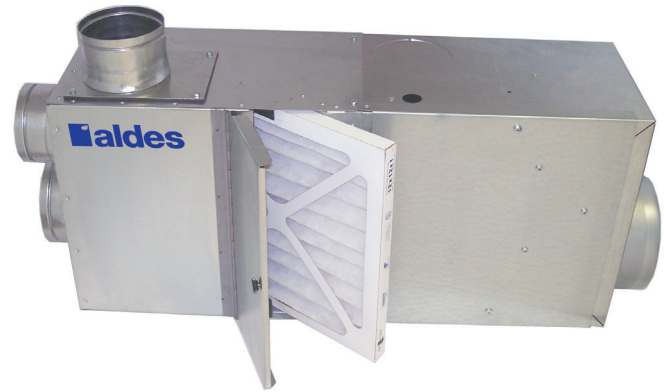
**ELECTRICAL DATA**

BVS120: 115 V, 60 Hz, 41 W, 0.34 A, 2200 RPM  
 BVS200: 115 V, 60 Hz, 59 W, 0.53 A, 2960 RPM

*Above ratings are intended for sizing electrical wiring only.  
 Actual consumption will be lower.*

**FEATURES**

- 2-4 intake points
- Ideal for continuous use
- Low power consumption
- ENERGY STAR Certified
- Condensation-proof IAQ lined cabinet
- Whisper-quiet operation
- Compact dimensions
- 100% speed controllable
- Easy-to-access filter / motor / impeller
- Multiple filter options



**ELECTRICAL AND AIRFLOW PERFORMANCE**

Model	Watts at 0.2" Ps	CFM vs. Static Pressure						ENERGY STAR Certified
		0.0"	0.2"	0.4"	0.6"	0.8"	1.0"	
BVS120	34.2	184	140	115	85	55	26	√
BVS200	56.6	247	220	192	164	136	101	√

\*Certified airflow rating at 0.2" w.g. is derated from actual test results per HVI Certification procedure 920.  
 The HVI Certified Rate for BVS120 = 140 CFM, BVS200 = 220 CFM.

**COMPONENTS**

MERV 8 pleated filter or A+2000 electrostatic permanent filter options

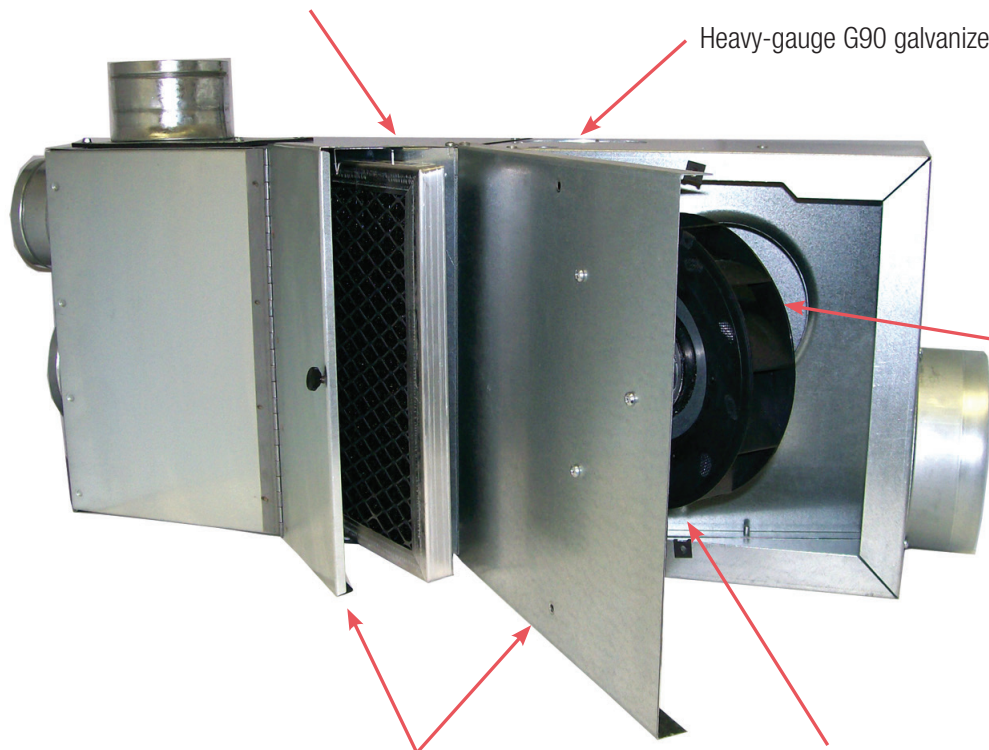

Heavy-gauge G90 galvanized steel construction

Internally insulated with acoustic vapor barrier insulation

Drop-down hinged motor and filter access panels for easy service

High-efficiency motor meets ENERGY STAR performance criteria

**MAINTENANCE**

**Monthly:** Clean the exhaust and supply grilles.

**Seasonally:** Clean the fresh air intake wall hood.

# 10

## VENTERGY® SERIES FANS FSVS140: FILTERING SUPPLY VENTILATORS

### FSVS140

Ventergy® Series Filtering Supply Air Ventilators (FSVS) are designed to provide precise amounts of outdoor air to the occupied space. Fresh air passes through a filter before being distributed, either via the supply stream of a forced-air unit, or through an overhead return in the main living area. The low-volume fresh air provided by the FSVS140 keeps indoor air quality high, and the space stays positively pressurized to avoid backdrafts and unwanted infiltration.

The FSVS140 meets ENERGY STAR efficiency criteria for low energy consumption.

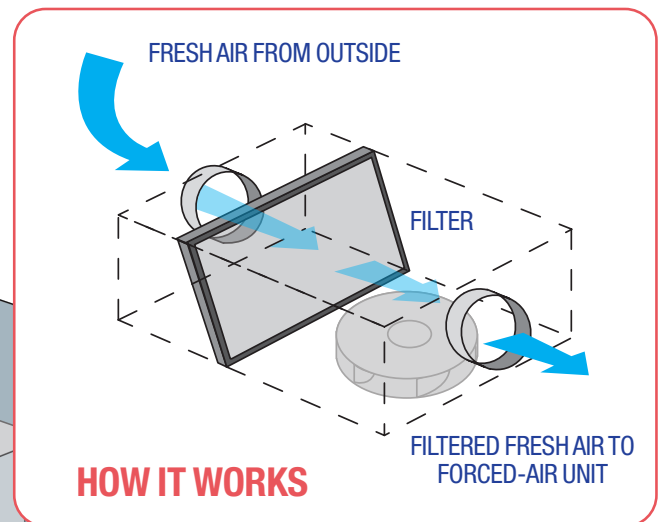
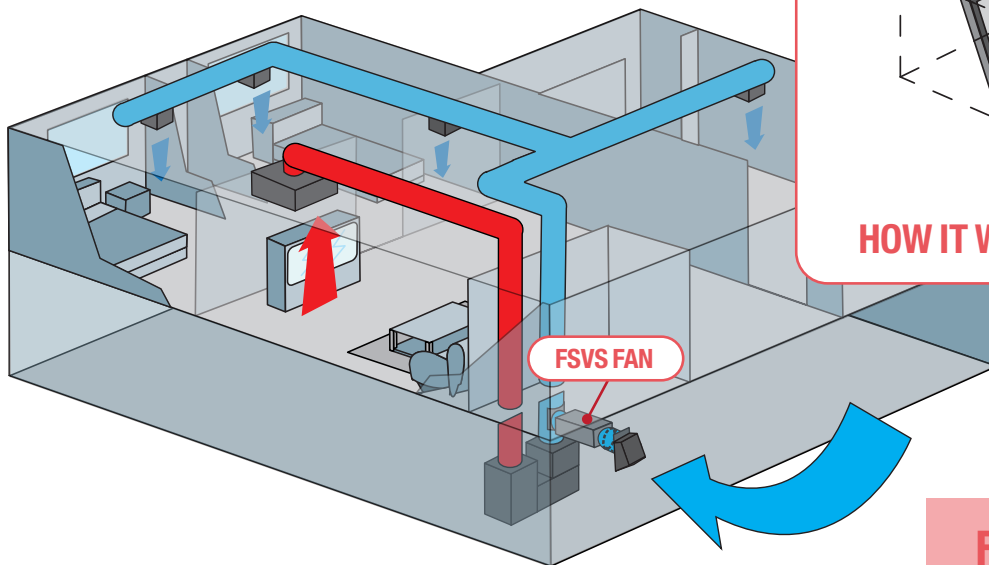
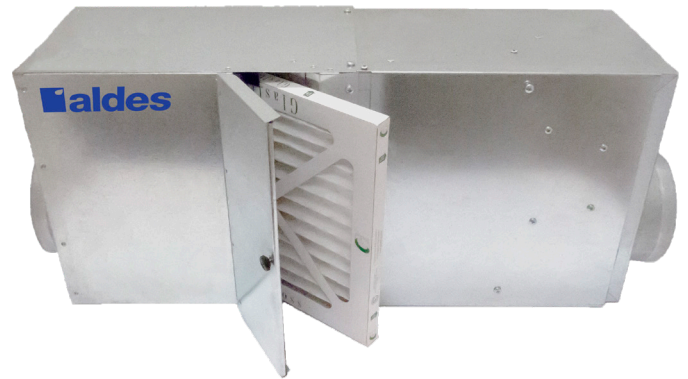

### FEATURES

- Low power consumption
- ENERGY STAR Certified
- Condensation-proof IAQ lined cabinet
- Whisper-quiet operation
- Compact dimensions
- 100% speed controllable
- Easy-to-access filter / motor / impeller
- Multiple filter options

#### ELECTRICAL DATA

115 V, 60 Hz, 41 W, 0.34 A, 2200 RPM

*Above ratings are intended for sizing electrical wiring only.  
Actual consumption will be lower.*

**ELECTRICAL AND AIRFLOW PERFORMANCE**

Model	Watts at 0.2" Ps	CFM vs. Static Pressure					
		0.0"	0.2"	0.4"	0.6"	0.8"	1.0"
FSVS140	36.7	178	140	110	79	51	22

\*Certified airflow rating at 0.2" w.g. is derated from actual test results per HVI Certification procedure 920.  
 The HVI Certified Rate for FSVS140 = 140 CFM.

**COMPONENTS**

MERV 8 pleated filter or A+2000 electrostatic permanent filter options

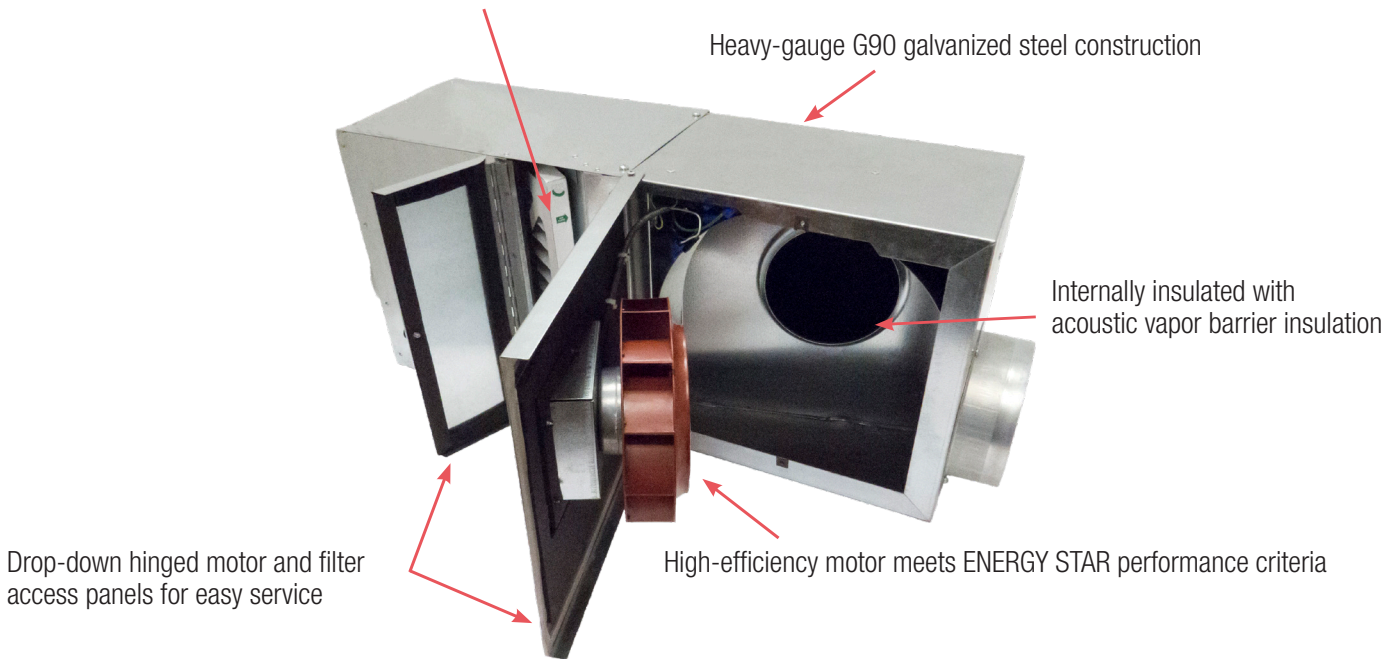

**ALTERNATIVE INSTALLATION FOR NON-AHU FAN INTERLOCK CONTROL**

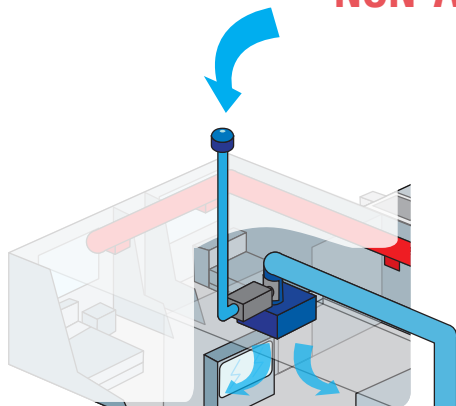

For continuous operation, the FSVS should be installed separately from the forced A/C system to prevent moisture in the air from condensing inside cold ducts, or cold air coming in contact with the heat exchanger.

◀ **Example:** Installed so fresh air is introduced into the large living area via the overhead return.

# #HealthyLiving

Engineering tomorrow's solutions is more than an idea – it is a guiding principle. Every Aldes product is equal parts innovation and experience. Efficient and respectful solutions of the environment which allow to renew and purify the indoor air delivering improved air quality. From automatic airflow controls to advanced heat and energy recovery ventilators, Aldes products can be found in high-performing homes, schools, hotels and buildings across North America. Healthy Living, much more than a movement, embody our benevolence, our sense of responsibility and pioneering spirit.



For more information, contact your  
Aldes sales advisor, visit [aldes-na.com](http://aldes-na.com),  
or find us on



Aldes North America  
USA 800.255.7749 CAN 800.262.0916

