

DABLDRN | Bar Linear Register w/ No Flange & Removable Core

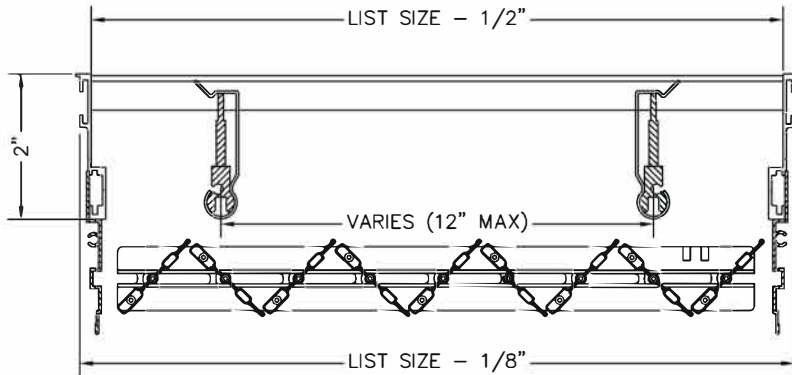

- Fully extruded, high quality aluminum construction for a stylish appearance.
- No flange frame designed for a clean, built-in appearance.
- Core is fully removable, and held in place with pressure clips.
- Opposed blade damper with slide operator.
- Fixed blades parallel to the long dimension.
- Sections over 84" are joined for continuous lengths with aligning pins provided.
- Available on 1/2" increments as standard. Custom sizes available down to 1/16" increments.
- Available with durable powder coat finish.

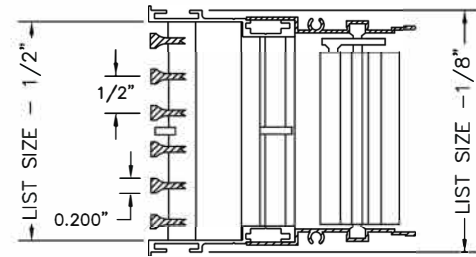
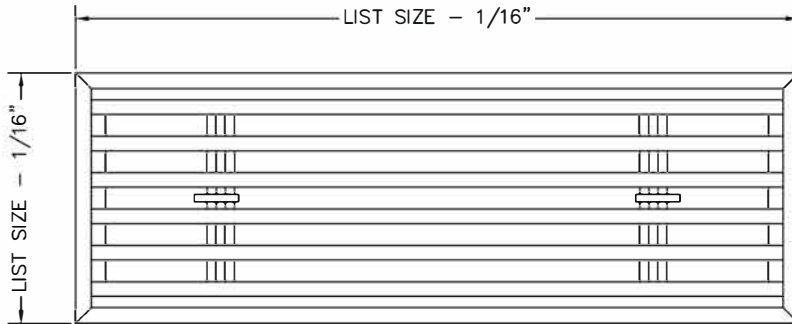

1. Select a Blade Option

- | | |
|---|--|
| <input type="checkbox"/> 00 - 0° Deflection | <input type="checkbox"/> 30 - 30° Deflection |
| <input type="checkbox"/> 01 - 0° Pencil Proof | <input type="checkbox"/> 82 - 0° Air Flow |
| <input type="checkbox"/> 15 - 15° Deflection | <input type="checkbox"/> 84 - 0° Heel Proof |

2. Select a Mounting Option

- | |
|---|
| <input type="checkbox"/> C - Concealed Brackets |
| <input type="checkbox"/> D - Sidewall Screw Holes |
| <input type="checkbox"/> TB - No Mounting |



3. Specify the Length x Height Dimensions

Inches MM _____ x _____

Additional Option

See specific submittal pages for options listed below.

- E - Reinforced Floor

4. Select a Finish

- | | |
|-------------------------------------|--|
| <input type="checkbox"/> W - White | <input type="checkbox"/> FB - Flat Black |
| <input type="checkbox"/> S - Silver | <input type="checkbox"/> Special: _____ |
| <input type="checkbox"/> B - Brown | |
| <input type="checkbox"/> M - Mill | |

5. Select the Lead Time

- | |
|--|
| <input type="checkbox"/> 3 Day Ship |
| <input type="checkbox"/> Next Friday |
| <input type="checkbox"/> Standard Delivery |

Project / Location: _____
 Architect: _____
 Engineer: _____
 Contractor: _____



BLADE OPTIONS

-00

0° 13/64" blades on 1/2" centers

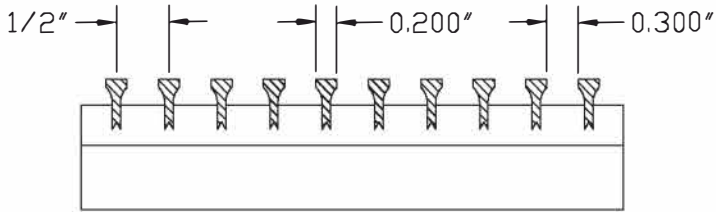

-01

0° 1/4" blades on 1/2" centers

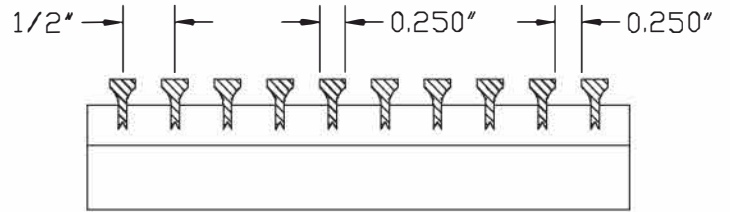

-15

15° 13/64" blades on 1/2" centers

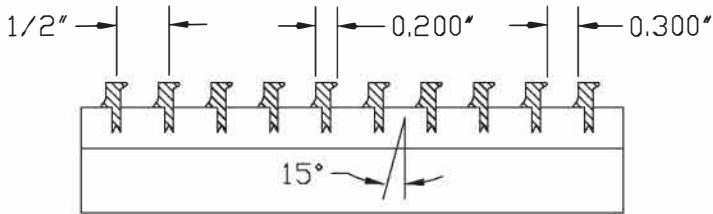

-30

30° 13/64" blades on 1/2" centers

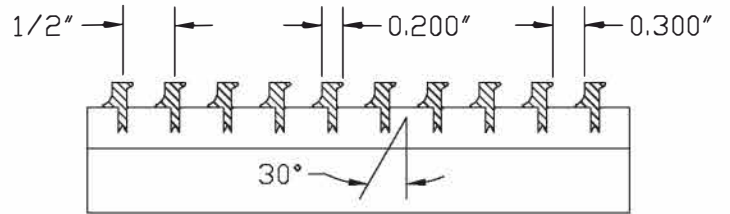

-82

0° 1/8" blades on 1/2" centers

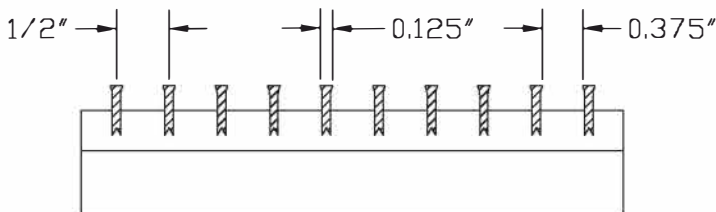

-84

0° 1/8" blades on 1/4" centers

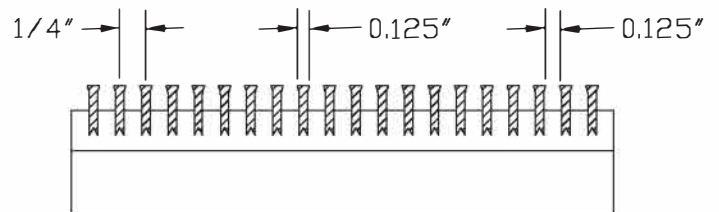

MOUNTING

-A

Screw Holes

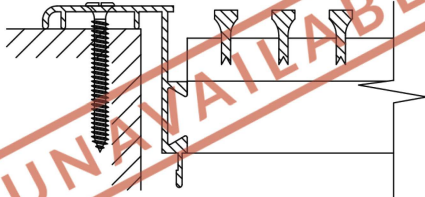

Color matched screws with countersunk screw holes.

-B

Spring Clips

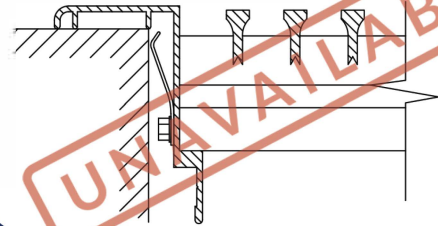

Hidden clips behind the flange to keep the grille secure in the opening. Only suitable for floor & sill applications.

These mounting options are only available with flanged grilles.



-C

Concealed Brackets

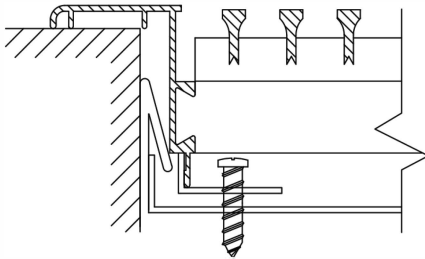

Product is fastened to duct-mounted brackets, which are concealed behind the blades.

-D

Sidewall Screw Holes

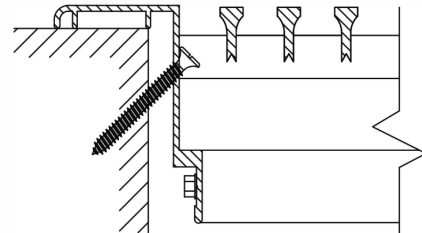

Screw holes are drilled at a 45° angle on inner flange. Only available with Removable Core.

-TB

No Mounting

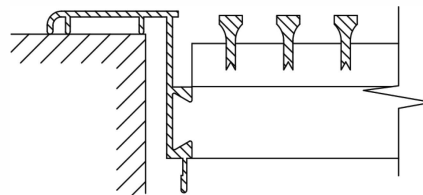

Designed for lay-in ceiling and custom applications. For lay-in, order 2" under to account for flange.

e.g. 22" x 10" will have O.D. 23-11/16" x 11-11/16" and fit a standard 24" x 12" T-bar opening.