

DABLRJ | Bar Linear Grille w/ Mud-In Flange & Removable Core

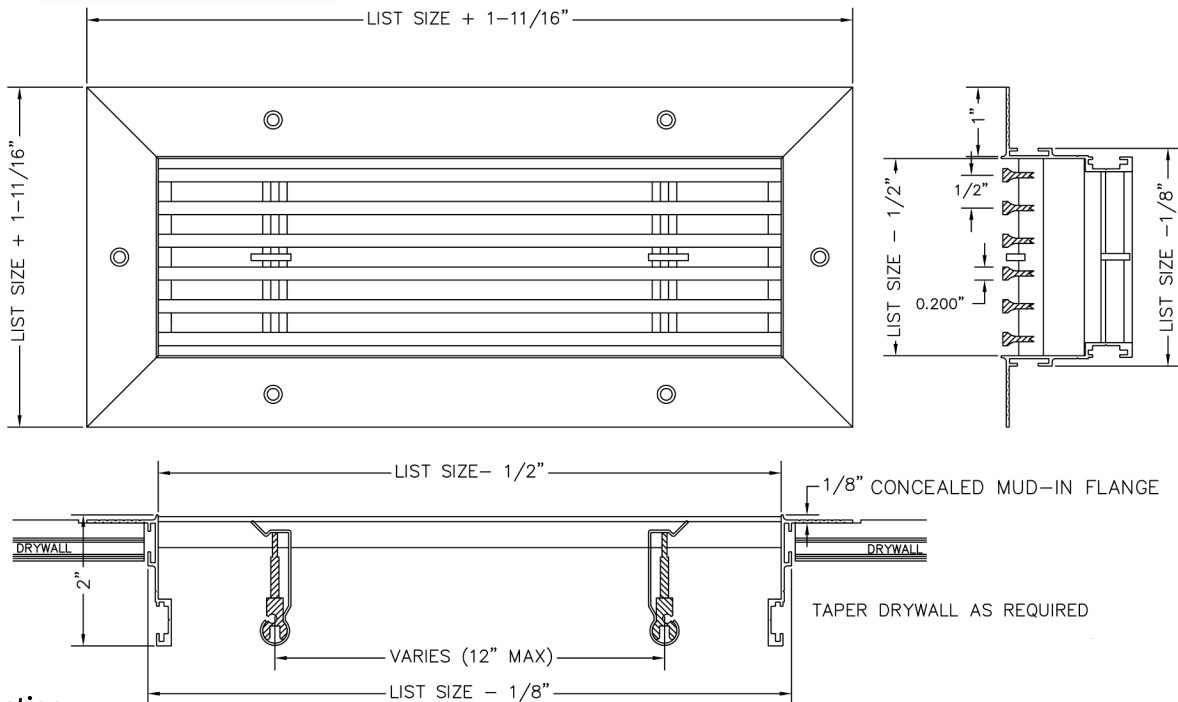

- Mud-in, recessed flange frame to be taped & plastered over.
- Fully extruded, high quality aluminum construction for a stylish appearance.
- Core is fully removable, and held in place with pressure clips.
- Fixed blades parallel to the long dimension.
- Sections over 84" are joined for continuous lengths with aligning pins provided.
- Available on 1/2" increments as standard. Custom sizes available down to 1/16" increments.
- Available with durable powder coat finish.



1. Select a Blade Option

- | | |
|--|---|
| <input type="checkbox"/> <u>00</u> - 0° Deflection | <input type="checkbox"/> <u>30</u> - 30° Deflection |
| <input type="checkbox"/> <u>01</u> - 0° Pencil Proof | <input type="checkbox"/> <u>82</u> - 0° Air Flow |
| <input type="checkbox"/> <u>15</u> - 15° Deflection | <input type="checkbox"/> <u>84</u> - 0° Heel Proof |

2. Select a Mounting Option

- | | |
|--|--|
| <input type="checkbox"/> <u>A</u> - Screw Holes | <input type="checkbox"/> <u>D</u> - Sidewall Screw Holes |
| <input type="checkbox"/> <u>C</u> - Concealed Brackets | <input type="checkbox"/> <u>TB</u> - No Mounting |

3. Specify the Length x Height Dimensions

- Inches MM _____ x _____

4. Select a Finish

- | | |
|--|---|
| <input type="checkbox"/> <u>W</u> - White | <input type="checkbox"/> <u>FB</u> - Flat Black |
| <input type="checkbox"/> <u>S</u> - Silver | <input type="checkbox"/> Special: _____ |
| <input type="checkbox"/> <u>B</u> - Brown | |
| <input type="checkbox"/> <u>M</u> - Mill | |

5. Select a Lead Time

- | |
|--|
| <input type="checkbox"/> 3 Day Ship |
| <input type="checkbox"/> Next Friday |
| <input type="checkbox"/> Standard Delivery |

Invisible lip design allows for a true frameless appearance, and easier installation.

3 DAY SHIP
ANY SIZE. ANY MODEL.
GUARANTEED

Additional Options

See specific submittal pages for options listed below.

- D - Opposed Blade Damper

Project / Location: _____

Architect: _____

Engineer: _____

Contractor: _____

BLADE OPTIONS

-00

0° 13/64" blades on 1/2" centers

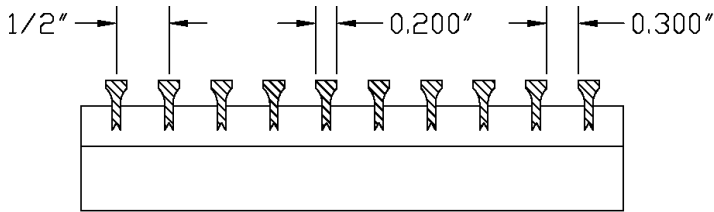

-01

0° 1/4" blades on 1/2" centers

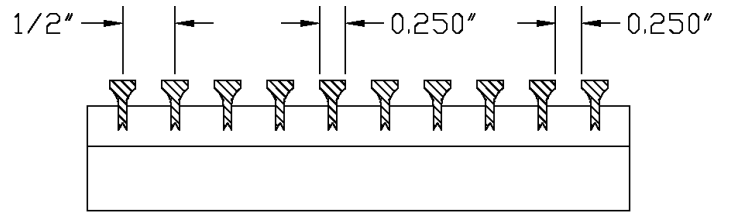

-15

15° 13/64" blades on 1/2" centers

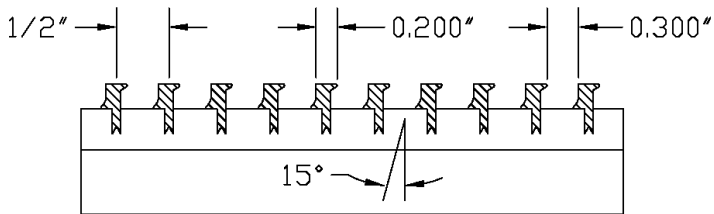

-30

30° 13/64" blades on 1/2" centers

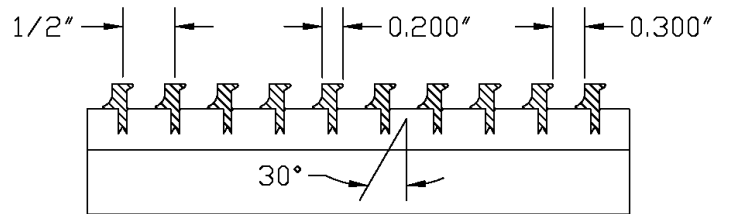

-82

0° 1/8" blades on 1/2" centers

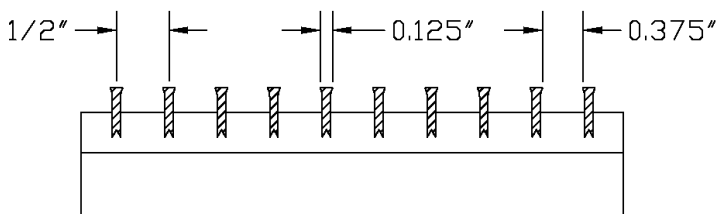

-84

0° 1/8" blades on 1/4" centers

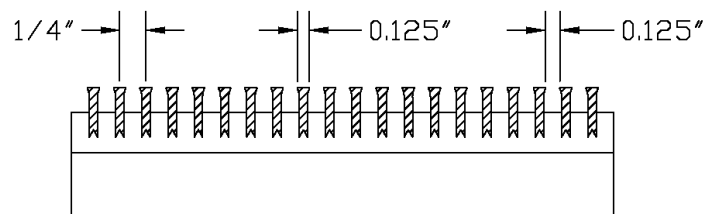

MOUNTING

-A
Screw Holes

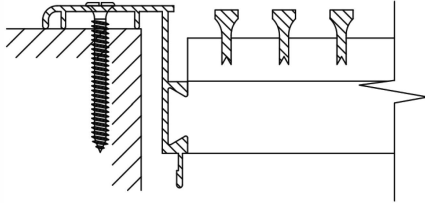

Color matched screws with countersunk screw holes.

-B
Spring Clips

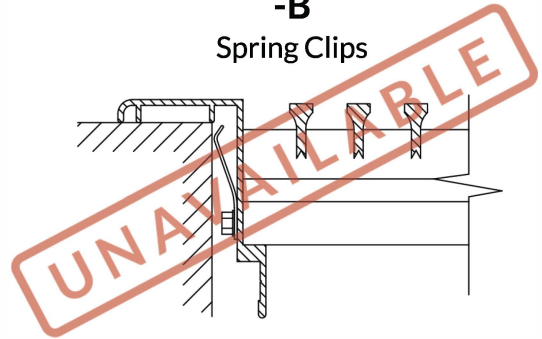

Hidden clips behind the flange to keep the grille secure in the opening. Only suitable for floor & sill applications.

-C
Concealed Brackets

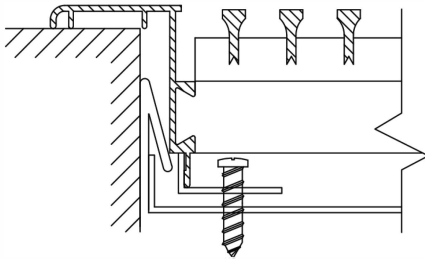

Product is fastened to duct-mounted brackets, which are concealed behind the blades.

-D
Sidewall Screw Holes

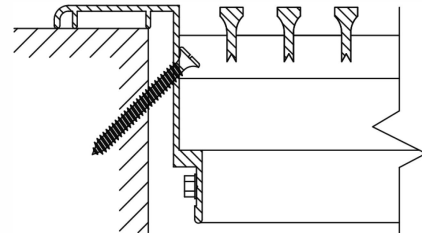

Screw holes are drilled at a 45° angle on inner flange. Only available with Removable Core.

-TB
No Mounting

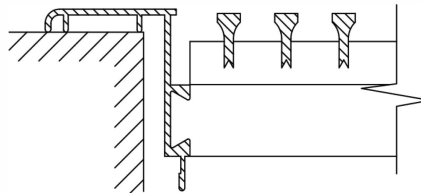

Designed for lay-in ceiling and custom applications. For lay-in, order 2" under to account for flange.

e.g. 22" x 10" will have O.D. 23-11/16" x 11-11/16" and fit a standard 24" x 12" T-bar opening.