

Electronic Countdown Timer Switch (Single Pole)

Cat. No. FD 60EM

Ratings: 15 A Resistive, 1,800 W Incandescent/Halogen, 600 W LED/CFL, 1,200 VA ELV/MLV/Fluorescent, 1/2 HP or 9.8 A Motor/Fan, 120 VAC, 60 Hz

WARNINGS:

- **TO AVOID FIRE, SHOCK OR DEATH: TURN OFF POWER AT CIRCUIT BREAKER OR FUSE AND TEST THAT THE POWER IS OFF BEFORE WIRING!**
- **TO AVOID PERSONAL INJURY OR PROPERTY DAMAGE, DO NOT** install to control a receptacle, or a load in excess of the specified rating.
- **DO NOT** use to control lighting if it is the only light source in the area.
- To be installed and/or used in accordance with electrical codes and regulations.
- If you are not sure about any part of these instructions, consult an electrician.

CAUTIONS:

- **DO NOT** use disinfecting products, including foggers, sprays or other types of atomized cleaning agents.
- **DO NOT** spray liquid onto the product.
- To clean, use a damp cloth with mild soap.
- No user serviceable components. **DO NOT** attempt to service or repair.
- Use this device **WITH COPPER OR COPPER-CLAD WIRE ONLY.**

PK-A3460-10-00-2A

INSTALLATION INSTRUCTIONS

ENGLISH

Features

- Easy operation with four preset buttons and one "OFF" button.
- Simple press and hold override function for 24-hour override.
- For Single-Pole wiring only.
- With Zero Cross turn-ON technology that extends the life of the switching relays (turns ON at the minimum voltage).
- Color change kits are available in white, light almond, ivory, black, brown, and gray (DTKIT-00x).
- Available with six countdown timer options (15, 30, 60 minutes, and 2, 4, 12 hours).
- Available in a 20A larger load, multi-way, or multi-timer (Cat. No. DT2xx).

You Will Need:

- Slotted/Phillips screwdriver
- Electrical tape
- Cutters
- Pliers

Installation

WARNING: TO AVOID FIRE, SHOCK OR DEATH, turn OFF power at circuit breaker or fuse and test that the power is OFF before wiring!

1. Identify your wires (most common shown).

NOTE: A Neutral wire (if present) or a Ground wire is required for operation. If the wiring in the wallbox does not resemble this configuration, consult an electrician.

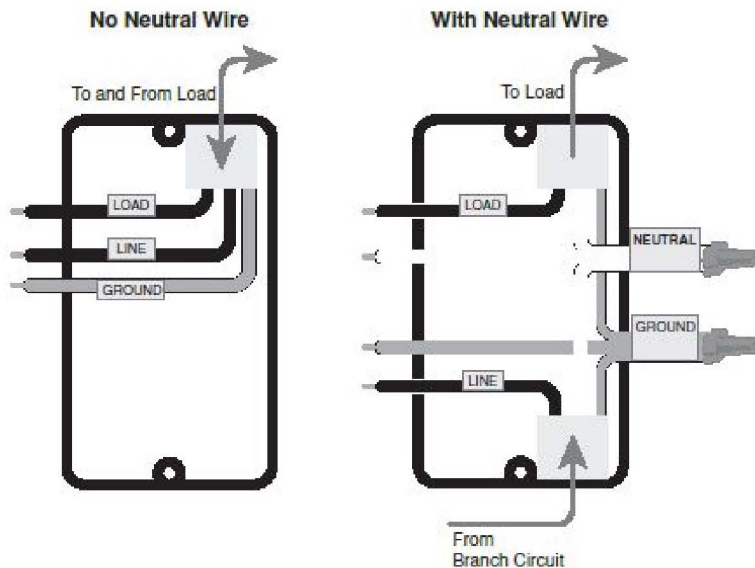

2a. Wire device (when Neutral is NOT present).

Work on one connection at a time, and connect wires as shown.

NOTE: This device is designed so that the line and load wires can be wired interchangeably.

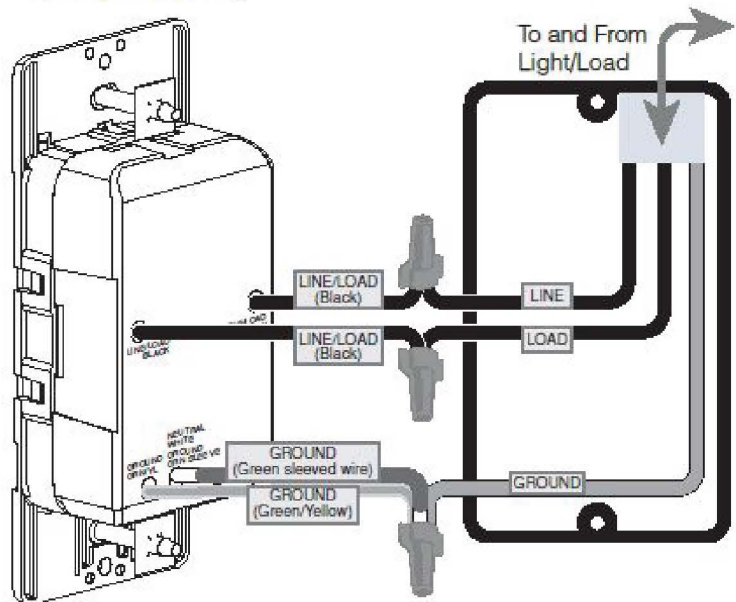

2b. Wire device (when Neutral is present).

- Remove the green sleeve from the white wire.
 - Work on one connection at a time, and connect the wires as shown.
- NOTE:** This device is designed so that the line and load wires can be wired interchangeably.

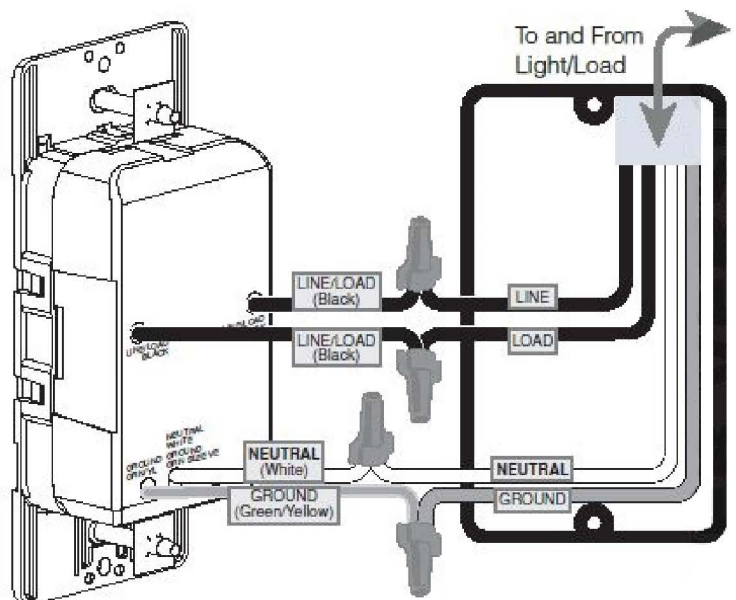

3. Test and mount.

- Restore power. Wait 20 seconds for timer to power up.
NOTE: The bottom green LED blinks once every 5 seconds during power up.
- Press any timer button to turn the load ON.
NOTE: If load does not turn ON, refer to the "What to do if..." section.
- Turn OFF power at circuit breaker before completing the installation.
- Gently push wires into wallbox. Use the screws to attach timer to wallbox.
- Install wallplate.
- Restore power.

LED Location and Status

- Four (4) timer buttons and an OFF button.
- Each timer button has an adjacent green LED to indicate the current countdown time.
- The green bottom Locator LED is ON when the load is OFF, and it is OFF when the load is ON.

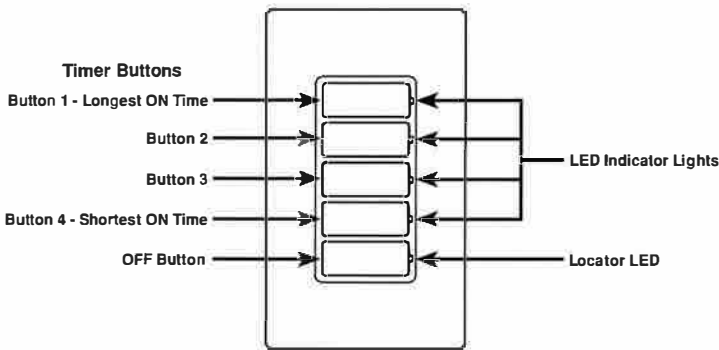

Mode	Location	Status
Power Up	Next to OFF button	Blinks once every 5 seconds.
Load OFF	Next to OFF button	ON
Load ON	Next to Button 1, 2, 3, or 4	ON
24-Hour Timer Override	Next to Button 1	Blinks once per second.
Last Minute Load Is ON	Next to Button 4	Blinks once per second.

Operation

1. To turn the load ON, press one of the timer buttons. Each button has a preset countdown time. The green LED adjacent to the selected button illuminates, and the load stays on for the selected time period.
2. To select a different countdown time, press the button that corresponds to the desired time. The LED adjacent to the selected button illuminates, and the load stays on for the newly selected timer period.
3. To turn the load OFF, press the OFF button, or wait until the selected amount of time elapses. The LED adjacent to each button turns OFF as time passes to the next lower preset level.

Timer Override

To override the timer countdown, press and hold the top button for more than 5 seconds. The LED blinks once per second to indicate the timer is in the EXTENDED ON state. The timer automatically turns OFF after 24 hours. To exit the EXTENDED ON state, press any timer button or the OFF button.

Model	Countdown Timer Options				
	Button 1	Button 2	Button 3	Button 4	Button 5
DT115	15 minutes	10 minutes	5 minutes	2 minutes	Off
DT130	30 minutes	15 minutes	10 minutes	5 minutes	Off
DT160	60 minutes	30 minutes	20 minutes	10 minutes	Off
DT102	2 hours	1 hour	30 minutes	15 minutes	Off
DT104	4 hours	2 hours	1 hour	30 minutes	Off
DT112	12 hours	8 hours	4 hours	2 hours	Off

Changing Your Device Color

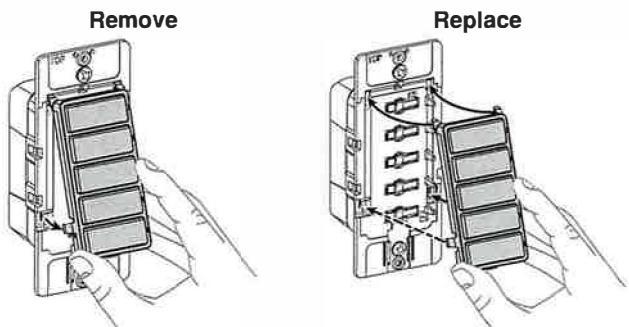

Color change kits are available in white, light almond, ivory, black, brown, and gray (DTKIT-00x).

What to do if...

- **Intermittent operation**
 - Check that the load does not have a bad connection.
 - Check if wires are secured firmly to the leads of timer switch.
- **Load does not turn ON and Locator LED does not turn ON**
 - Check if the circuit breaker or fuse has tripped.
 - Check if the load has burned out.
 - Make sure the Neutral or Ground connection is wired properly.
 - Make sure that the green-sleeved wire is connected properly.

FCC Compliance Statement:

This device complies with Part 15 of the FCC Rules. Operation is subject to following two conditions: (1) this device may not cause harmful interference, and (2) this device must accept any interference received, including interference that may cause undesired operation of the device. This equipment has been tested and found to comply with the limits for a Class B Digital Device, pursuant to Part 15 of the FCC Rules. These limits are designed to provide reasonable protection against harmful interference in a residential installation. This equipment generates, uses, and can radiate radio frequency energy and, if not installed and used in accordance with the instructions, may cause harmful interference to radio communications. However, there is no guarantee that interference will not occur in a particular installation. If this equipment does cause harmful interference to radio or television reception, which can be determined by turning the equipment OFF and ON, the user is encouraged to try to correct the interference by one or more of the following measures:

- Reorient or relocate the receiving Antenna.
- Increase the separation between the equipment and the receiver.
- Consult the dealer or an experienced radio/tv technician for help.
- Connect the equipment into an outlet on a circuit different from that to which the receiver is connected.

FCC Statement:

Any changes or modifications not expressly approved by Fantech could void the user's authority to operate the equipment.

IC Statement:

This device complies with Industry Canada licence-exempt RSS standard(s). Operation is subject to the following two conditions: (1) this device may not cause interference, and (2) this device must accept any interference, including interference that may cause undesired operation of the device.

Fantech and the Fantech logo are the registered trademarks of Systemair Inc.

FOR US AND CANADA

This product has a 1 year warranty. For warranty information, make a scan of the QR code on this sheet. If additional support is needed to retrieve the warranty, visit fantech.net; call (800) 747-1762 (US), (800) 565-3548 (Canada); email support@fantech.net; or mail us at 10048 Industrial Blvd, Lenexa, KS 66215 United States or at 50 Kanfåkt Way, Bouctouche, NB E4S 3M5 Canada.



Technical Support
US: 800.747.1762, ext. 1
Canada: 800.747.1762, ext. 3