

ADDAVENT 1800

Gable Mount

Power Vent



WARNING —TO REDUCE THE RISK OF FIRE, ELECTRIC SHOCK, OR INJURY TO PERSONS, OBSERVE THE FOLLOWING:

- A. Use this unit only in the manner intended by the manufacturer. If you have any questions, contact the manufacturer.
- B. Before servicing or cleaning unit, switch power off at service panel and lock service panel to prevent power from being switched on accidentally. When the service disconnecting means cannot be locked, securely fasten a prominent warning device, such as a tag, to the service panel.
- C. Installation work and electrical wiring must be done by qualified person(s) in accordance with all applicable codes and standards, including fire-rated construction.
- D. Sufficient air is needed for proper combustion and exhausting of gases through the flue (chimney) of fuel-burning equipment to prevent back drafting. Follow the heating equipment manufacturer's guide lines and safety standards, such as those published by the National Fire Protection Association (NFPA) and the American Society for Heating, Refrigeration and Air Conditioning Engineers (ASHRAE), and the local code authorities.
- E. When cutting or drilling into wall or ceiling, do not damage electrical wiring or other hidden utilities.
- F. Ducted fans must always be vented to the outdoors.
- G. If this unit is to be installed over a tub or shower, it must be marked as appropriate for the application.
- H. **NEVER** - place a switch where it can be reached from a tub or a shower.

CAUTION - For general ventilating use only. Do not use to exhaust hazardous or explosive materials and vapors.

CAUTION- This unit has an unguarded impeller. Do not use in locations readily accessible to people or animals. This fan is intended for use facing an unoccupied space only.

Be sure your fan is properly installed. Your fan is designed to operate on 120 VAC 60 Hz.

Sharp edges are exposed during installation. Use gloves and other safety equipment to avoid accidents.

WARNING - To reduce the risk of fire or electric shock, do not use this fan with any solid state speed control.

IMPORTANT

This ventilator is designed to add thermostatically controlled power to existing systems of attic ventilation. It can be mounted behind many possible kinds of existing vents or louvers (Fig. 1). Metal louvers provide the least resistance to air flow and can usually be smaller than other types.

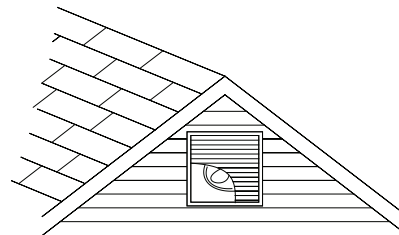

FIG. 1

With the power vent installed, at least 780 square inches of inlet area must be provided. This is achieved by installing 12, 8" x 16" intake vents, measuring 65 square inches each. The inlet is best at the opposite end of the house to provide air flow the full length of the attic (Fig. 2). If your home needs more intake air, we suggest Lomanco Cornice or Soffit vents.

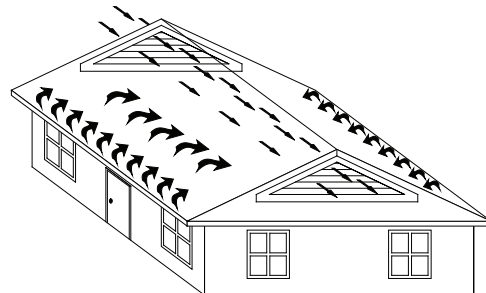

FIG. 2

OPERATION

Your ventilator will operate automatically as needed. The adjustable thermostat has been set at the factory to come on at 100° F., off at 85° F. The motor has been permanently lubricated and does not require additional lubrication.

INSTALLATION

Your ventilator was designed to make installation easy (Fig. 3). Normally you can just nail it to existing studs behind your louver. The mounting bracket may be

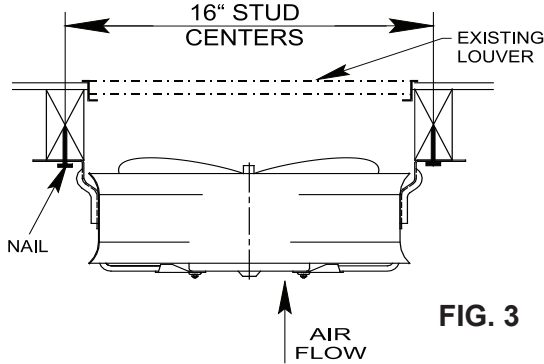

FIG. 3

installed either horizontally or vertically. If the studs are not correctly spaced on your home, 2x4 headers should be installed on 16" centers.

The thermostat should be located above the ventilator (in the warmest part of the air space) and away from the direct air stream.

The thermostat is a delicate instrument. Use screws instead of nails when fastening bracket to the house.

WIRING

Your Lomanco Power Ventilator **MUST** be wired as shown (Fig. 4). Make all connections inside the thermostat box.

Connect white (neutral) wire from a power supply to white wire on motor. Connect black (hot) wire from power supply to black wire on the thermostat and black wire on switch. The other black wire on the thermostat and

black wire on switch have been connected to the black wire on the motor at the factory, but should be checked to ensure a good tight connection. The ground wire should be connected to the screw in the bottom of the thermostat box.

WARNING! Turn off power before connecting power wires to ventilator. Your power feed wire should be 14 gauge or higher wire size (two wires plus ground). Take from thermostat box and bring to power distribution panel. Feed through bushing and connect to 15-amp circuit breaker.

- Black to circuit breaker;
- White to neutral base;
- Plain to ground base.

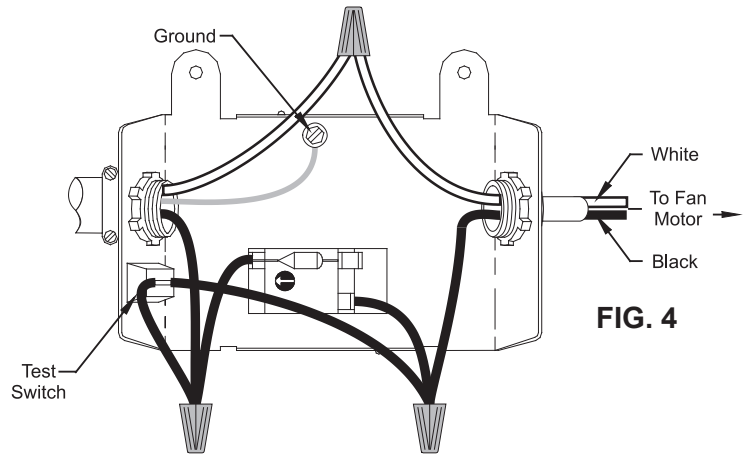

FIG. 4

Recheck your connections then turn the power on. You should now enjoy the advantages of a Power Ventilator, operating as the thermostat demands.

A test switch has been provided. To make sure your Lomanco Power Ventilator is operating properly, simply "PUSH TO TEST". Caution should be taken to ensure that no body parts come in contact with any of the vent's moving parts during this test. **NOTE: To control humidity in your attic, a humidistat is also available.**

- CSA-Certified



LIMITED WARRANTY

Lomanco, Inc. Warrants this product for five (5) years against any defects due to workmanship, parts or mechanical failure. For warranty service the defective part must be sent, freight prepaid to Lomanco Inc. P.O. Box 519, 2101 West Main Street, Jacksonville, Arkansas 72076. If the part is found to be defective it will be replaced with a new part at no charge and returned, freight prepaid. This warranty does not include replacement due to destructive storms or labor cost incurred in the removal of any defective part/product or installation of the new part/product. Online registration of the product at www.lomanco.com within ten (10) days of the initial installation of the product is a condition precedent to warranty coverage. **ANY IMPLIED WARRANTIES OF MERCHANTABILITY AND FITNESS FOR A PARTICULAR PURPOSE ARE ALSO LIMITED IN DURATION TO FIVE (5) YEARS. CONSEQUENTIAL DAMAGES TO PROPERTY RESULTING FROM A BREACH OF ANY WARRANTY MENTIONED HEREIN ARE EXPRESSLY EXCLUDED.** Some states do not allow limitations on how long an implied warranty lasts or do not allow exclusion or limitation of consequential damages, so the above limitation may not apply to you. The warranty gives you specific legal rights and you may also have other rights which vary from state to state.



ONLINE WARRANTY REGISTRATION

Please fill out the online form at lomanco.com to complete your warranty registration. If for any reason you are unable to register your product online please call 800-643-5596 and we will assist you. Purchase and install date information will be required.

DO'S AND DON'TS FOR ATTIC VENTILATION.

- DO** install all Exhaust Ventilation at the **SAME HEIGHT** within a common attic area. Installation of exhaust vents at more than one level on a roof allows the upper exhaust vent to wrongly pull air in from lower exhaust vent rather than from the soffit Intake Vents.
- DON'T** install exhaust vents at different heights.
- DON'T** install Ridge Vents down the hip.
- DO** install **ONLY ONE TYPE** of Exhaust Ventilation within a common attic area. Exhaust Vents pull air from the easiest Intake source. The use of two or more types of exhaust vents such as Power Vents with Roof Vents or Gable Vents with Ridge Vents or Roof Vents could make one of these vents act as intake instead of pulling air from the soffit vents.
- DON'T** mix different types of exhaust vents.
- DO** install a **BALANCED SYSTEM** of Intake and Exhaust Ventilation. 50% Intake and 50% Exhaust is a balanced system. Improper intake may lead to snow or rain infiltration into the exhaust vents.