

---

## RANGE HOOD MAKE-UP AIR KIT WITH DAMPER TRANSFORMER AND ADJUSTABLE STATIC PRESSURE SENSOR FOR MODELS MUA-06, MUA-08, MUA-10

### INTRODUCTION

The MUA-XX Make-up Air kit includes a 24 volt motorized damper, transformer, adjustable static pressure sensor, duct probe and 3/4" of 1/4" clear vinyl tubing along with mounting hardware. The MUA-XX is easy to install and designed to bring in outside air when exhaust fans such as a kitchen range hood exceed 400 CFM. The fully adjustable static pressure sensor allows the contractor to calibrate the makeup air requirement to meet code without bringing in excessive outside air. The MUA-XX safely equalizes negative pressure within the home envelope to prevent harmful gases and/or particulate matter that can be generated from appliances such as cook tops, water heaters or fireplaces. Multiple dampers can be daisy chained together for high volume applications ensuring optimal performance of exhaust fan operation.

### **WARNING!**

**Please observe the following instructions to prevent electrical shock, personal injury and the risk of fire or damage to equipment.**

1. Installation and electrical wiring must be done by a qualified installer in accordance with all applicable codes and standards.
2. The MUA-XX is not intended to provide combustion air for fuel-burning appliances nor should it be installed in such a manner.
3. When performing installation, service or cleaning, switch power off at the service panel.
4. When drilling into wall or ceiling, be careful not to damage electrical wiring or other hidden utilities.
5. The MUA-XX must be installed inside the home in a location protected from moisture.
6. The MUA-XX must be installed in an accessible location for inspection and service.
7. Use the MUA-XX only for its intended application.

### **CAUTION!**

1. Do not locate outside air inlet near hazardous materials or explosives.
2. The MUA-XX should not be installed to introduce outside air from crawlspaces, garages, attics, adjacent dwelling units, or any other location other than directly from the outdoors.
3. The outside air damper, duct work and any filters should be inspected and maintained on a regular basis.
4. Insulate the outside air duct and damper to prevent condensation in cold weather. A vapor barrier on both sides of insulation is recommended.

### INSTALLATION

#### **Outside Air Intake Location**

1. Proper sizing and location of the outside air intake is critical in ensuring that the damper can safely and reliably provide fresh air into the home.
2. Outside air intake must be located a minimum of 10' from combustion appliance vents, chimneys, plumbing stacks as well as kitchen and bathroom exhaust vents. Local codes may have additional requirements which also may apply.
3. Outside air intake must be installed high enough above grade to prevent blockage from snow or other debris.

#### **Outside Air Intake Protection**

1. Outside air inlet wall caps should include a protective bird screen to keep out animals and outside debris. Clean screen often and do not remove.
2. Outside air inlet should meet local code for the protection of openings in exterior walls, including steps to prevent moisture intrusion around opening.

## TYPICAL OUTSIDE AIR DAMPER INSTALLATIONS

Installation of the outside air damper and duct work can vary based on the location of the HVAC system or where the damper and outside air duct is connected directly to a ceiling, floor, or wall register. Always comply with local code.

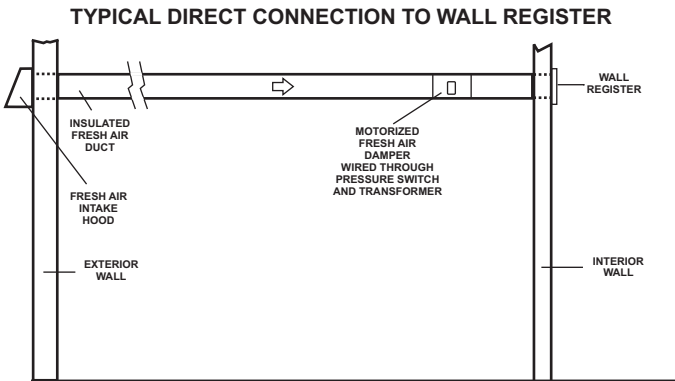
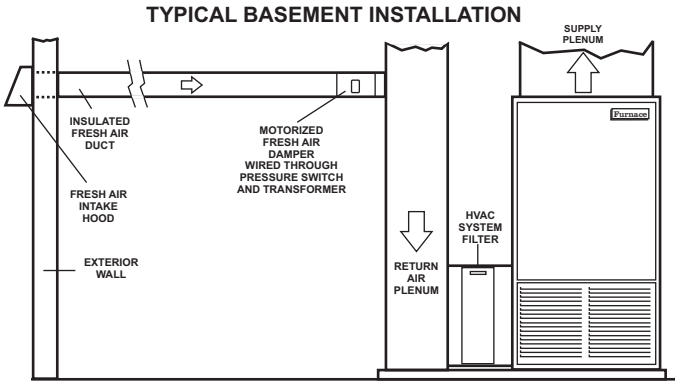

## DAMPER INSTALLATION

Install the outside air damper as shown. The damper has a 24 volt, 2 wire actuator that powers open and spring returns closed. Make sure the damper blade is in a vertical position when closed. The damper also has a minimum position adjustment screw to assist in balancing the inside and outside air pressure when the range hood exhaust is at high speed.

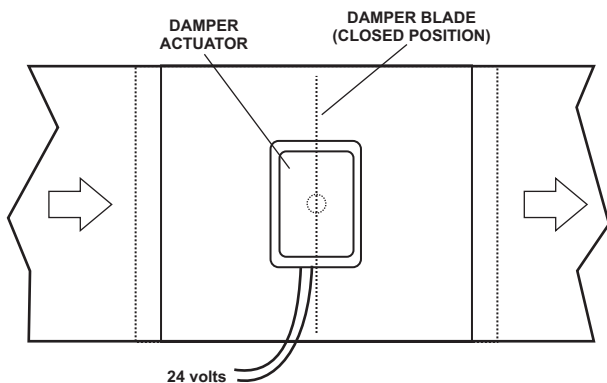

## INSTALLING MULTIPLE DAMPERS

Some applications may require more than one damper to balance the system. However, the transformer provided in the MUA-XX kit is rated at 20VA and each damper has a rating of 10VA. If more than two dampers are used, an additional transformer and relay may be required.

## INSTALLING THE PRESSURE SENSOR

The ZPA-SPS Pressure Sensor is designed to activate when the static pressure exceeds the pressure sensor setpoint. The sensor is fully adjustable from 0.08" to 1.20" W.C. The factory default setting is 0.08" W.C. (20 Pa).

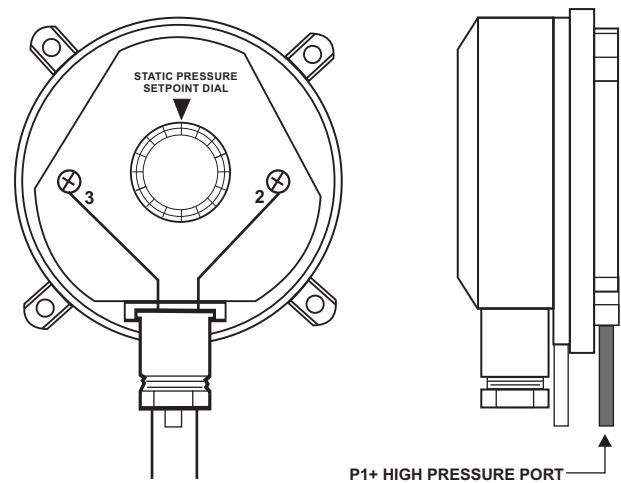

The Pressure Sensor should be mounted in a vertical position in an area accessible for wiring to the fresh air damper and attachment to the pressure tubing and probe.

## MOUNTING THE PRESSURE SENSOR PROBE

The probe must be installed between the range hood damper and the wall cap, roof cap, in-line blower or external blower. Mount the probe as close to the hood outlet as possible but make sure it does not obstruct the hood damper operation. Attach the pressure tubing to the P1+ High Pressure Port on the pressure sensor and to the probe. Trim excess tubing as necessary. Note that the probe has an arrow on the mounting flange that needs to be aligned in the direction of air flow.

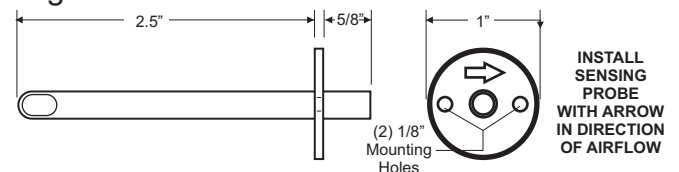

# INSTALLATION EXAMPLES

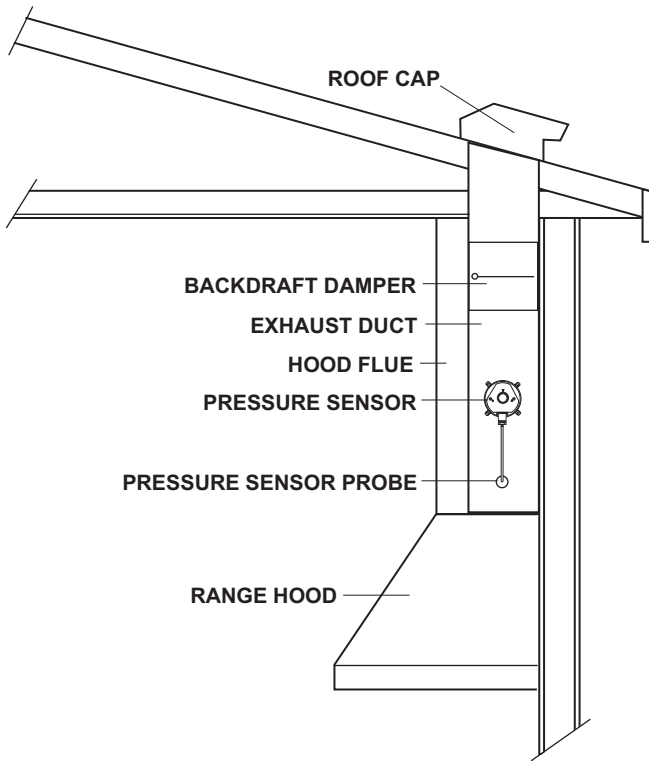

**INTERNAL BLOWER WITH ROOF VENT**

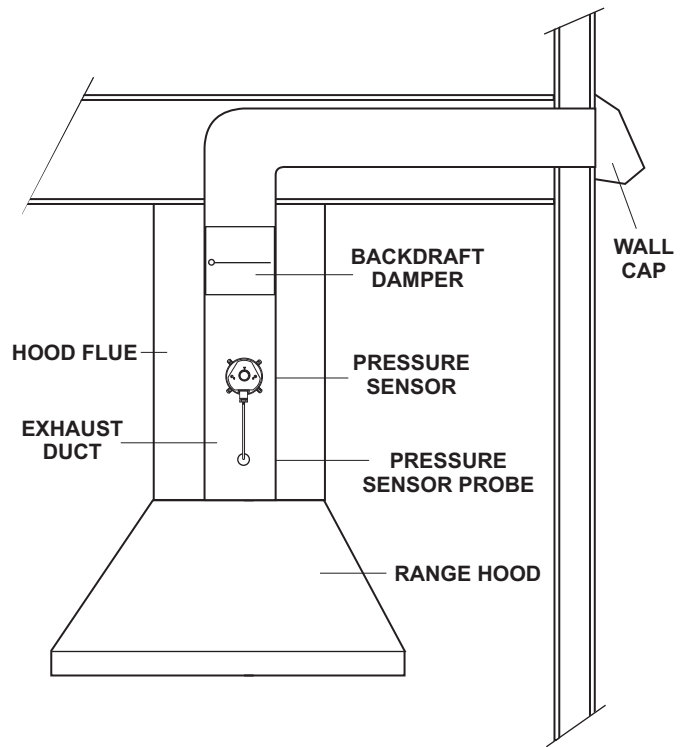

**INTERNAL BLOWER WITH WALL VENT**

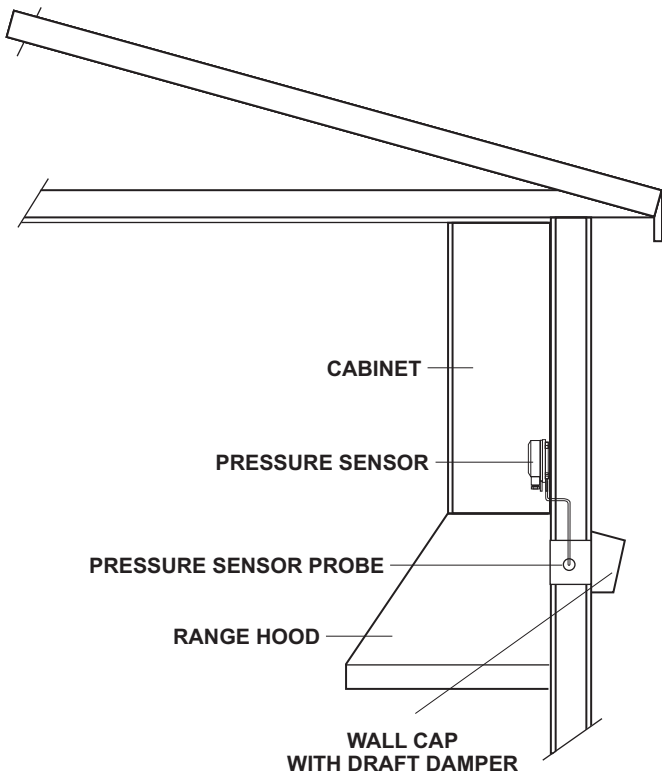

**INTERNAL BLOWER WITH WALL VENT**

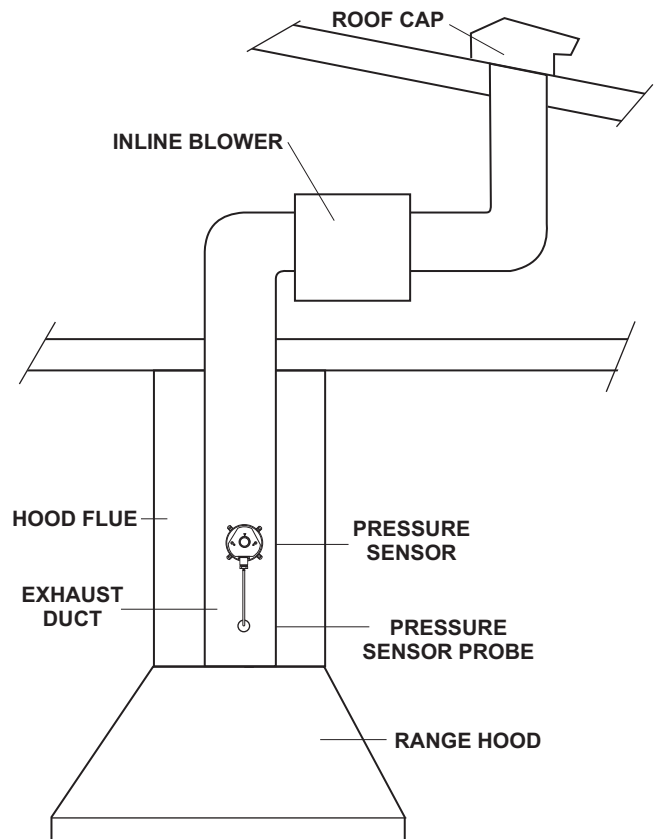

**EXTERNAL BLOWER WITH ROOF VENT**

## WIRING THE STATIC PRESSURE SENSOR, TRANSFORMER AND FRESH AIR DAMPER

1. Mount the transformer in an area accessible to 120 volts AC.
2. Transformer and wiring must be installed in accordance with all electrical standards and codes.
3. Use 18 gauge, solid copper thermostat wire for all 24 volt connections.

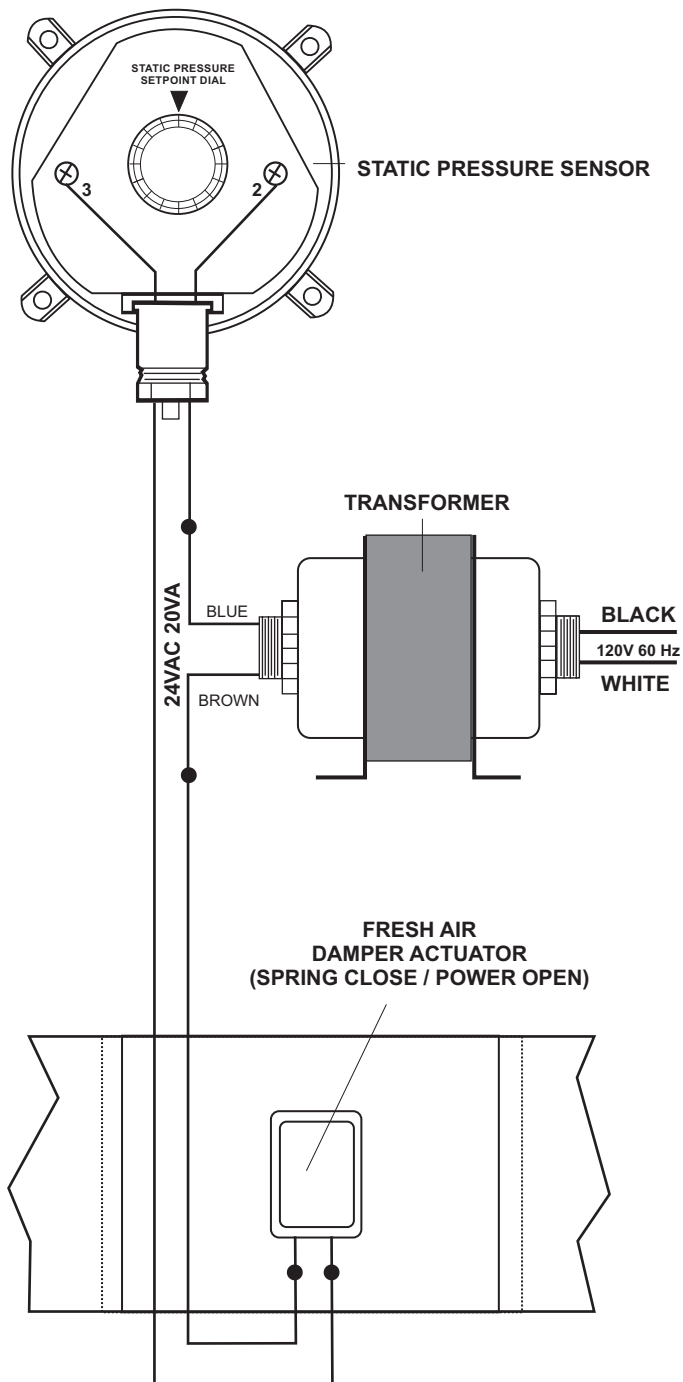

## SYSTEM TEST

Once installation and wiring are complete, turn on main power to the system transformer. Turn the range hood to high speed and confirm that the fresh air damper opens. Turn the range hood off and confirm that damper closes. Make sure that all draft dampers are working properly to prevent false tripping of the static pressure sensor due to backdrafts.

A qualified HVAC contractor should also ensure the proper operation and venting of all combustion equipment in the home.

## MUA-XX KIT SPECIFICATIONS

### ZPA-SPS STATIC PRESSURE SENSOR

Pressure Range:	0.08" to 1.20" W.C.
Operating Temperature:	-40° to 190°F
Maximum Switching Current:	1 Amp @ 24VAC
Maximum Pressure:	40" W.C.
Terminal Designations:	2 & 3
Pressure Connection:	1/4" I.D. x 36" clear vinyl flex hose (Included)
Pressure Sensor Probe:	1/4" O.D. x 3-3/4" one piece ABS with mounting flange (Included)

### D-XX-PO FRESH AIR DAMPER

Sizes:	6" - D-06-PO 8" - D-08-PO 10" - D-10-PO
Construction:	24 gauge galvanized steel shell 20 gauge steel blade 5/16" aluminum shaft Nylon bushings Air tight blade seals Minimum position adjustment
Electrical:	24 Volt, 10 VA, powered open, spring return closed actuator Impedance protected with no end switches

### TR-20-DH TRANSFORMER

Input:	120 Vac
Output:	24 Vac
VA Rating:	20 VA
Frequency:	50/60Hz
Circuit Protection:	Internally Protected
Configuration:	Enclosed Split Bobbin Design with Steel End Bells
Mountings:	Slotted Foot Mounts & Threaded Flange Hubs
Connections:	UL 1015 Insulated 18 AWG primary and secondary 7.5" lead wires
Agency Approvals:	UL 1585 / UL 5085-1 / UL 5085-3 Listed for USA & Canada. Class 2, Class 3 Transformer