

ZP3-HCMS Installation and Operation Instructions

(Versions 301) 2 Heat / 2 Cool - Auto Changeover

First Call Priority - Time Share

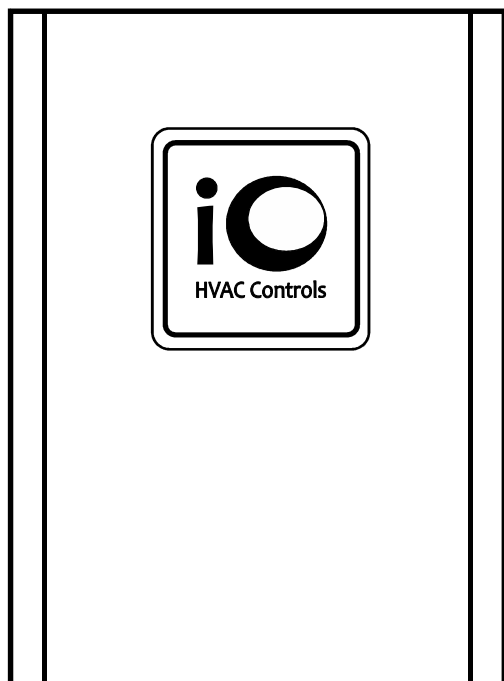

Sequence of Operation:

The ZP3-HCMS is a residential / light commercial zone control system that allows a single HVAC unit to have up to three separate zones. Each zone is controlled by its own space thermostat and motorized zone damper. If a zone thermostat calls for heating or cooling, the zones not calling will have their dampers powered closed, and the zone calling will have its damper opened. The heating or cooling equipment will also be brought on at the same time. When the zone calling is satisfied, the heating or cooling equipment turns off. If one zone calls for heating and another zone calls for cooling, the first zone to call receives priority. When the first call is satisfied, the system will changeover and take care of the opposite call. If a zone being served (heating or cooling) has not been satisfied within 20 minutes while an opposite call is taking place, the system will changeover. When the zone is satisfied or 20 minutes has elapsed, the system will again changeover if an opposite call exists. This is referred to as Auto Changeover - First Call Priority - Time Share. In the event of a tie, cooling will receive priority.

High and Low Limit Protection:

The ZPA-DTS Discharge Temperature Sensor should be mounted on the discharge air plenum of the HVAC unit and wired to the DA terminals on the panel. The sensor is used for both high and low limit protection. The high limit setting can be adjusted using the two slide switches located on the panel. (See switch location and settings on page 2) The low limit is fixed at 45° F. When the discharge air temperature rises above the high limit setting or falls below the low limit setting, the panel will cycle the equipment off while the fan continues to run. The LIMIT LED blinks when high or low limit is reached.

Ventilation Mode:

Zone ventilation is established by the individual zone thermostat fan setting. Any thermostat set in the fan AUTO mode will not receive ventilation air when there are no heating or cooling calls. Any thermostat set in the fan ON mode will receive ventilation air whenever there are no heating or cooling calls.

Power Requirements:

The ZP3-HCMS panel requires a separate 24 VAC transformer to power the panel, thermostats and zone dampers. The VA rating of the transformer will be dependent upon the type and total number of zone dampers being used. Refer to specific damper actuator specifications when calculating the total transformer VA requirement. Any single zone can have multiple dampers wired in parallel providing the total VA rating of the dampers does not exceed 30 VA. If the total number of dampers on a single zone exceed 30 VA, a relay should be used with an additional, properly sized transformer.

Wiring:

All wiring should be conventional 18 gauge thermostat wire. Thermostats and zone dampers may be located up to 300 feet from the ZP3-HCMS panel.

ZP3-HCMS Installation and Operation Instructions

(Versions 301) 2 Heat / 2 Cool - Auto Changeover

First Call Priority - Time Share

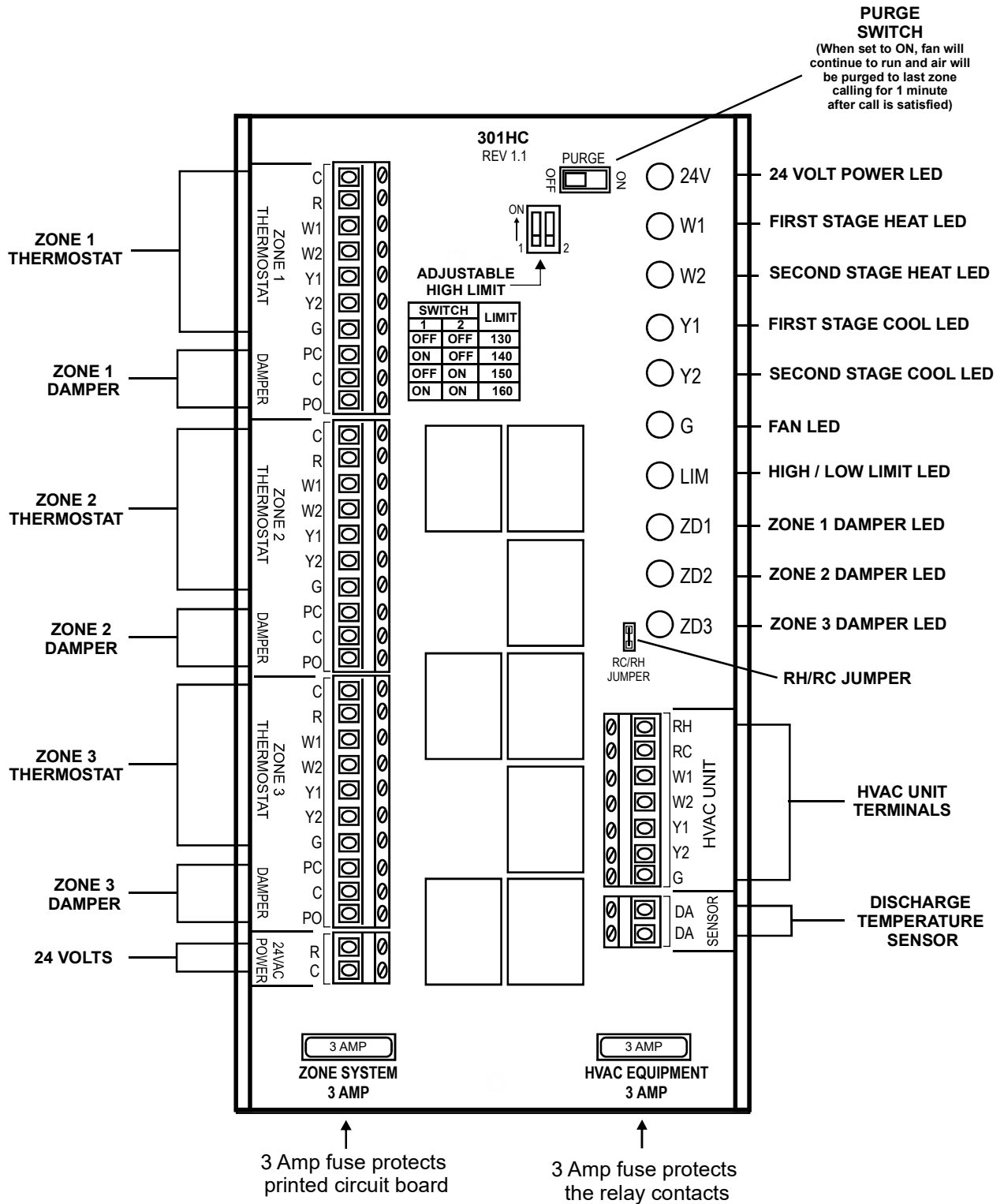

ZP3-HCMS Installation and Operation Instructions

(Versions 301) 2 Heat / 2 Cool - Auto Changeover

First Call Priority - Time Share

Installation

Mounting the Panel:

Carefully remove the ZP3-HCMS panel and cover from the shipping carton. Slide the PC board out of the snap track base and mount the base to a flat surface either on or near the HVAC indoor unit in an area that will facilitate easy access for wiring. Reinstall the PC board by carefully centering it over the base and snapping it back into the track grooves.

Wiring the Zone Thermostats and Dampers:

Refer to the logic panel wiring diagram. Wire zone 1 thermostat and its associated damper to the ZONE 1 terminals on the logic panel. Wire zone 2 and 3 thermostats and dampers in the same manner.

Wiring the HVAC Equipment:

Wire the HVAC unit to the panel terminals. Do not wire the equipment common to the ZP3-HCMS panel.

Installing and Wiring the ZPA-DTS Discharge Temperature Sensor:

Drill a 15/32" hole in the middle of the main discharge air plenum approximately 18" to 30" from the heat pump electric strip heater or the furnace heat exchanger in a fossil fuel application. Slide the discharge air probe into the hole and use two self-tapping sheet metal screws to secure the base to the plenum. Use conventional 18-2 thermostat wire and wire nuts to attach the sensor leads. Replace the cover with the wire nut connections inside. Strip 1/8" insulation off of each wire at the other end and and the wires to the screw terminals marked DA on the panel.

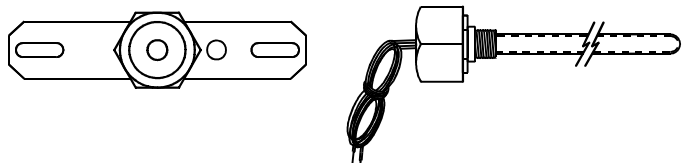

Wiring the Transformer:

Wire a separate 24 Volt transformer of the proper VA to the logic panel terminals marked (R) and (C). Do not power the panel up until wiring is completed.

Test, Check and Startup:

1. Verify that all component wires have been connected to the proper terminals and are secure.
2. Disconnect the HVAC equipment (R) terminal wire at the panel and apply 24 Volts to panel.
3. Take a jumper wire and momentarily short the DA terminals. This will put the panel's time delays in "speed up" mode.
4. Place the zone thermostats in the OFF position.
5. The panel accepts 2-wire (power close / spring open) or 3-wire (power open / power close) zone dampers. 2-wire dampers should be wired to the (C) and (PC) terminals.
6. Place zone one thermostat in the fan ON mode. ZD1 LED will remain on and ZD2 and ZD3 LED will go out. The (G) FAN LED will come on.
7. Confirm that zone one damper is in the open position and zone two and three dampers are closed.
8. Leave zone one thermostat in fan ON and place zone two thermostat in the fan ON mode. ZD2 LED will come on.
9. Confirm that both zone one and zone two dampers are in the open position and zone three damper is closed.
10. Leave zone one and zone two thermostats in Fan ON and place zone three thermostat in the fan ON mode. ZD3 LED will come on. Confirm that all zone dampers are in the open position.
11. Place all zone thermostats in the Auto fan mode.
12. Remove 24 Volts to the panel and reconnect the HVAC ® wire.
10. When 24 Volts is applied again to the panel, the internal time delays will be activated.
11. Place zone thermostats in proper mode of operation.
12. Confirm that the LIMIT LED is ON. If not, check LIMIT wiring. If the system goes out on high or low limit, the LIMIT LED will blink.

ZP3-HCMS Installation and Operation Instructions

(Versions 301) 2 Heat / 2 Cool - Auto Changeover

First Call Priority - Time Share

Specifications

Panel Dimensions:

Height: 8.0 Inches
 Width: 6.0 Inches
 Depth: 1.375 Inches

Mounting:

Snap Track with 2 back plate screws

Operating Temperature Rating:

-40° F to 150° F

Operating Humidity:

5% to 90% RH non-condensing

Wiring:

18-gauge wire for all equipment and system connections

Time Delays:

3 minutes minimum off between cooling calls
 3 minutes minimum off on low limit
 20 minute time share
 Purge ON = 1 minute

Thermostats:

Single or multi-stage heat / cool
 Programmable or non-programmable
 Auto or manual changeover

Terminal Designations

Thermostats:

C 24Vac (Common)
 R 24Vac (Hot)
 W1 First Stage Heat
 W2 Second Stage Heat
 Y1 First Stage Cool
 Y2 Second Stage Cool
 G Fan

Dampers:

PC₂ Powered Closed
 C₁ Common
 PO₃ Powered Open

High / Low Limit Sensor

DA Land to ZPA-DTS
 DA Land to ZPA-DTS

HVAC Unit:

RH 24Vac Heating Transformer
 RC 24Vac Cooling Transformer
 W1 First Stage Heat
 W2 Second Stage Heat
 Y1 First Stage Cool
 Y2 Second Stage Cool
 G Fan

Panel Power:

R 24Vac (Hot)
 C 24Vac (Common)

