



MODEL TR130

(Energy Recovery Ventilators -ERV)



Specifications

Ventilation Type: Static Plate, Heat and Humidity Transfer				
Typical Airflow Range: 50-140 CFM				
Unit may be mounted in any orientation				
Number Motors: One, 0.1 hp				
V	Hz	Phase	Input Watts	FLA
120	60	Single	102@130CFM	1.3
Control Voltage: 24 VAC transformer / relay package with switched dry contacts				
Filters: MERV 8, spun polyester media. 10-1/2" x 10-1/2" x 1"				
Weight: 48 lbs (unit), 60 lbs (in carton)				
Shipping Dimensions: 32" L x 22" W x 18" H				

Core Performance

Airflow CFM	ESP in H ₂ O	Temp EFF%	Total EFF% Winter*	Total EFF% Summer*
79	0.60	78	73	60
104	0.50	75	69	55
126	0.40	72	66	50
137	0.30	71	64	48
153	0.20	68	61	45
165	0.10	67	59	43

* Contact Factory for HVI certification report for complete certified rating.

Dimensions

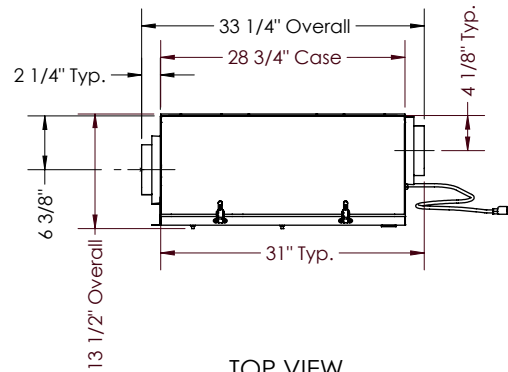

ABBREVIATIONS
 EA: Exhaust Air to outside
 OA: Outside Air intake
 RA: Room Air to be exhausted
 FA: Fresh Air to inside

INSTALLATION ORIENTATION
 Unit may be installed in any orientation.

NOTE
 1. UNLESS OTHERWISE SPECIFIED, DIMENSIONS ARE ROUNDED TO THE NEAREST EIGHTH OF AN INCH.

