

HEPA TOWER Specs & Information

DESCRIPTION

Medical grade HEPA filtration is extremely effective at removing particles the human eye can't see. In fact, tests show medical grade HEPA filters are effective down to .01 microns. Why is that so important? Because pathogens like COVID-19 can float in the air for hours after an infected person occupies the space. Scrubbing the air with medical grade HEPA filtration is a highly effective way to reduce risks.

SPECIFICATIONS

Dimensions:	77 3/8" High x 27" Wide x 20 3/8" Deep
Weight:	172 lbs
Electrical:	120VAC, 60 Hz, Single Phase, 2.5A
Tested Airflow:	62 / 1300 CFM (Low / High)
Tested Power:	10 / 272 Watts (Low / High)
Tested Noise*:	42 / 59 dBa (Low / High)
Controls:	Low Voltage, Digital Touch Controller, Optional Wireless Remote.
Speed Settings:	10
Timer:	12 Hours, in increments of 1 Hour.
Warranty:	3 years mechanical & structural parts, 1 year control parts.



* Tested at 45° and 1 meter from source

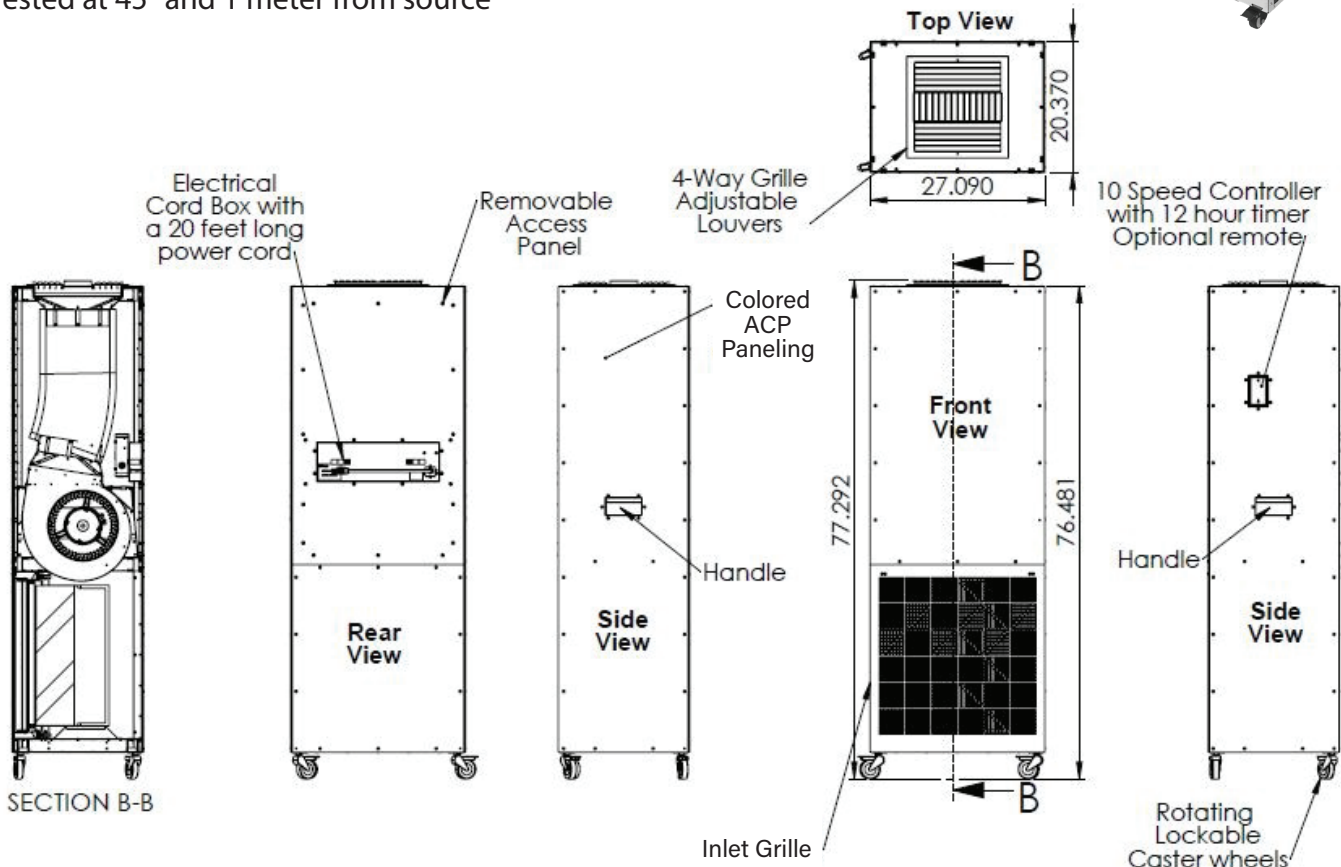

MAINTENANCE

- Replace The Tower's Pre-Filter every 2-3 Months.
Actual Size: 23 3/8" x 23 3/8" x 1 3/4" (or 3/4") MERV11 Filter.
- Check HEPA Filter airflow and visually check Filter surface (do not touch) to determine when needing replacement. **Estimate 2-3 years depending on conditions.**
Actual Size: 23 3/8" x 23 3/8" x 12" (H13) HEPA-Filter.

NOTE: Consider a used HEPA Filter "contaminated" and discard with care!

- Clean exterior paneling / wheels using mild soap and a clean cloth.
- Visually inspect the unit, wheels, paneling, air-inlet grille and air-exit louver for proper functioning and fit.

