

Inline Centrifugal Fans for Round Duct

the ultimate in quality, quiet performance and cost efficiency



FR Series

FX Series

FKD Series



Fantech FR Series

Versatility and Value

Fantech's versatile FR Series fans feature a plastic housing constructed of UL-recognized, UV-protected thermoplastic resin. This tough protective shell allows the fan to be mounted in outdoor and wet locations.* Ideal for multiple point exhaust, dual bathroom exhaust, or new room additions, Fantech's FR Series fans are caulked at the motor screws, the wiring cables and along the seams of the fan to prevent moisture from entering the housing. Fantech's FR Series fans have long been the choice of residential builders and remodelers but now can be used for commercial projects with our recent UL commercial applications rating.

Easy to install

Loaded with features

- Prewired and supplied with a mounting bracket for easy installation
- Available singularly with bracket or in a variety of kits for specific applications. Each kit includes the appropriate fan and accessories
- Tested and approved by UL, CSA, or equals
- Approved for residential and commercial applications and for wet locations
- Suitable for airstream temperatures up to 140° F
- Easy connection using external wiring box with waterproof gasket
- 122-649 CFM
- 4" to 10" duct diameters
- 100% speed controllable
- Five-year factory warranty

Kits are available for the following applications:

- Dryer Boosting Kit (DBF 110) for boosting clothes dryer installations with extended duct runs
- Regular Kits (REG 100 and REG 140) for single point exhaust applications
- Deluxe Kits (DLX 110, DLX 150, and DLX 200) designed for dual point exhaust applications
- Vent Light Kits (REG 100L, DLX 150L) for single and dual vent light exhaust applications

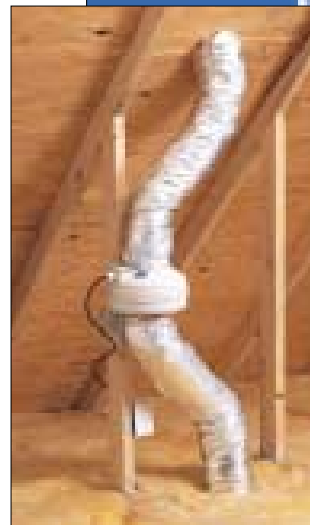
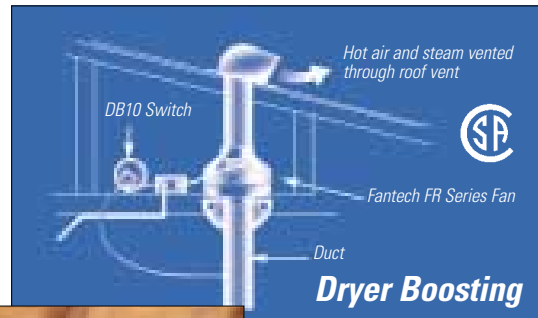

Typical attic installation

Two Baths... One Solution!

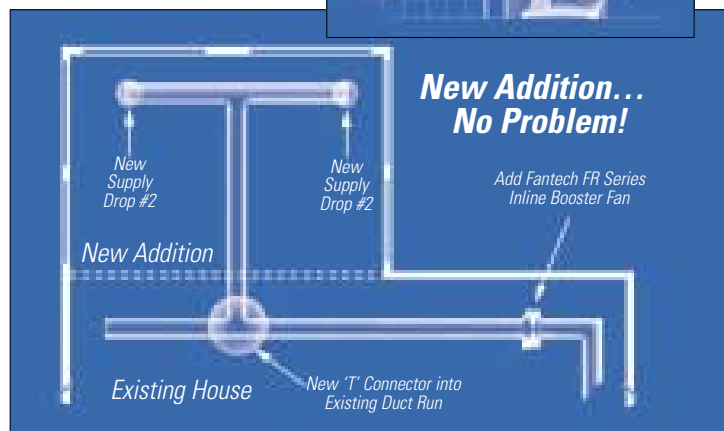
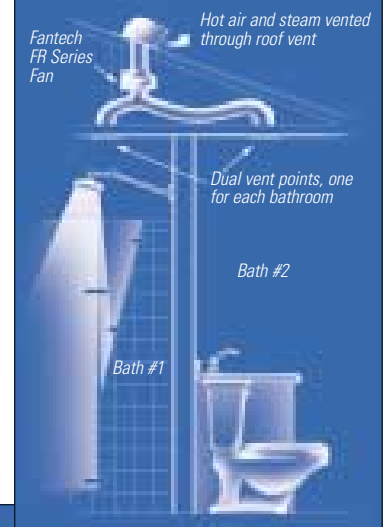

* The FR Series is not manufactured to operate with water running through the motor compartment, or to be used in applications where the fan would be buried underground. A UL-recognized waterproof conduit should be used for all outdoor applications to prevent moisture entry via knockout in wiring box.

FR Kits

Pictured from left to right: DBF110 – Dryer Boosting Kit; DLX150 – Dual Point Ventilation Kit; REG100L – Single Vent Light Kit. Additional kits (not pictured) are available.



DBF110



DLX150



REG100L

Specifications

FR Series Dimensional Data

model	†A1	A2	C	D	E	F
FR 100	4	5	9½	6½	7⁄8	7⁄8
FR 110	4	5	9½	6½	7⁄8	7⁄8
FR 125	—	5	9½	6½	7⁄8	—
FR 140	6	6¼	11¾	57⁄8	1	7⁄8
FR 150	6	6¼	11¾	57⁄8	1	7⁄8
FR 160	6	6¼	11¾	63⁄8	1	7⁄8
FR 200	8	10	13¼	6¼	1½	1½
FR 225	8	10	13¼	6¼	1½	1½
FR 250	—	10	13¼	6¼	1½	—

All dimensions in inches. † Duct connections are 1/8" smaller than duct size.

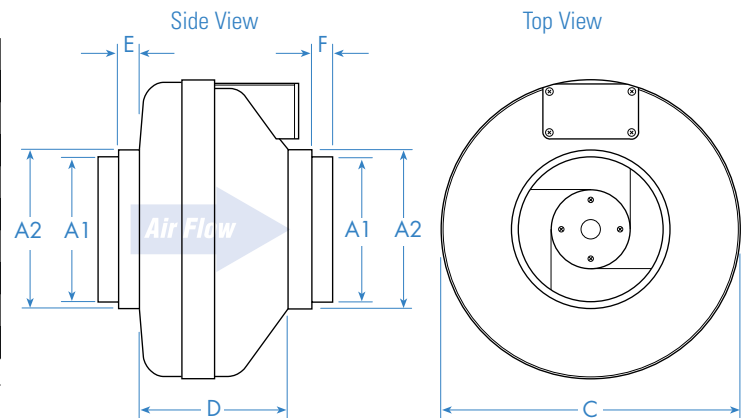

FR Series Air Performance Graphs

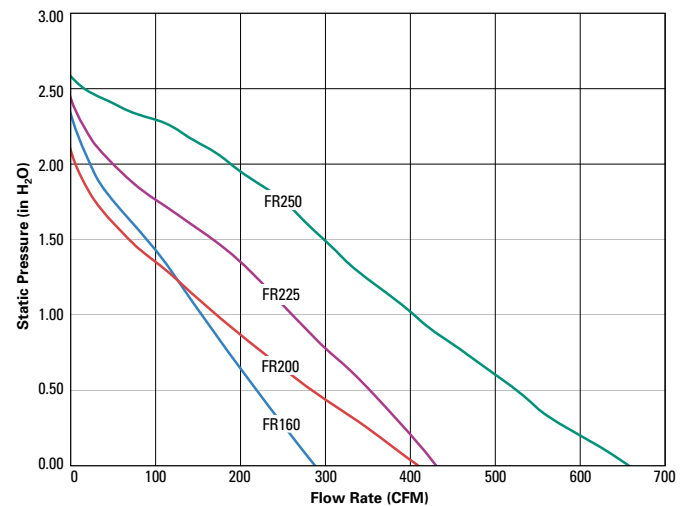
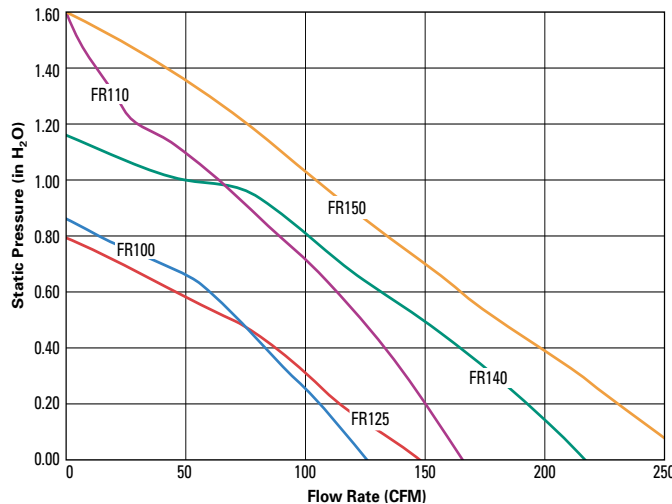

FR Series Performance Data

Fan Model	Energy Star	RPM	Volts	Rated Watts	Wattage Range	Max. Amps	Static Pressure in Inches W.G.							Max. Ps	Duct Dia.
							0"	.2"	.4"	.6"	.8"	1.0"	1.5"		
FR 100	√	2900	115	19	13 – 19	0.18	122	100	78	55	15	—	—	0.87"	4"
FR 110	—	2900	115	80	62 – 80	0.72	167	150	133	113	88	63	4	1.60"	4"
FR 125	√	2950	115	18	15 – 18	0.18	148	120	88	47	—	—	—	0.79"	5"
FR 140	√	2850	115	61	47 – 62	0.53	214	190	162	132	99	46	—	1.15"	6"
FR 150	√	2750	120	71	54 – 72	0.67	263	230	198	167	136	106	17	1.58"	6"
FR 160	—	2750	115	129	103 – 130	1.14	289	260	233	206	179	154	89	2.32"	6"
FR 200	√	2750	115	122	106 – 128	1.11	408	360	308	259	213	173	72	2.14"	8"
FR 225	√	3100	115	137	111 – 152	1.35	429	400	366	332	297	260	168	2.48"	8"
FR 250	—	2850	115	241	146 – 248	2.40	649	600	553	506	454	403	294	2.58"	10"

FR Series performance is shown with ducted outlet. Per HVI's Certified Ratings Program, charted air flow performance has been derated by a factor based on actual test results and the certified rate at .2 inches WG.



Fantech FX Series

From Residential to Commercial

The Fantech FX Series' galvanized steel housing makes these fans ideal for various commercial code and residential applications. Home uses include range hood exhaust, duct boosting, bathroom exhaust and dryer boosting. Office applications include intake, exhaust, filtration, return or makeup air systems that require mounting versatility, high efficiency, low sound levels, and ease of service.

Fantech FX Series fans are a snap to install. Prewired and supplied with a mounting bracket, they can be mounted at any angle in any point along the ductwork. Straight-through airflow design also helps simplify installation. FX Series fans are designed to work with standard dimensions of spiral duct, eliminating the need for transition pieces.

Hard working. Long lasting. Here's why:

- Galvanized steel housing features baked powdercoat finish, perfect for commercial code applications
- Powered by external rotor motorized impeller for excellent heat dissipation, even at low RPM
- Tested and approved by UL, CSA, or equals
- Suitable for airstream temperatures up to 140° F
- 4" to 12" circular duct diameters
- Airflow from 117-801 CFM
- External rotor motor, Class B insulation for long and maintenance-free operation
- Automatic reset thermal overload protection
- Permanently lubricated sealed ball bearings
- True airfoil backward curved impeller
- External wiring box for ease of connection
- 100% speed controllable
- Five-year factory warranty

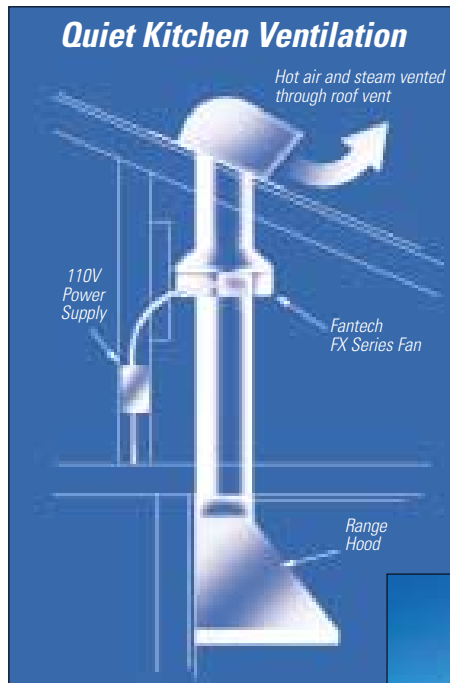

Fantech external rotor motor

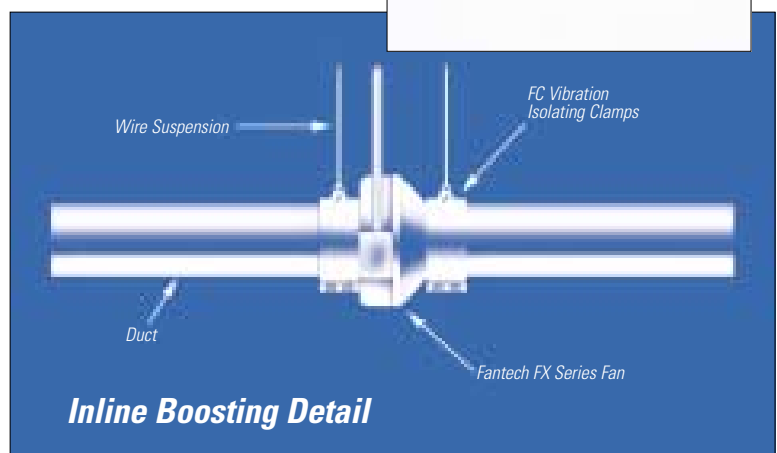

Inline Boosting Detail

FX Kits

DBF4XL – Dryer Boosting fan kit. The perfect solution to dryer blues. For applications when an extended duct length is required.



Specifications

FX Series Dimensional Data

model	↑A	C	D	E	F
FX 4	4	8	5½	7⁄8	7⁄8
FX 4XL	4	9½	5½	7⁄8	¾
FX 5	5	8	5¼	7⁄8	7⁄8
FX 5XL	5	9½	5	7⁄8	1
FX 6	6	11½	6	¾	7⁄8
FX 6XL	6	13¼	6½	1	¾
FX 8	8	13¼	6¼	1	7⁄8
FX 8XL	8	13¼	6¼	1	7⁄8
FX 10	10	13¼	6¼	1	1¼
FX 10XL	10	13¼	6¼	1	1¼
FX 12	12	16	8¼	1	1¼
FX 12XL	12	16	8¼	1	1¼

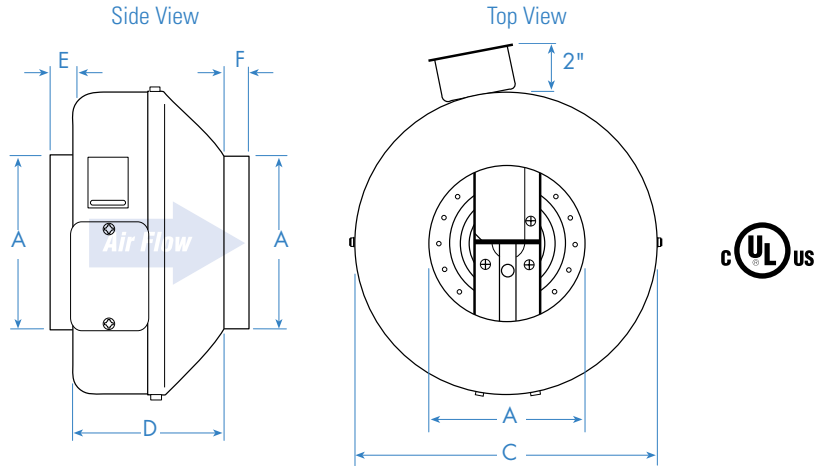

All dimensions in inches. † Duct connections are 1/8" smaller than duct size.

FX Series Air Performance Graphs

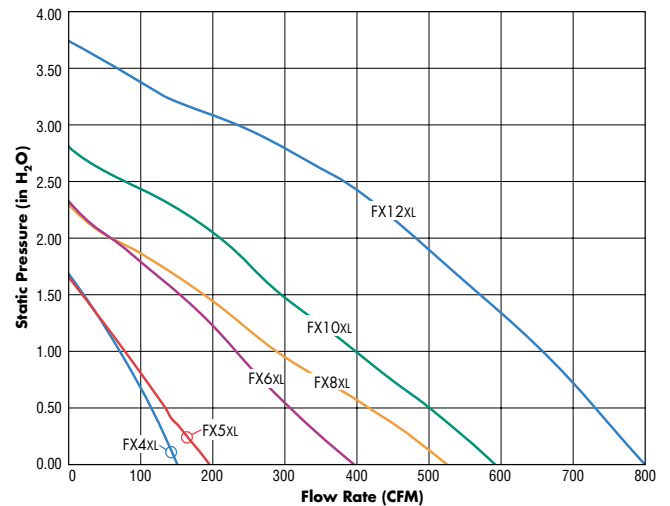
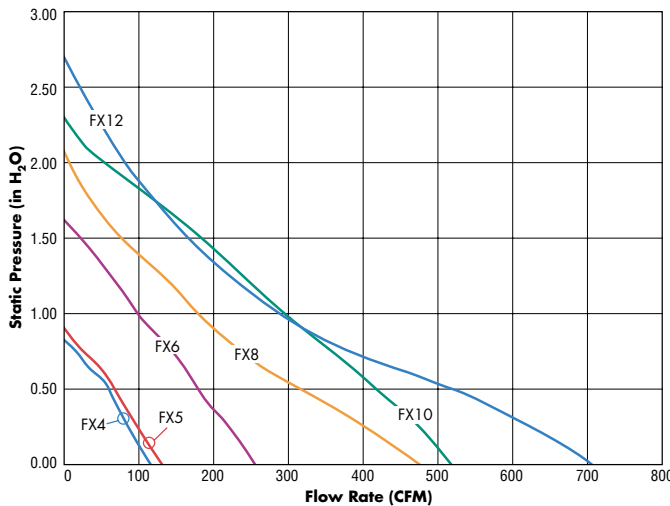

FX Series Performance Data (For sound performance data refer to publication #FX-0799)

Fan Model	RPM	Volts	Max. Watts	Max. Amps	Static Pressure in Inches W.G.										Max. Ps	Duct Dia.
					0"	.125"	.25"	.375"	.5"	.75"	1.0"	1.25"	1.5"			
FX 4	2950	115	19	0.17	117	101	86	72	58	—	—	—	—	0.81"	4"	
FX 4XL	2800	115	83	0.73	148	139	130	120	111	90	68	42	—	1.65"	4"	
FX 5	2950	115	19	0.17	132	115	98	81	65	—	—	—	—	0.89"	5"	
FX 5XL	2650	115	87	0.76	191	175	161	146	131	102	75	45	—	1.61"	5"	
FX 6	2700	115	84	0.74	257	241	221	197	178	143	99	59	—	1.60"	6"	
FX 6XL	2950	115	147	1.26	392	368	346	326	305	263	228	191	150	2.27"	6"	
FX 8	2600	115	116	1.02	481	444	403	361	319	237	177	130	76	2.04"	8"	
FX 8XL	2950	115	152	1.31	521	496	469	440	411	345	282	231	180	2.29"	8"	
FX 10	3000	115	147	1.27	521	499	475	448	418	357	293	234	176	2.28"	10"	
FX 10XL	3000	115	242	2.11	590	565	541	519	496	442	394	339	290	2.79"	10"	
FX 12	2450	115	196	1.70	711	675	627	576	521	382	284	220	166	2.65"	12"	
FX 12XL	3250	115	373	3.21	801	783	765	747	729	692	655	611	566	3.69"	12"	



Fantech, Inc. certifies that the FX Series shown herein is licensed to bear the AMCA Seal. The ratings shown are based on tests and procedures performed in accordance with AMCA Publication 211 and AMCA Publication 311 and comply with the requirements of the AMCA Certified Ratings Program.

Performance shown is for installation type D - Ducted inlet, Ducted outlet. Speed (RPM) shown is nominal. Performance is based on actual speed of test. Performance ratings do not include the effects of appurtenances in the airstream.

Fantech FKD Series

Inline Mixed Flow Duct Fans

With Fantech's FKD Series fans, "going with the flow" has never been easier. These fans are specifically designed to bridge the transition between centrifugal and axial by combining the high flow of axial designs with the higher pressure, non-overloading characteristics of backward curved impellers. Fantech's "The Straight Way" inline designs minimize system losses while being extremely compact.

The round inline design keeps air moving in ductwork sized from 8" to 20". 100% speed controllability gives extreme flexibility where there is need for varying airflow.

The lightweight, compact design FKD Series fans mount at any angle, at any point along the ductwork.

A balancing act that's easy to perform

With FKD Series fans, system balancing is achieved by measuring the system flow or pressure and adjusting the fan performance by "dialing in" or setting the fan speed using inexpensive solid state speed controls, transformers or VFDs. Direct drive eliminates the need for continuous belt alignment, tension adjustment and ongoing maintenance.



Fans pictured: Top—FKD12XL; Left—FKD10; and Bottom—FKD12S.



FYI:

FKD's performance features:

- Galvanized steel housing features baked powdercoat finish
- External rotor motor with built-in thermal overload protection and automatic reset
- Tested and approved by UL and CSA (or equals)
- Suitable for airstream temperatures up to 140° F
- Permanently lubricated sealed ball bearings
- 100% speed controllable for highly efficient and economical airflow
- Airflow up to 6291 CFM
- Terminal box with prewired electrical strip
- Mixed flow impeller
- Excellent heat dissipation to ensure long motor life
- Three-year warranty



Fantech's FKD external rotor motor – built to last.

Transparent view of a FKD 10

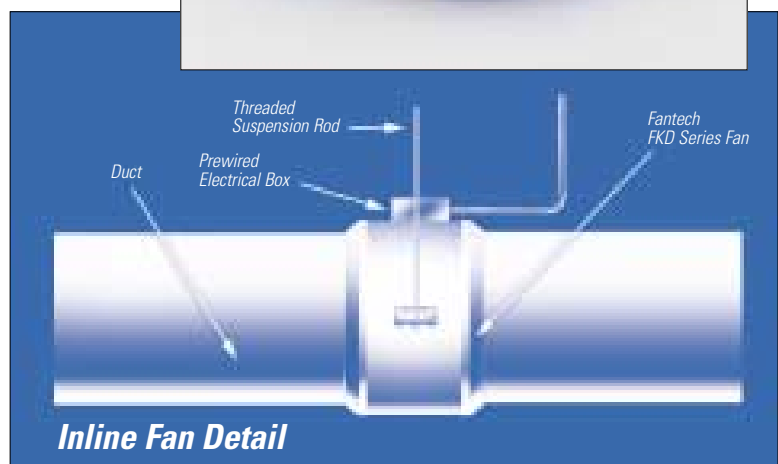

Specifications

FKD Series Dimensional Data

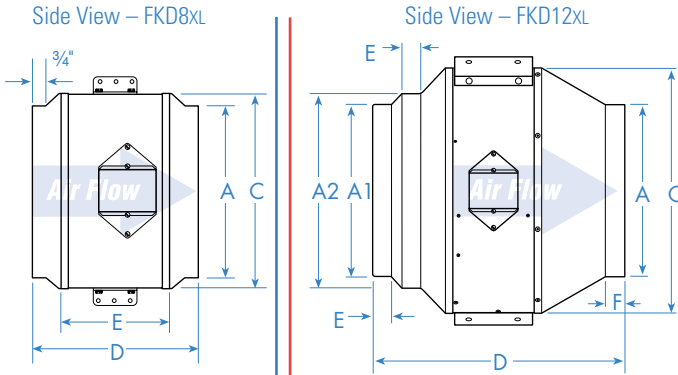

model	A	C	D	E
FKD 8XL	8	12½	15½	7
FKD 10	10	12½	12½	7
FKD 10XL	10	14	15	8
FKD 12s	12	12½	10	7
FKD 12	12	14	12½	8
FKD 14s	14	14	†	8

All dimensions in inches
 † FKD 14s overall length is 8".



model	A	A1	A2	C	D	E	F
FKD 12XL	12	12	14	17⅞	18⅞	7⅞	1⅞
FKD 14	14	12	14	17⅞	17¼	1	1⅞
FKD 14XL	14	14	16	19¾	20¼	1½	1¼
FKD 16	16	14	16	19¾	18¾	1½	1⅞
FKD 16XL	16	16	18	22½	23¼	1¼	1⅞
FKD 18	18	16	18	22½	21¾	1¼	1⅞
FKD 18XL	18	18	20	28¼	29¼	2	1¾
FKD 20	20	18	20	28¼	27¼	2	1¾

All dimensions in inches

FKD Air Performance Graphs

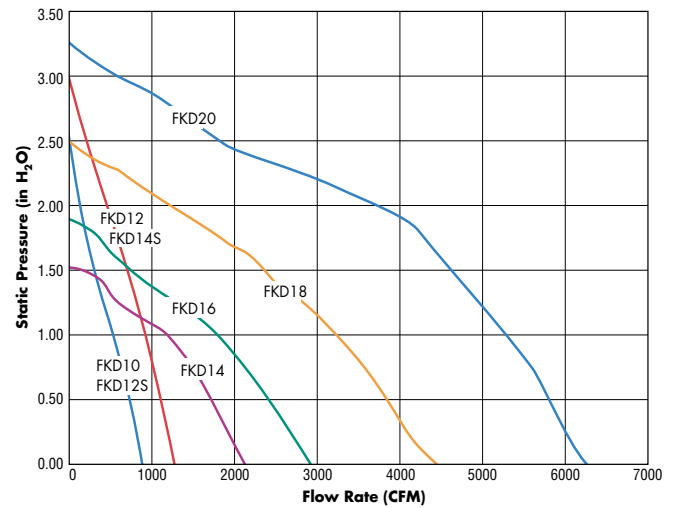
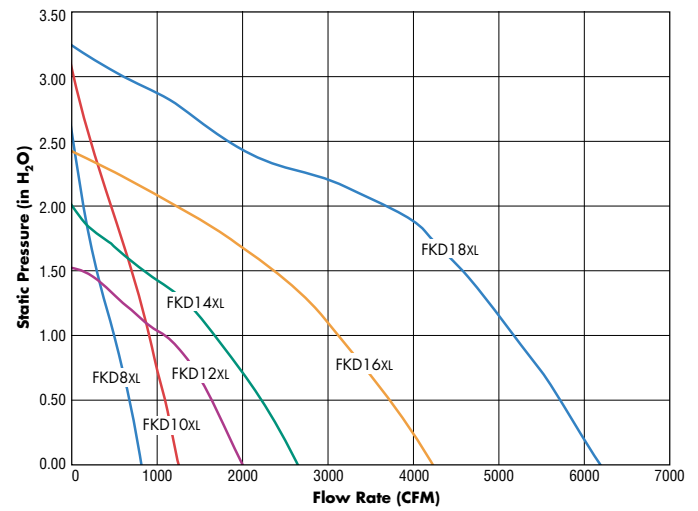

FKD Series Performance Data (For sound performance data refer to publication #FKD-0803 and FKD-1100/2)

Fan Model	RPM	Volts	Max. Watts	Max. Amps	Static Pressure in Inches W.G.										Max. Ps.	Duct Dia.	'Sones
					0"	.125"	.25"	.375"	.5"	.75"	1.0"	1.25"	1.5"	2.0"			
FKD 8XL	2700	115	327	2.99 ¹	836	799	761	720	680	595	499	393	286	—	2.59"	8"	14.1
FKD 10	2700	115	329	3.01 ¹	910	873	836	795	752	653	547	432	342	—	2.60"	10"	15.3
FKD 10XL	2850	115	529	4.84 ²	1266	1226	1187	1147	1100	1006	911	810	696	460	3.08"	10"	21
FKD 12s	2700	115	323	2.95 ¹	930	889	848	804	758	657	550	443	343	—	2.54"	12"	15.2
FKD 12	2900	115	531	4.86 ²	1305	1266	1228	1189	1145	1054	948	833	712	479	3.08"	12"	23
FKD 12XL	1700	115	500	4.80 ²	2016	1920	1832	1746	1649	1423	1066	606	—	—	1.52"	12"	18.7
FKD 14s	2900	115	525	4.81 ²	1305	1261	1218	1174	1125	1025	923	814	703	469	3.12"	14"	23
FKD 14	1700	115	495	4.76 ²	2156	2061	1965	1868	1764	1520	1193	623	—	—	1.52"	14"	18.4
FKD 14XL	1550	115	738	7.12 ²	2619	2517	2416	2303	2180	1936	1662	1294	843	—	1.94"	14"	19.0
FKD 16	1600	115	742	6.39 ²	2952	2831	2707	2580	2445	2144	1804	1306	774	—	1.90"	16"	18.5
FKD 16XL	1600	115	1421	12.40 ³	4274	4144	4014	3880	3743	3452	3137	2794	2379	1242	2.42"	16"	25
FKD 18	1600	115	1411	12.04 ³	4448	4992	4130	3991	3871	3583	3239	2843	2380	1231	2.51"	18"	24
FKD 18XL	1700	460/3	2208	3.75	6236	6115	5995	5874	5754	5500	5199	4909	4602	3703	3.24"	18"	32
FKD 20	1750	460/3	2218	3.73	6291	6174	6054	5933	5829	5617	5307	4987	4667	3757	3.27"	20"	33



Fantech, Inc. certifies that the FKD Series shown herein is licensed to bear the AMCA Seal. The ratings shown are based on tests and procedures performed in accordance with AMCA Publication 211 and AMCA Publication 311 and comply with the requirements of the AMCA Certified Ratings Program.

Performance shown is for installation type D - Ducted inlet, Ducted outlet. Speed (RPM) shown is nominal. Performance is based on actual speed of test. Performance ratings do not include the effects of appurtenances in the airstream. ¹ The sound ratings shown are loudness values in fan sones at 5ft. (1.5m) in hemispherical free field calculated per AMCA Standard 301. Values shown are for installation Type D: ducted inlet fan sone levels. Ratings do not include the effect of duct end correction. All sone values shown are calculated at 0.5" (static pressure in inches W.G.).

Note: Three phase motors are wound for 230/460 volt. Motors are prewired for 460 volts but may be delivered as 230 volt or may be rewired in the field.
¹ Recommended speed control rating 5A. ² Recommended speed control rating 10A. ³ Recommended speed control rating 15A.

Inlet and Exhaust Accessories

*Adjustable Metal Grills—MGE
Adjustable Plastic Grills—PGE*



Designer Grills—DG



Adjustable Supply Grills—PGS



Soffit Vent—UEV



Roof Caps—RC



Vent Light Combination Grill—VLC



▲ *Intake Guards—IG*



Louvered Shutters—VK & HS