

GREYSTONE ENERGY SYSTEMS INC

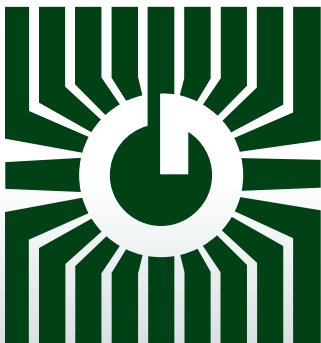

AIR QUALITY CONTROLLER-MONITOR AIR300 Series



Executive Space Enclosure (AE)



Duct Enclosure (D)

Precision air quality control / sensing

FEATURES:

- True Air Quality Monitor
- Microprocessor based controller
- Analog, stepped & relay output options
- Able to detect one cigarette in 15 m³ (540 cu. ft.) room
- Wall or duct mount versions
- Visual indication of air quality (Internal)

*Peace of mind
through reliable
gas monitoring*

GREYSTONE HAS AN ISO 9001 REGISTERED QUALITY SYSTEM

AIR QUALITY MONITOR / CONTROLLER

OPERATION

The AIR-300 Air Quality Monitor uses a tin dioxide semiconductor sensor to detect oxidizable gases and is specifically designed to have high sensitivity to gaseous organic materials which are components of indoor air pollutants. These air contaminants include cigarette smoke, smoke from cooking, exhaust gases from automobiles, solvents and many others.

Air quality is a term covering a very broad spectrum of definitions and factors. Temperature, humidity, air flow, occupancy and where the air is used all come into play when determining air quality. The air that is considered to be acceptable in a mechanical workshop may be quite unacceptable in an office environment.

A reliable method of measurement for air quality is found in a gas sensor based on the Taguchi Gas principle. This gas sensor is essentially a heated element inside a porous semiconductive tube. The tube has a large surface area and is able to freely absorb gas molecules on the semiconductor surface. Electron transfer occurs between the gas molecules and the already absorbed oxygen molecules. This causes a relatively large increase in conductivity for a small change in gas concentration. This change occurs quite quickly (within a few seconds) and is completely reversible. Since the element is a semiconductor Taguchi Gas Sensor and has no moving parts, it will operate reliably for many years. The sensor responds with varying degrees of sensitivity to a wide variety of gasses which include hydrogen, hydrocarbons, alcohols, carbon monoxide, benzene, etc.

It is readily apparent that this sensor works well in the detection of contaminants such as solvents, but what about carbon dioxide? Although the sensor does not detect carbon dioxide, it is still quite useful in human environments. As well as carbon dioxide, hydrocarbons, body odours and water vapors are emitted by breathing and perspiration. The levels of these other contaminants change at roughly the same rate as the carbon dioxide and the sensor will track these other contaminants at approximately the same rate as the carbon dioxide in occupied spaces.

The AIR-300 may be used as either a stand-alone controller to detect levels of pollution and operate a clean-air damper directly, or it may be used as a monitor where the analog output signal is transmitted to the Building Automation System for further processing.

Many different environments can be controlled with careful adjustment of the device parameters. This allows the AIR-300 to function equally well in a school room where the air is to be kept very clean, or a utility room where the fresh air requirements are not as stringent. The Air Quality Monitor can be used to control intake dampers at an airport where jet fumes are periodic contaminants, automatically control exhaust air on an assembly line where epoxies are used, or a multitude of other applicants.

Below is a list of common pollutants in decreasing order of sensitivity, detectable by the AIR-300. Most of these chemicals are easily detectable in quantities of 20 PPM or less.

CHEMICAL	SYMBOL	COMMON SOURCE
Methyl Ethyl Ketone	C ₄ H ₈ O	Solvents and cleaning products
Acetone	C ₃ H ₆ O	Solvents and organic synthesis
Ethyl Alcohol	C ₂ H ₆ O	Solvents and liquor fermentation
Formaldehyde	CH ₂ O	Disinfectants and preservatives
Hydrogen	H ₂	Used in synthetics
Methyl Alcohol	CH ₄ O	Solvents, antifreeze and synthetics
Vinyl Chloride	C ₂ HCl	Textiles and polymers
Hydrogen Sulfide	H ₂ S	Water and putrefying matter
Methyl Chloride	CH ₃ Cl	Solvents, paints and refrigerant
Benzene, Toluene, Xylene	C ₆ H ₆ , C ₇ H ₈ , C ₈ H ₁₀	Solvents and motor fuels
Trichloroethylene	C ₂ HCl ₃	Solvents and cleaning agents
Propane	C ₃ H ₈	Fuels and chemical synthesis
Carbon Monoxide	CO	Combustion of carbon
Freon-22	CHClF ₂	Refrigerants and aerosols
Ammonia	NH ₃	Solvents and refrigerants
Methane	CH ₄	Decomposition and synthesis

APPLICATION:

Environmental, industrial and commercial indoor Air Quality detector. Available in both space and duct mount versions.

- Schoolrooms
- Office buildings
- Parking garages
- Washroom ventilation fans
- Cigarette smoke detectors

FEATURES:

- True Air Quality Monitor
- Microprocessor based controller
- Analog, Stepped & Relay Output options
- 10 bit resolution
- Able to detect one cigarette in 15 m³ (530 cu. ft.) room
- Integral sensitivity adjustment
- Ability to directly control air handling unit
- Visual indication of air quality (internal)
- No calibration required

SPECIFICATION:

Sensor Type:.....	Solid State TGS-800 VOC sensor
Sample Method:.....	Diffusion or flow through sample tube for duct mounted models
Power Supply:.....	20 to 30 Vac/dc
Consumption:.....	100 mA max @ 24 Vdc, 220 mA @ 24 Vac, 6VA max.
Input Voltage Effect:.....	Negligible over specified operating range
Protection Circuitry:.....	Reverse voltage protected and output limited
Operating Temperature:.....	0° to 40°C (32° to 104°F)
Operating Humidity:.....	0 to 95% RH non-condensing
Standard Output Signal:.....	Analog Stepped Output (ASO) in four steps representing OK, Low, Medium and High pollution levels (each step is independently adjustable from 0-10 Vdc)
Optional Output Signal:.....	Linear output representing 0-100% pollution level, jumper selectable for either 0-5 or 0-10 Vdc or 4-20 mA, the current signal is generated by the sensor (active)
Output Drive at Capability:.....	550 ohms max for current output 10K ohms min for voltage output
Optional Relay Output:.....	One Form C contact (N.O. and N.C.) , status LED, 5 amps @ 250 Vac, 5 amps @ 30 vdc, p.f. = 1
Display:.....	5 LED's indicating pollution level, operational mode and programming values
Programming and Selection:.....	Via internal push-buttons and jumpers
Wiring Connections:.....	Screw terminal block (14 to 22 AWG)
External Dimensions:.....	Executive Space, 70 mm W x 118 mm H x 32 mm D (2.75" x 4.65" x 1.25") Duct, 124.5 mm W x 183.5 mm H x 250.5 mm D, (7.2" x 4.9" x 9.9") includes probe
Enclosure Ratings:.....	Executive Space - IP30, NEMA 1 Duct - IP20, NEMA 2

PRODUCT ORDERING INFORMATION

MODEL	Description
AIR300	Air Quality Monitor / Controller

CODE	Enclosure
AE	Executive Space
D	Duct

CODE	Output Option
-	Analog Stepped Output Only (no designation)
R	ASO and Relay Outputs
A	ASO and Analog Outputs
AR	ASO, Analog and Relay Outputs

AIR300	D	AR	← Typical Model Number
--------	---	----	------------------------

Example: Air Quality Duct c/w ASO, analog and relay outputs

Greystone Energy Systems Inc. reserves the right to make design modifications without prior notice.

ENCLOSURE DIMENSIONS:

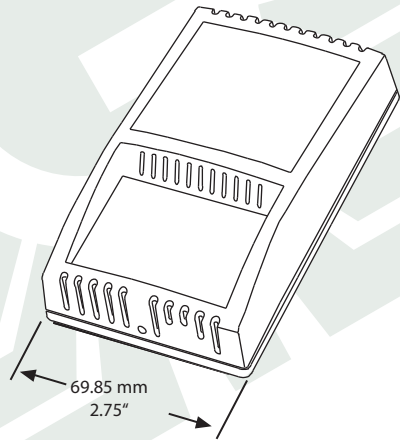

Executive Enclosure

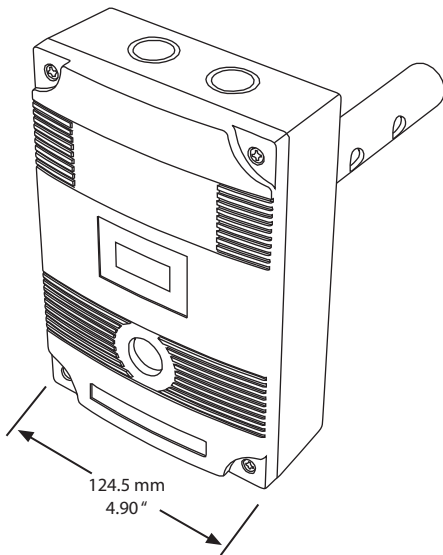
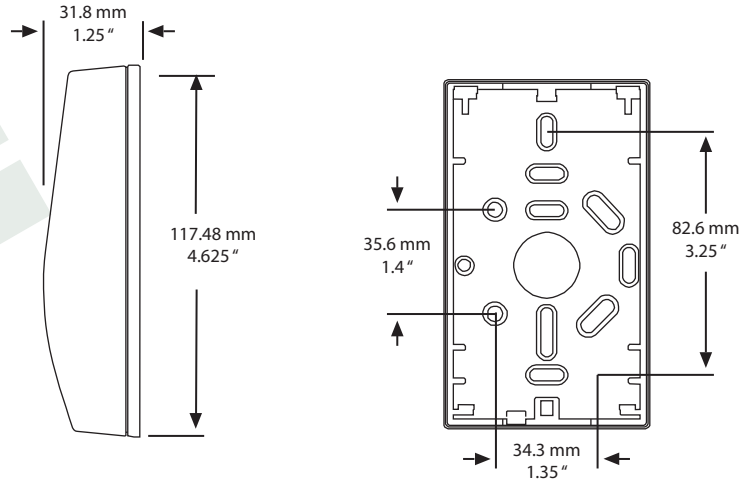

Duct ABS Enclosure

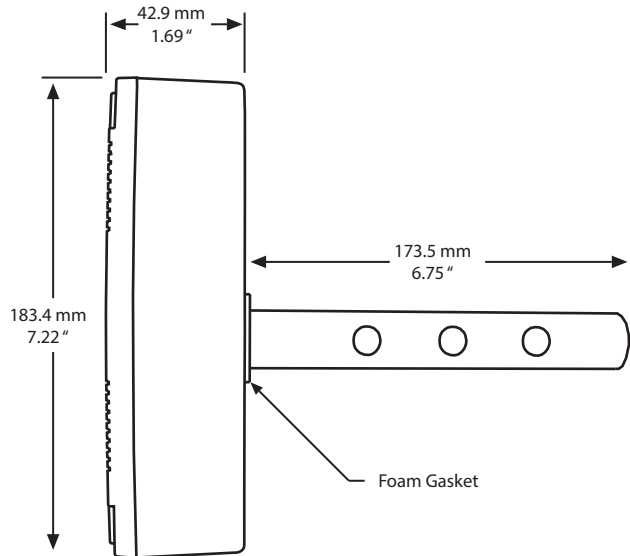

GREYSTONE

ENERGY SYSTEMS INC

Greystone Energy Systems Inc.
 150 English Drive, Moncton,
 New Brunswick, Canada E1E 4G7
 (506) 853-3057 Fax: (506) 853-6014
 North America: 1-800-561-5611
 e-mail: mail@greystoneenergy.com
 web site: www.greystoneenergy.com

RoHS
COMPLIANT



Greystone Energy Systems Inc. is one of North America's largest ISO registered manufacturers of HVAC/R sensors and transmitters for Building Automation Management Systems.

We have conscientiously established a worldwide reputation as an industry leader by maintaining leading-edge design technology, prompt technical support, and a commitment to on-time deliveries. We take pride in our Quality Management System which is ISO 9001 certified, assuring our customers of consistent product reliability.

GREYSTONE HAS AN ISO **9001** REGISTERED QUALITY SYSTEM