

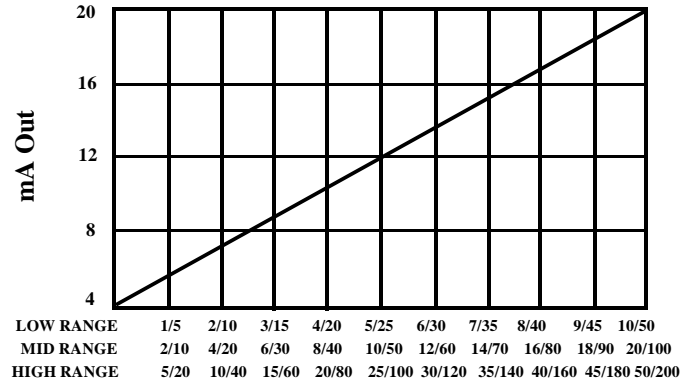

Model CS-475/SC-575
AC Amps



Operation

These sensors can be used to monitor motors, pumps, machine tools, conveyors or other electrical loads where an analog representation of the load current is required over a wide range of currents. The output can sense proper fan, pump or motor operation and failure, including belt or bearing loss as well as monitor machine feed rates and tool wear.

These 4-20 mA sensors are loop powered devices that require an external 15-42 Vdc power supply. The total power supply must be 10 Vdc + (RI * 20 mA) where RI is the input resistance of the device measuring the signal. Therefore, if RI is 250 ohms, the minimum power supply is 15 Vdc. These sensors also have a linear output of 4 - 20 mA over all six selectable ranges (three ranges each for the -1 and -2 devices). A connection diagram is shown below. The line current is calculated as $I_{line} = (I_{loop} - 4 \text{ mA}) * I_{range} / 16$.

Specifications:

CS-475 / SC-575			
Power Supply	15-42 Vdc at sensor (loop powered)	Operating Temperature	0 to 40 °C (32 to 104 ° F)
Input Current Ranges	Three field selectable ranges, 0-10/0-20/0-50 Amps or 0-50/0-100/0-200 Amps	Operating Humidity	0 to 95% RH, non-condensing
Maximum Input Current	10/20/50 Amp ranges – 80/120/200 Amps continuous 50/100/200 Amp ranges – 175/300/400 Amps continuous	Protection Circuitry	Reverse voltage protected and output limited
Response Time	250 mS (0-90%)	Wiring	Solid Core – Barrier strip
AC Conductor Hole	Split Core – 20mm (0.8”) diameter Split Core – 24 x 19 mm (0.95 x 0.75”)	Enclosure Material	UL 94 V-0 flammability rated ABS
Enclosure Size (H x W x D)	Solid Core – 49 x 87 x 25 mm (1.95 x 3.45 x 1.0”) Split Core – 70 x 87 x 30 mm (2.75 x 3.45 x 1.2”)	Manufacturing	ISO 9001 Certified
Output Signal & Accuracy	4 to 20 mA represents 0 to 100% of current span. Better than ±1% FS on all three ranges		

Order Information

Model	Output	Accuracy	Frequency	Amp Ranges	Model	Output	Accuracy	Frequency	Amp Ranges
CS-475-0	4-20 mA	±1% FSO	10 – 400 Hz	0-2/0-5/0-10	SC-575-0	4-20 mA	±1% FSO	10 – 400 Hz	0-2/0-5/0-10
CS-475-1	4-20 mA	±1% FSO	10 – 400 Hz	0-10/0-20/0-50	SC-575-1	4-20 mA	±1% FSO	10 – 400 Hz	0-10/0-20/0-50
CS-475-2	4-20 mA	±1% FSO	10 – 400 Hz	0-50/0-100/0-200	SC-575-2	4-20 mA	±1% FSO	10 – 400 Hz	0-50/0-100/0-200

Installation

Disconnect and lock-out all power sources during installation as severe injury or death can result from electrical shock due to contact with high voltage conductors. Ensure all installations are in compliance with applicable electrical codes and that the installation is completed by qualified installers familiar with the standards and proper safety procedures for high-voltage installation. Never rely on status indicating devices only to determine if power is present in a conductor.

Insure the range selection jumper is installed in the correct position for the current being monitored. Excessive current can damage the sensor. See below for information on setting the jumpers.

Install the Split-Core over the conductor to be monitored and close the sensor until it latches, ensuring that the two halves are properly aligned. Operation of the sensor will be impaired if any dirt particles prevents good contact between the core pieces when the device is closed, keep the sensor clean when it is opened.

Mount the switch in a suitable location using the two mounting holes in the base of the unit.

The conductor may be looped more than once through the sensor to multiply the sensitivity but this also divides the maximum currents. For example, on the 0-200 amp scale, if the conductor is looped through twice, the maximum current will now be 100 amps.

Connect the output circuit to the two screw terminals using ring or fork type terminals. Typical connections are shown in the wiring examples. Note polarity as indicated on the device label.

To allow field calibration, all devices have easily accessible calibration pots. The devices may be calibrated to custom ranges

Calibration Pot Location

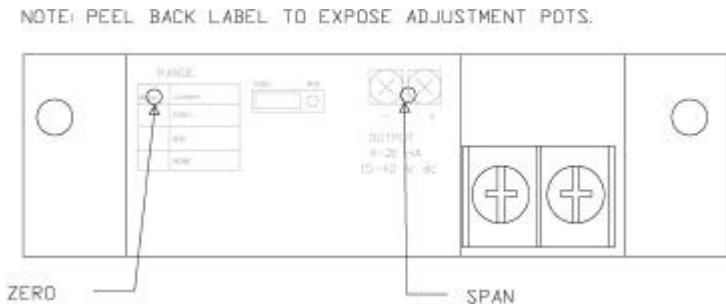

NOTE: PEEL BACK LABEL TO EXPOSE ADJUSTMENT POTS.

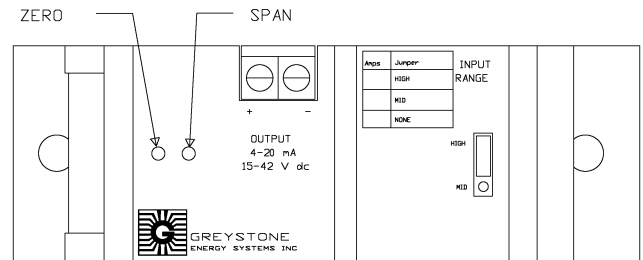

Wiring

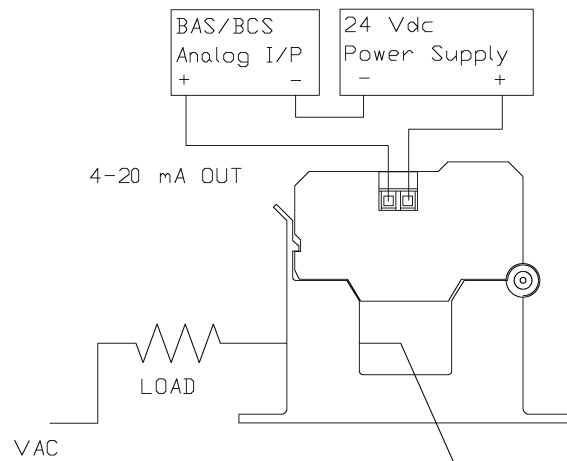
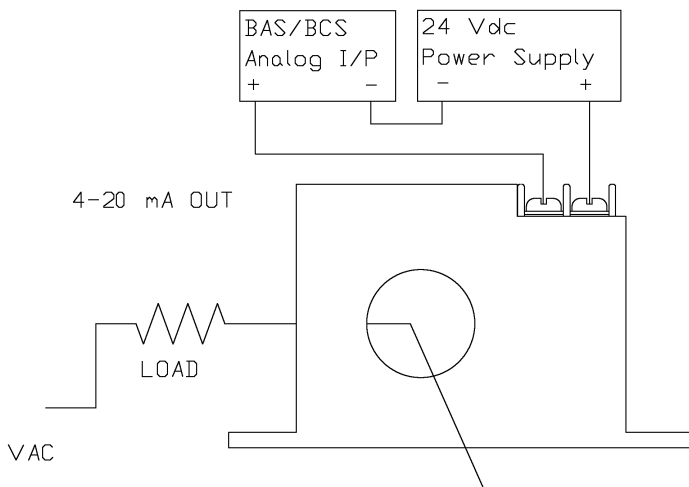

Jumper Settings

To set the range on the sensor determine from the chart on the label which range will be used. Then place the jumper on the indicated pins. For none remove the jumper from all pins. The examples to the right show the jumper in the High position.

