

Operation

The output switch of all devices is normally open, when the monitored current exceeds the trip value as set by the multi-turn adjustment the switch will close. If the unit has a status LED, it will light to indicate a closed switch. Devices that also feature a power LED will indicate circuit power whenever there is sufficient current flowing in the conductor to operate the device circuitry, typically 1 Amp minimum for solid-core units and 1.5 Amp minimum for split-core devices. (See table on next page)

All devices are factory set at the minimum switch point (adjustment fully clockwise). To increase the set point, while the monitored load is on, turn the adjustment counter-clockwise until the output turns off as indicated by either the status LED or a voltmeter connected across the device output to indicate an open switch. Then turn the adjustment clockwise until the LED comes back on to indicate a closed switch or a voltmeter indication is seen. The adjustment should be turned slightly clockwise past this point to ensure normal line current variations do not cause false conditions. The GNG series is not adjustable.

USING THE SC510 SWITCH TO CONTROL A LOAD

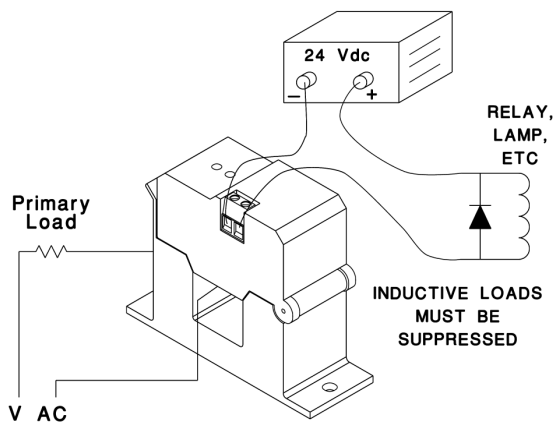

USING THE CS410 SWITCH TO SIGNAL A DIGITAL INPUT

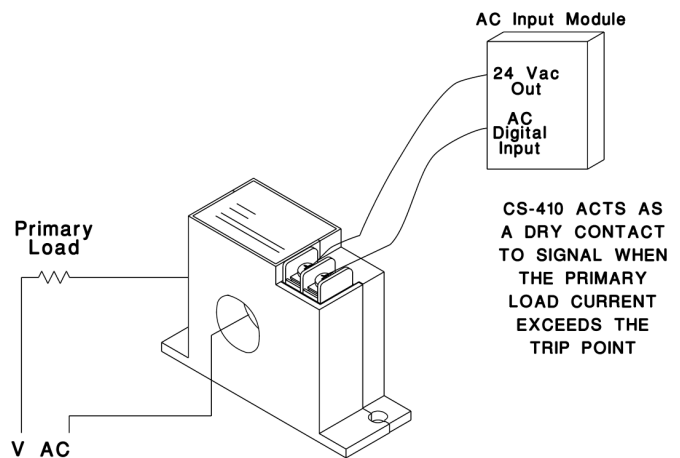

Installation

Disconnect and lock-out all power sources during installation as severe injury or death can result from electrical shock due to contact with high voltage conductors. Ensure all installations are in compliance with applicable electrical codes and that the installation is completed by qualified installers familiar with the standards and proper safety procedures for high-voltage installation. Never rely on status indicating devices only to determine if power is present in a conductor.

Ensure that the output circuit to be switched is within the device switch ratings as shown in the chart, less than Switch V Max and less than Switch I Max.

If the device has a selectable range selection jumper, insure it is installed in the correct position for the current being monitored. Excessive current can damage the sensor. Auto-range devices will monitor any current over the entire range of Input I Min to Input I Max Amps as shown in the table.

Solid-Core devices require that the line to be monitored be disconnected and routed through the center of the device while Split-Core units can be easily installed over existing wires without the need to disconnect the circuit.

Install the Split-Core over the conductor to be monitored and close the sensor until it latches, ensuring that the two halves are properly aligned. Operation of the sensor will be impaired if any dirt particles prevents good contact between the core pieces when the device is closed, keep the sensor clean when it is opened.

Mount the switch in a suitable location using the two mounting holes in the base of the unit.

The conductor may be looped more than once through the sensor to multiply the sensitivity but this also divides the maximum currents.

Connect the switch circuit to the two screw terminals using ring or fork type terminals. Typical connections are shown in the wiring examples. The switches are not polarity sensitive and operate as a "dry contact".

Model	Output Type	Type	Switch V Max	I Max	Von @ 24Vdc @ 150 mA	Leakage Current	Power LED	Status LED	Auto Range	Input I Min	Input I Max
CS-GnG	Mosfet	AC/DC	30Vac/40Vdc	500 mA	<0.1 V	<25 μ A	No	No	Yes	1.0A	200A
CS-GnG-L	Mosfet	AC/DC	30Vac/40Vdc	500 mA	<0.1 V	<25 μ A	No	No	Yes	0.5A	200A
CS-410	Mosfet	AC/DC	30Vac/40Vdc	500 mA	<0.1 V	<25 μ A	Yes	Yes	Yes	1A	200A
CS-325	Triac	AC	250Vac	1 Amp	n/a	<5 mA	No	No	No	1.25A	200A
CS-325-NS	Triac	AC	250Vac	1 Amp	n/a	<1 mA	No	No	No	1.25A	200A
SC-GnG	Mosfet	AC/DC	30Vac/40Vdc	500 mA	<0.1 V	<25 μ A	No	No	Yes	1.5A	200A
SC-510	Mosfet	AC/DC	30Vac/40Vdc	500 mA	<0.1 V	<25 μ A	Yes	Yes	Yes	1.5A	200A
SC-525-S	Triac	AC	250 Vac	500 mA	n/a	<5 mA	No	No	No	1.5A	150A
SC-525-NS	Triac	AC	250 Vac	500 mA	n/a	< 1 mA	No	No	No	1.5A	150A