

# GREYSTONE

## ACCURACY BY DESIGN

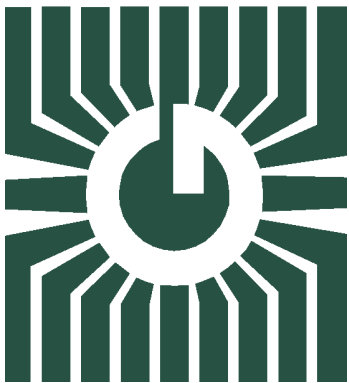

## GAUGE PRESSURE TRANSDUCERS PGS SERIES



### FEATURES:

- 1/4" NPT
- NIST traceable calibration
- Weather resistant for harsh environments
- Fast response time
- Capacitance sensing element
- Ranges -14.7 through 10,000 PSIG (-101.4 through 68947.6 kPa)
- Accuracy to  $\pm 0.25\%$  FSO
- DC inputs, current output
- Compensated temperature range: -20°C to 80°C (-4°F to 176°F)
- Operating temperature range: -40°C to 127°C (-40°F to 260°F)
- 17-4PH Stainless Steel has excellent corrosion resistance (comparable to grade 304 stainless)

***Peace of mind  
through reliable  
pressure transducers***

GREYSTONE HAS AN **ISO 9001** REGISTERED QUALITY SYSTEM

## APPLICATIONS:

- HVAC Systems
- Energy Management Systems
- Steam Pressures
- Refrigerants and Ammonia
- Gas Chromatography
- Paint Spraying Systems
- Electronic Pressure Switch
- Heat Pumps
- Hydraulic Systems
- Irrigation Systems
- Compressor Control
- Propane

## SPECIFICATIONS:

PGS100 Series	
Accuracy at Constant Temp.	.25% F.S.O
Supply Voltage	Minimum supply voltage (VDC) = $9 + 0.02 \times (\text{Resistance of receiver plus line})$ . Maximum supply voltage (VDC) = $30 + 0.004 \times (\text{Resistance of receiver plus line})$ .
Output	4 to 20 mA
External Load	0 to 800 ohms
Media Compatibility	17 – 4PH stainless steel
Pressure Port	1/4" - 18 NPT External
Operating Temp. Range (sensor)	-40°C – 127°C (-40°F–260°F)
Compensated Temp. Range	-20°C – 80°C (-4°F – 176°F)
Zero Thermal Shift	< $\pm 2\%$ of F.S.
Span Thermal Shift	< $\pm 1.5\%$ of F.S.
Pressure Overload	See pressure scale chart

## PRESSURE RANGES:

Code	Full Scale Pressure Range PSI	Proof Pressure PSI	Burst Pressure PSI
4A1A	-14.7-15 PSIG (-101.4-103.4 kPa)	20	500
5A1A	-14.7-30 PSIG (-101.4-206.8 kPa)	50	500
6A1A	-14.7-60 PSIG (-101.4-413.7 kPa)	100	750
7A1A	-14.7-100 PSIG (-101.4-689.5 kPa)	200	1000
8A1A	-14.7-150 PSIG (-101.4-1034.2 kPa)	400	2000
9A1A	0-10 PSIG (0-68.95 kPa)	20	500
10A1A	0-25 PSIG (0-172.4 kPa)	50	500
11A1A	0-50 PSIG (0-344.7 kPa)	100	750
12A1A	0-100 PSIG (0-689.5 kPa)	200	1000
13A1A	0-150 PSIG (0-1034.2 kPa)	400	2000
14A1A	0-200 PSIG (0-1379 kPa)	400	2000
15A1A	0-250 PSIG (0-1723.2 kPa)	500	2000
16A1A	0-300 PSIG (0-2068.4 kPa)	500	2000
17A1A	0-500 PSIG (0-3447.4 kPa)	1000	3000
18A1A	0-1000 PSIG (0-6894.8 kPa)	2000	5000
19A1A	0-5000 PSIG (0-34473.8 kPa)	7500	10,000
20A1A	0-10,000 PSIG (0-68947.6 kPa)	12,500	20,000

## PRODUCT DESCRIPTION:

**PGS100A** is a compact gauge pressure transducer complete with a 2 wire 4-20mA output, various pressure ranges, 1/4" NPT connection and 2 foot cable for electrical termination.

## MEDIA COMPATIBILITY:

The PGS100 Series transducers are designed to be used with any gases or liquids compatible with 17-4PH stainless steel. The 17-4PH stainless has excellent corrosion resistance. Corrosion tests and service experience have shown that in all aged conditions it is superior to standard hardenable stainless grades such as 420, 431 and 410 stainless. This corrosion resistance is comparable to 304 stainless. Note it is not recommended for hydrogen applications.

## ORDER EXAMPLE:

To order a **PGS-100A**, **0 – 200 PSIG Range**, **supply voltage of 24 VDC**, **output of 4-20mA**, the following order number would apply:  
**PGS100A14A1A**

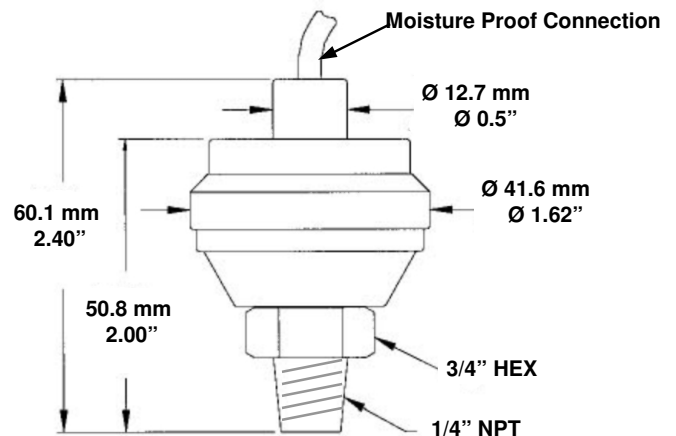

Greystone Energy Systems Inc.  
150 English Drive, Moncton, NB  
Canada E1E 4G7

(506) 853-3057 Fax: (506) 853-6014  
North America: 1-800-561-5611  
e-mail: mail@greystoneenergy.com  
www.greystoneenergy.com

GREYSTONE HAS AN ISO 9001 REGISTERED QUALITY SYSTEM

