

**remote duct
sensor**

specifications:

description: Duct sensor for remote temperature reading. Must be used with a temperature controller PTA or a X-200 from Neptronic

sensor: NTC (negative temperature coefficient)

curve: A

tolerance: $\pm 2^{\circ}\text{C}$ to 35°C (35° to 95°F)

encapsulation: black epoxy

leads: AWG 28, Ag/cu, Kynar 460
white/white, 2 conductors twisted

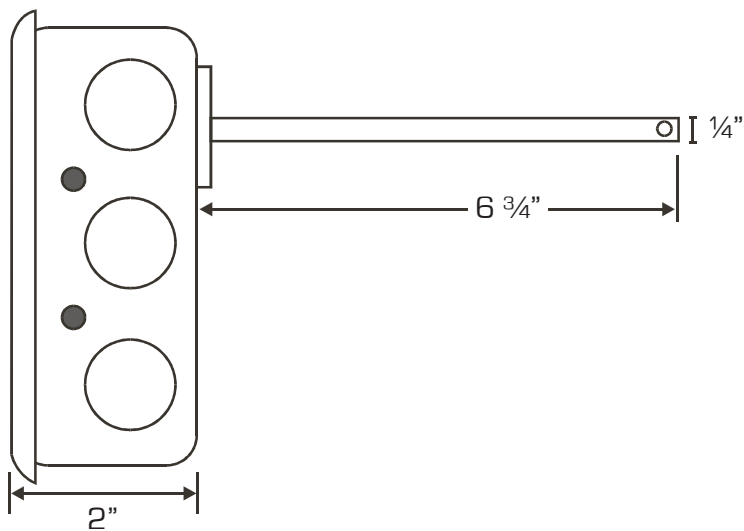
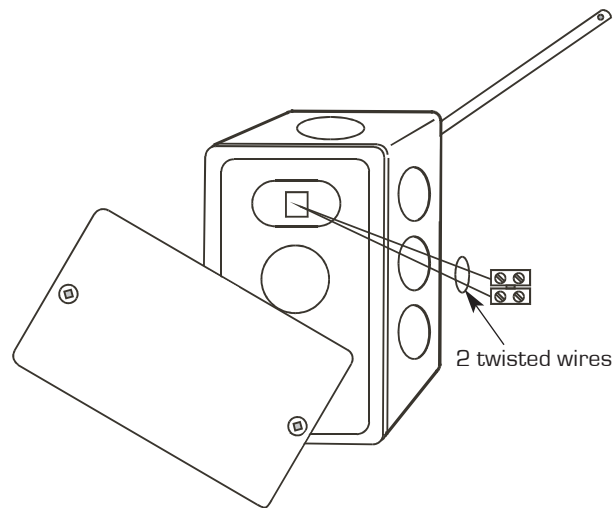

side view

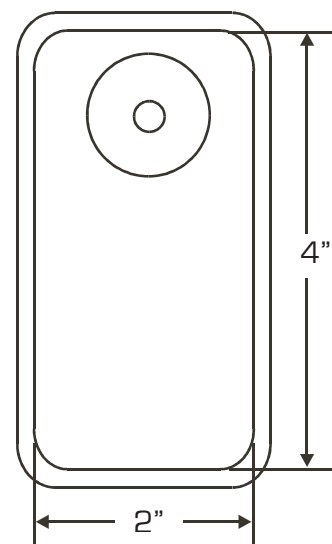

back view