

'SFB' Inline Filter Boxes

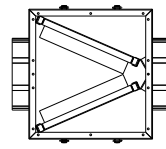

☒ V Bank

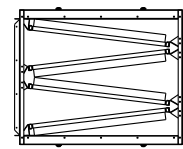

☐ W Bank

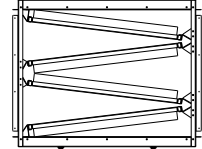

☐ Insulated W Bank

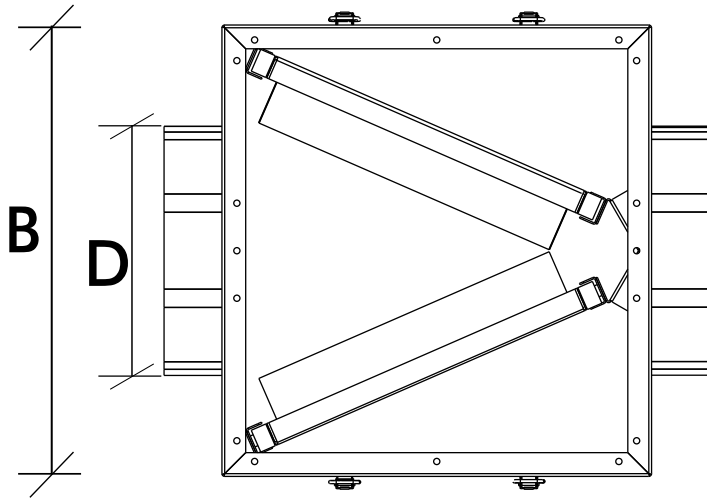

Front View

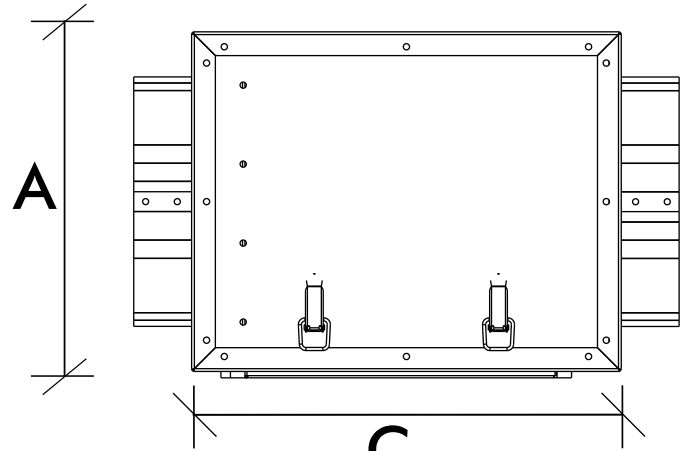

Top View

Features:

- Ultra low leakage design
- Gasketed door and filter contact area
- 'V' bank design has greater filter area
- Large filter area => lower pressure drop and large dust holding capacity
- White painted aluminum casing

Model	Filters	Dimensions				Airflows (CFM)				Filter Area (square feet)
						Maximum		Recommended		
		A	B	C	D	CFM	Pressure Drop (MERV13)	CFM	Pressure Drop (MERV13)	
SFB-V-10x10	2 qty 10x10x2	10.2	14.6	11.9	8.0	694	0.29	417	0.12	1.39
SFB-V-16x16	2 qty 16x16x2	16.3	18.7	17.6	12.0	1,778	0.29	1,067	0.12	3.56
SFB-V-16x25	2 qty 16x25x2	16.2	20.9	26.7	14.0	2,778	0.29	1,667	0.12	5.56

Notes:

- All dimensions in inches

- Maximum airflow is with filter face velocity of 500 feet/minute

- Recommended airflow is with filter face velocity of 300 feet/minute