





RESIDENTIAL SYSTEM SOLUTIONS
FAK-II
 IAQ Fresh Air Kits

PRODUCT
 SPECIFICATIONS
 & TECHNICAL
 DATA

American Aldes FAK-II Fresh Air Kits are ideal for use with forced air heating or cooling systems. FAK-II Kits introduce controlled amounts of fresh air per ASHRAE 62 Standards. The kit is designed for A/C dominant climates and prevents costly over ventilation.

The key element of the FAK-II is the integrated, pressure-independent Constant Airflow Regulator (CAR-II) that limits the volume of fresh air introduced to the forced air conditioning or heating system. Once connected to the return plenum of a forced-air system, each FAK-II has 3-4 adjustable CFM settings so that homes are not over-ventilated (wasting energy) or under-ventilated (poor Indoor Air Quality). The CAR-II eliminates the need for field balancing or adjustment. Each kit includes a CAR-II, a galvanized steel sleeve, and a galvanized steel all-weather wall hood. See FAK-II-MD Kits for models with 24 VAC motorized dampers.

If a forced air system is not present, please see the IAQ-DSVS system package.

FAK-II – Fresh Air Kits					
Part Number	Kit	Airflow (CFM)	CAR-II	Wall Hood*	Sleeve
					
65 035A	FAK-II - 5" Diameter	35/45/50	1 (5")	1	1
66 075A	FAK-II - 6" Diameter	75/90/105	1 (6")	1	1
68 125A	FAK-II - 8" Diameter	125/140/160/175	1 (8")	1	1
68 205A	FAK-II - 8" Diameter	205/235/265/295	1 (8")	1	1

* Galvanized standard. Contact American ALDES to request copper or stainless steel.

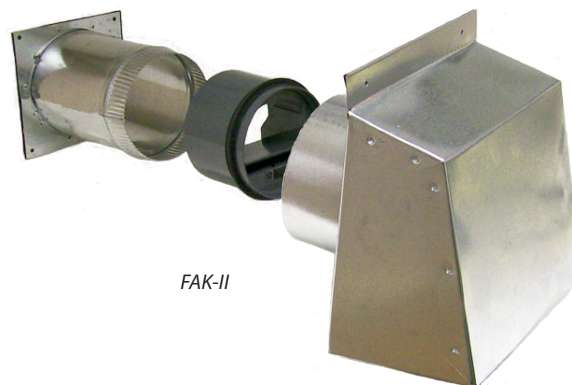

FAK-II

© 2014 American ALDES Ventilation Corporation. Reproduction or distribution, in whole or in part, of this document, in any form or by any means, without the express written consent of American ALDES Ventilation Corporation, is strictly prohibited. The information contained within this document is subject to change without prior written notice.

American ALDES Ventilation Corporation • 4521 19th Street Court East, Suite 104 • Bradenton, FL 34203 – USA
 941.351.3441 • 800.255.7749 • 941.351.3442 (fax) • info@americanaldes.com • www.aldes.us



AIRFLOW & ZONE CONTROLS

CAR-II

Constant Airflow Regulator

PRODUCT
SPECIFICATIONS
& TECHNICAL
DATA



GENERAL

The model CAR-II Constant Airflow Regulator is a modulating orifice that automatically regulates airflows in duct systems to constant levels. The passive control element responds to duct pressure and requires no electric or pneumatic sensors or controls.

The CAR-II compensates for changes in duct pressure caused by thermal stack effect, building pressure, dust-clogged filters, etc. The CAR-II also provides a low-cost solution to balancing forced-air systems for heating, air conditioning and ventilation, eliminating the need for on-site balancing. The CAR-II will regulate airflow in supply, return, or exhaust duct systems.

The active control element of the CAR-II is a unique aerofoil. Using Bernoulli's Principle, the aero-wing damper lifts in response to increasing static pressure. This operation regulates the free-area opening through the control, resulting in maintenance of velocity and specific airflow set points. Each CAR-II is designed and produced for control of air in temperatures ranging from -25°F to 140°F (-32°C to 60°C).

CONSTRUCTION

The round CAR-II is constructed of a UL94V-0 ABS plastic, and it is UL 2043 safety classified and labeled for flame and smoke generation. The assembly is sized to fit inside standard rigid round ducting, as well as fittings such as take-offs, tees, etc. A lip or flex-type ring seal gasket around the circumference ensures a tight, no-leak fit.

PERFORMANCE

The CAR-II airflow regulators control airflow accurately to within 10% of rated flow (15% for units 50 CFM or less) throughout the target operating pressure range of 0.2 to 0.8 in. w.g. (50 to 200 Pa). Each CAR-II is factory tested and calibrated to the rated set point before shipping. On-site field adjustment of airflow set points can be made for supply air applications (contact factory). Each diameter of CAR-II regulator is available in multiple factory-calibrated set points (see performance curves).

MAINTENANCE

The CAR-II needs no maintenance when used in normal conditions. There is no risk of dust deposit or obstruction because the CAR-II has no airways subject to clogging. If the intended application includes air heavily loaded with grease or dust, a fitting with an access panel or door, such as that used for flame dampers, should be provided.

WARRANTY

Guaranteed for 5 years, from date of shipment, against all defects in material or workmanship, provided that the material has been installed and used under normal conditions. This warranty is limited to the repair or replacement of the material.

CAR-II Dimensions

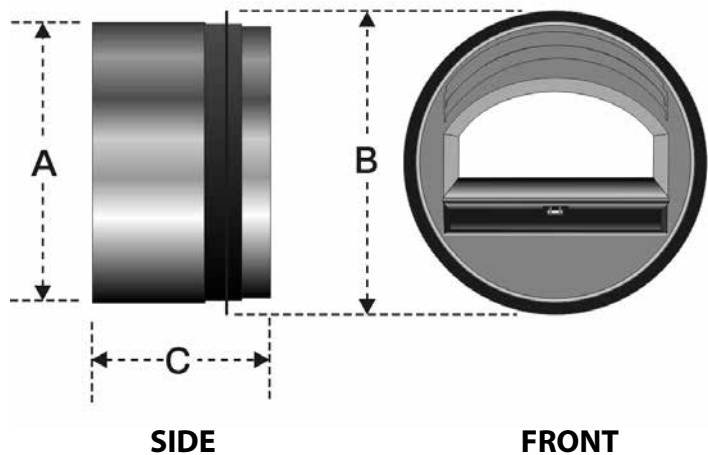

DUCT	CAR-II	A	B	C
4"	4"	3.8"	4.1"	2.3"
5"	5"	4.8"	5.1"	3.5"
6"	6"	5.8"	6.1"	3.5"
8"	8"	7.6"	8.1"	3.5"
10"	10"	9.7"	10.1"	3.7"

How the CAR-II Works

Constant airflow is achieved by controlling the free area through the device. At minimum static pressure, the aero-wing is parallel to the air stream. As the static pressure increases, the aero-wing lifts, reducing the amount of free area through the regulator. At the same time, higher static pressure increases the air velocity resulting in **CONSTANT AIRFLOW**. This occurs regardless of pressure differences in the range of 0.2 to 0.8 in. w.g. (50 to 200 Pa). The air velocity in the duct is in the range of 60 to 700 ft/min. (0.3 to 3.5 m/s).

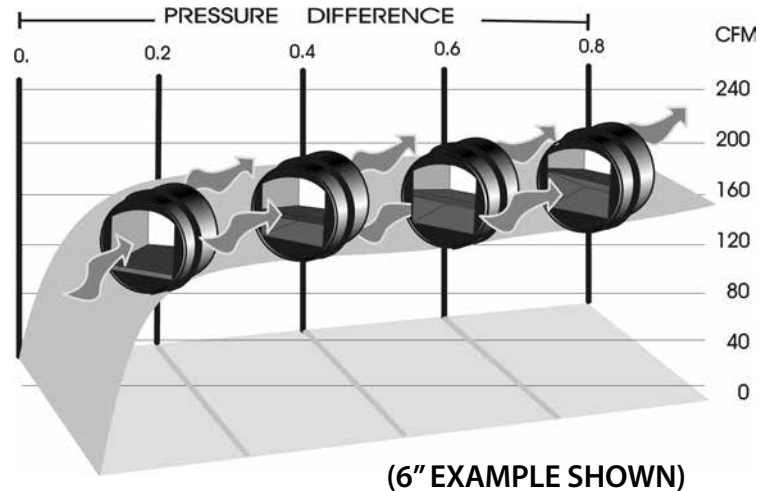

Typical CAR-II Applications

- Supply and exhaust air in offices.
- Balancing exhaust and supply airflows in high-rise building duct risers.
- Bathroom exhaust in nursing homes, hotels, motels, dormitories, apartment buildings, offices, etc.
- Clean room air supply balancing for ceiling filter modules. Maintains constant airflow even as filter resistance increases.
- Regulation of make-up air.
- Controlling conditioned air to sealed crawlspaces.
- Balancing supply airflow from packaged roof-top A/C units.
- Balancing supply and exhaust of heat recovery ventilation systems.
- Regulating outdoor air injection from central supply fan into individual room fan coil units or heat pumps.
- Balancing airflows on series-fan-powered terminal unit systems.
- Supply air to sleeping quarters in military facilities, submarines, etc.

Typical Specification

Model CAR-II Constant Airflow Regulators by American ALDES Ventilation Corporation, Bradenton, Florida, shall solely operate on duct pressure and require no external power supply. Each regulator shall be pre-set and factory calibrated, requiring no field adjustment to the airflows as indicated on the schedule, and shall be rated for use in air temperatures ranging from -25° to 140°F (-32° to 60°C.)

Constant airflow regulators shall be capable of maintaining constant airflow within +/- 10% of scheduled flow rates (15% for units 50 CFM or less), within the operating range of 0.2 to 0.8 in. w.g. differential pressure, or 0.6 to 2.4 in. w.g. on high-pressure models (CAR-II-HP), or 0.1 to 0.42 in. w.g. on low-pressure models (CAR-II-LP). Regulators shall be provided as an assembly consisting of a 94V-0 UL ABS plastic body housed within a round sleeve for mounting in round duct. Each round sleeve must be fitted with a lip gasket to ensure perimeter air tightness with the interior surface of the duct. All regulators must be classified per UL 2043 and carry the UL mark indicating compliance. All Constant Airflow Regulators will require no maintenance and must be warranted for a period of no less than five years. Constant Airflow Regulators shall be installed in tight ducting systems in accordance with all applicable codes and manufacturer's instructions.

CAR-II Airflow Performance Data

Performance charts reflect airflow measurements taken at 68°F (20°C) at 1 atmosphere pressure. The CAR-II is designed for system pressures between 0.2 and 0.8 in. w.g. Models are also available for applications with system pressures between 0.1 and 0.42 in. w.g (CAR-II-LP) and above 0.8 in. w.g. (CAR-II-HP).

4" DIAMETER (100 mm) REGULATING ELEMENT

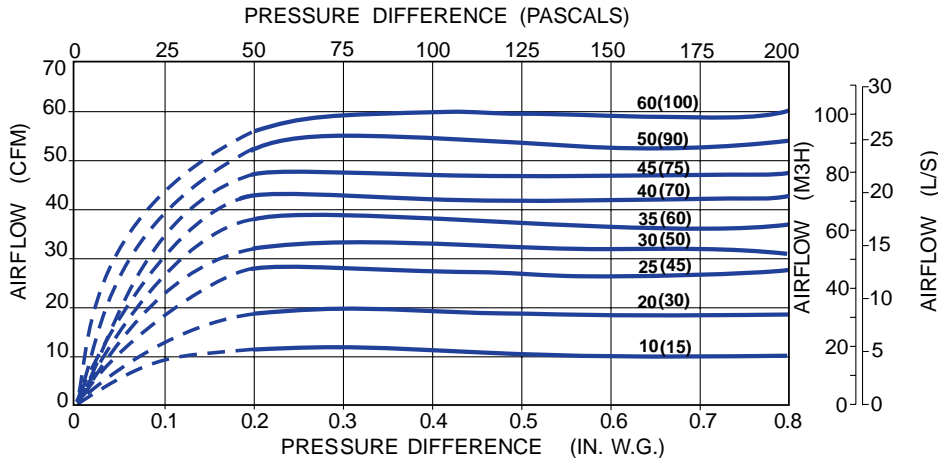

PART NUMBER	AIRFLOW
18 111	10 CFM (15 m ³ /h)
18 112	20 CFM (30 m ³ /h)
18 113	25 CFM (45 m ³ /h)
18 114	30 CFM (50 m ³ /h)
18 115	35 CFM (60 m ³ /h)
18 109	40 CFM (70 m ³ /h)
18 116	45 CFM (75 m ³ /h)
18 117	50 CFM (90 m ³ /h)
18 118	60 CFM (100 m ³ /h)

5" DIAMETER (125 mm) REGULATING ELEMENT

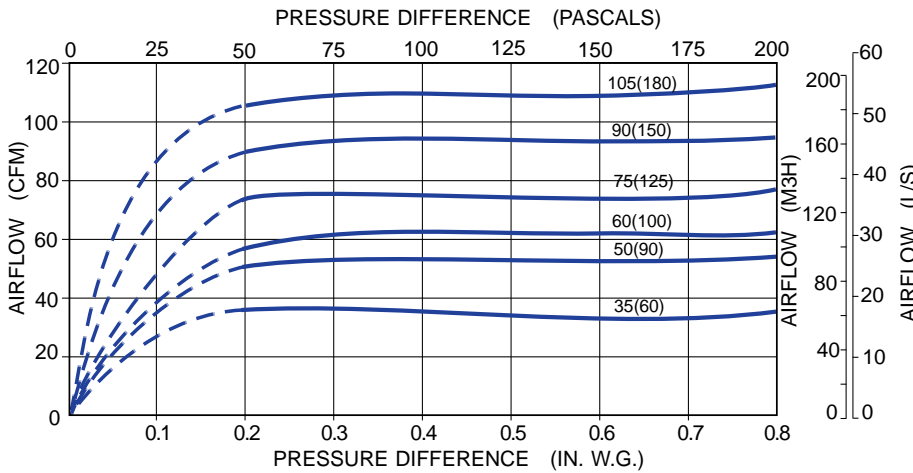

PART NUMBER	AIRFLOW
18 121	35 CFM (60 m ³ /h)
18 122	50 CFM (90 m ³ /h)
18 123	60 CFM (100 m ³ /h)
18 124	75 CFM (125 m ³ /h)
18 125	90 CFM (150 m ³ /h)
18 126	105 CFM (180 m ³ /h)

6" DIAMETER (150 mm) REGULATING ELEMENT

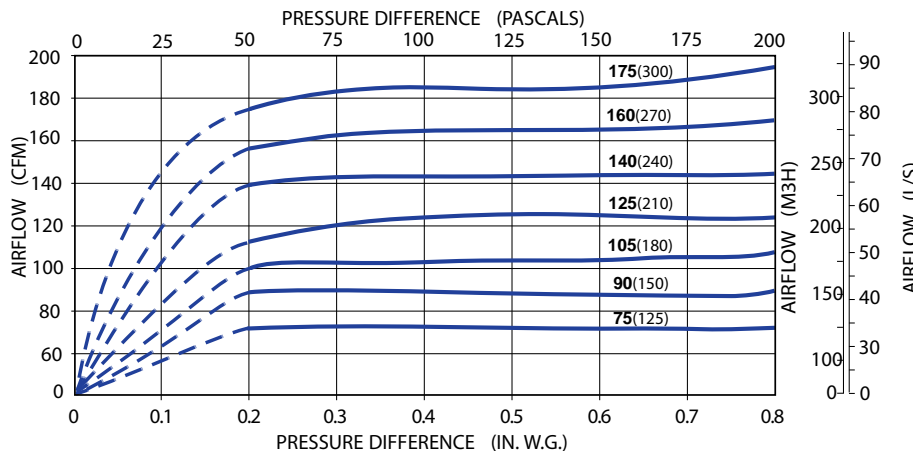

PART NUMBER	AIRFLOW
18 131	75 CFM (125 m ³ /h)
18 132	90 CFM (150 m ³ /h)
18 133	105 CFM (180 m ³ /h)
18 134	125 CFM (210 m ³ /h)
18 135	140 CFM (240 m ³ /h)
18 136	160 CFM (270 m ³ /h)
18 137	175 CFM (300 m ³ /h)

CAR-II Airflow Performance Data

Performance charts reflect airflow measurements taken at 68°F (20°C) at 1 atmosphere pressure. The CAR-II is designed for system pressures between 0.2 and 0.8 in. w.g. Models are also available for applications with system pressures between 0.1 and 0.42 in. w.g (CAR-II-LP) and above 0.8 in. w.g. (CAR-II-HP).

8" DIAMETER (200 mm) REGULATING ELEMENT

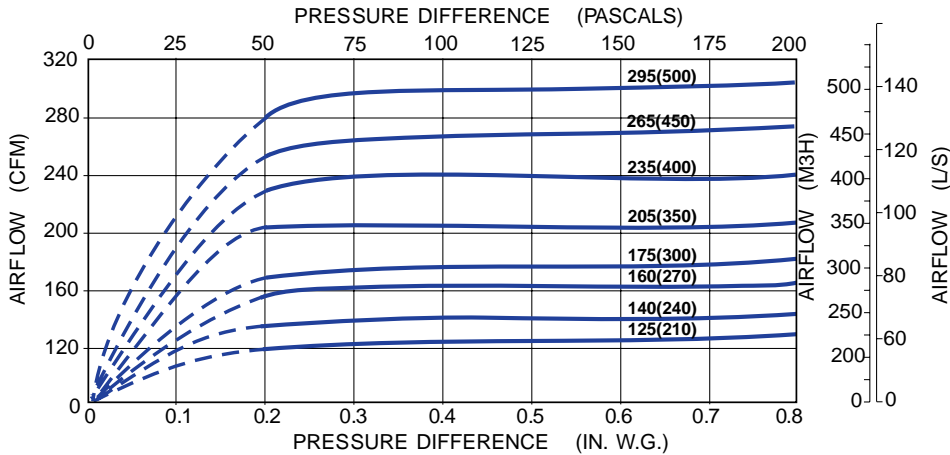

PART NUMBER	AIRFLOW
18 141	125 CFM (210 m ³ /h)
18 142	140 CFM (240 m ³ /h)
18 143	160 CFM (270 m ³ /h)
18 144	175 CFM (300 m ³ /h)
18 145	205 CFM (350 m ³ /h)
18 146	235 CFM (400 m ³ /h)
18 147	265 CFM (450 m ³ /h)
18 148	295 CFM (500 m ³ /h)

10" DIAMETER (250 mm) REGULATING ELEMENT

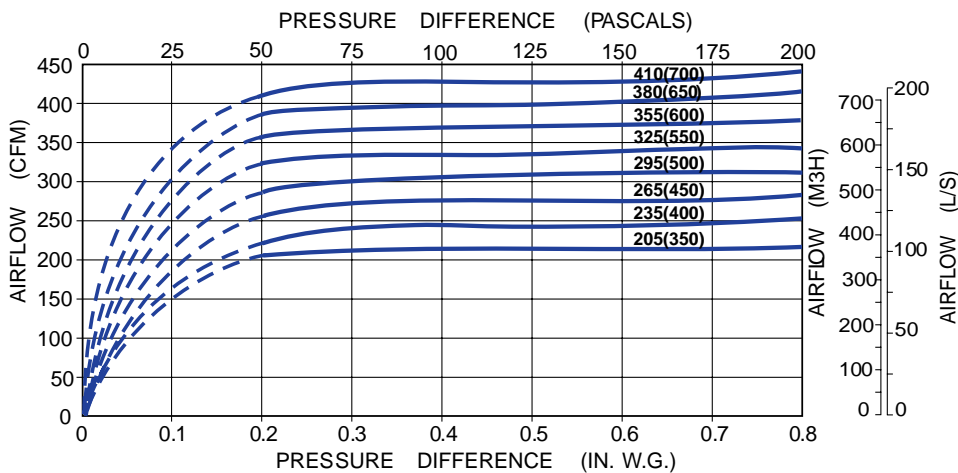

PART NUMBER	AIRFLOW
18 151	305 CFM (350 m ³ /h)
18 152	235 CFM (400 m ³ /h)
18 153	265 CFM (450 m ³ /h)
18 154	295 CFM (500 m ³ /h)
18 155	325 CFM (550 m ³ /h)
18 156	355 CFM (600 m ³ /h)
18 157	380 CFM (650 m ³ /h)
18 158	410 CFM (700 m ³ /h)

© 2013 American ALDES Ventilation Corporation. Reproduction or distribution, in whole or in part, of this document, in any form or by any means, without the express written consent of American ALDES Ventilation Corporation, is strictly prohibited. The information contained within this document is subject to change without prior written notice.



ROOF CAPS, WALL HOODS, GRILLES & DUCT FITTINGS

High-Performance Wall Hoods

With Screens or Gravity Dampers

PRODUCT SPECIFICATIONS & TECHNICAL DATA

DESCRIPTION

American ALDES High-Performance Wall Hoods are designed for use in exhaust or supply ventilation systems and fresh air kits. They are engineered to accommodate high airflow pressure and velocities found in premium fan and dryer vent systems. Wall hoods are available as screened or dampered versions. Each wall hood is designed to maximize airflow and minimize noise.

CONSTRUCTION

Wall Hoods are available in heavy-gauge G90 galvanized steel, 314 2B finish stainless steel, or solid copper type CA 110.

SCREENED WALL HOODS

1/4" galvanized steel mesh. Suitable for use in exhaust or supply ventilation systems and fresh-air kits.

DAMPERED WALL HOODS

For use in exhaust ventilation and dryer venting systems. A magnetic-catch damper ensures a tight closure when the fan is not running and eliminates damper flutter in windy conditions. These hoods should be used when backdraft dampers are not present at other locations within the duct system.

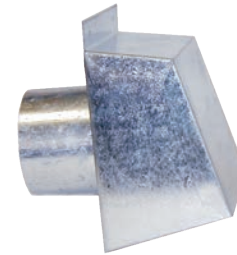

GALVANIZED STEEL



STAINLESS STEEL

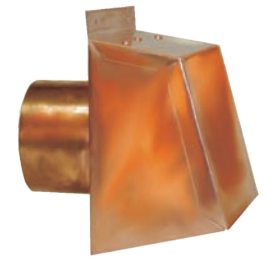

COPPER

Dimensional Data

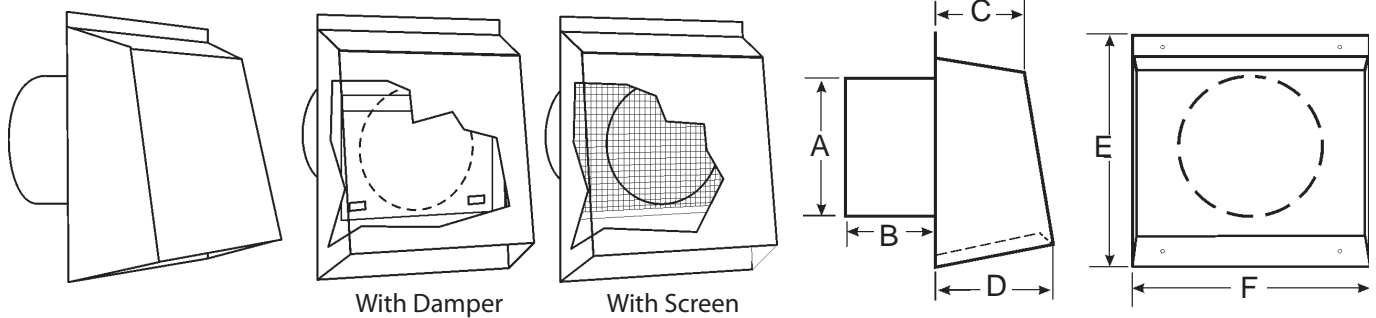

MODEL	Galvanized**		Stainless Steel		Copper		Dimensions					
	Dampered*	Screened	Dampered*	Screened	Dampered*	Screened						
Size	P/N	P/N	P/N	P/N	P/N	P/N	A	B	C	D	E	F
4"	22 404	22 304	22 404SS	22 304SS	22 404COP	22 304COP	4"	3"	3.0"	4.5"	8"	6"
5"	22 405	22 305	22 405SS	22 305SS	22 405COP	22 305COP	5"	3"	3.0"	5.0"	9"	8"
6"	22 406	22 306	22 406SS	22 306SS	22 406COP	22 306COP	6"	3"	4.0"	6.0"	10"	9"
8"	22 408	22 308	22 408SS	22 308SS	22 408COP	22 308COP	8"	3"	5.0"	8.0"	12"	11"
10"	22 410	22 310	22 410SS	22 310SS	22 410COP	22 310COP	10"	3"	6.5"	10.0"	14"	13"
12"	22 412	22 312	22 412SS	22 312SS	22 412COP	22 312COP	12"	3"	8.5"	12.0"	16"	15"

*For wall hoods with screens and backdraft dampers, add backdraft damper to screen model. See Backdraft Damper spec sheet for backdraft damper part numbers.

**Galvanized Steel Items (4" to 8" are 26 gauge; 10" and 12" are 24-gauge).

Materials: Galvanized Steel G-90, Copper Type Ca110, Stainless Type 314-2B Finish SMACNA GAUGE ACCORDING TO SIZE. Damper: Aluminum sheet, 0.020"

© 2013 American ALDES Ventilation Corporation. Reproduction or distribution, in whole or in part, of this document, in any form or by any means, without the express written consent of American ALDES Ventilation Corporation, is strictly prohibited. The information contained within this document is subject to change without prior written notice.