



MPVS100 & MPVS120

MULTI-PORT EXHAUST VENTILATORS

VENTERGY® SERIES FANS



*MPVS100 only

READ AND SAVE THESE INSTRUCTIONS

Product Description

Ventergy® Series Multi-Port Ventilators (MPVS) are highly versatile, continuous-duty rated fan units for residential and light commercial applications. The MPVS100 meets ENERGY STAR efficiency criteria for low-energy consumption. The most popular use is central, continuous exhaust ventilation of bathrooms, kitchens, laundry rooms, and other rooms where humidity is a controlling factor since the fan has a single exhaust discharge duct directly to the outdoors.

The principal advantage of the MPVS is the assurance of controlled indoor air quality ventilation and the elimination of standard noisy bath fans, with the benefits of reduced noise and fewer penetrations to the exterior of the building. With the increasingly tight construction of energy-efficient buildings, there is a growing need for mechanical ventilation for indoor air quality. These fans are designed to serve this purpose by providing effective bathroom ventilation with the ability to run intermittently or continuously. The quiet, energy-efficient, permanent-split-capacitor type of external-rotor motor has permanently sealed bearings that provide many years of maintenance-free performance.

Construction

The MPVS is constructed of heavy-gauge galvanized steel to prevent corrosion caused by moisture. The cabinet is internally lined with acoustic, closed-cell foam insulation that acts as a vapor barrier. This allows installation directly above living spaces or in unheated plenum spaces without concern for noise or condensation.

Controls

The fans can be operated manually or automatically by a programmable timer or dehumidistat. They may also be operated in conjunction with a variable speed control.

Ducting the Fan

The ducting from this fan to the outside of the building has a strong effect on the air flow, noise and energy use of the fan. Use the shortest, straightest duct routing possible for best performance, and avoid installing the fan with smaller ducts than recommended. Insulation around the ducts can reduce energy loss and inhibit mold growth. Fans installed with existing ducts may not achieve their rated airflow.

Use ductwork of a diameter that is the same as or greater than the diameter of the duct connectors on the fan.

Fan and Motor

The fan motor is an energy-efficient, permanent-split-capacitor type of external-rotor design. Totally sealed to protect against moisture and contaminants, it is approved for removing steam and moisture from kitchen and bath areas. The motor incorporates permanently lubricated and sealed bearings and automatic-reset thermal-overload protection. It is designed and certified for continuous duty or intermittent operation.

The fan uses a backward-inclined impeller design that prevents dust from collecting on the blades. Each fan is statically and dynamically balanced in the factory to eliminate vibration and ensure quiet operation. The entire motor and fan assembly is mounted on a drop-down hinged access panel for simple service and inspection, and it can be removed from the fan without disassembling the duct connections.

Locating and Installing

The compact dimensions and versatile mounting options permit installation above drop ceilings, between ceiling joists, or within a small soffit location. They can be installed horizontally or vertically.

Accessories

Accessory kits are available to facilitate installation and enhance operation. Accessories kits are sold separately. Please visit aldes-na.com, or contact your local Aldes distributor for details.

Performance

Fan airflow and energy performance shall be tested in accordance with HVI procedures.



*MPVS100 only

Dimensions & Performance

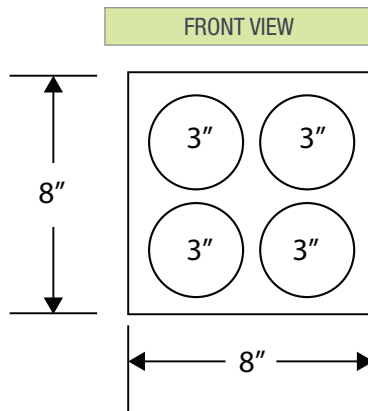
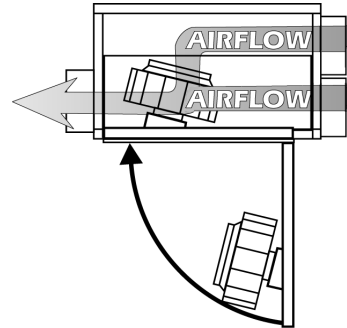
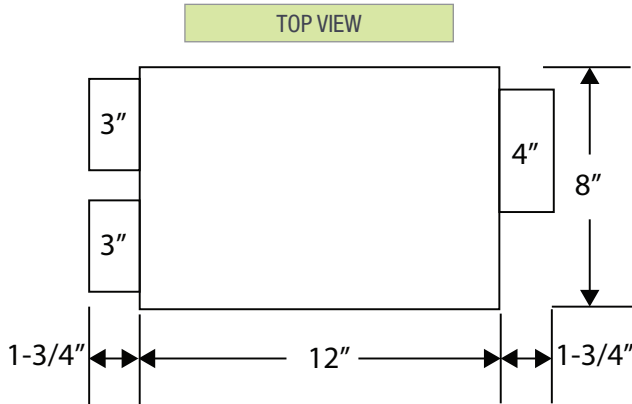

ELECTRICAL AND AIRFLOW PERFORMANCE*								
Model	Watts at 0.2" Ps	CFM vs. Static Pressure						ENERGY STAR Certified
		0.0"	0.2"	0.4"	0.6"	0.8"	1.0"	
MPVS100	20.8	108	88	68	48	25	--	√
MPVS120	37.5	143	128	111	95	74	45	

*Certified airflow rating at 0.2" w.g. is derated from actual test results per HVI Certification procedure 920. The HVI Certified Rate for MPVS100 = 80 CFM, MPVS120 = 120 CFM.

ELECTRICAL DATA
 MPVS100: 115 V, 60 Hz, 21 W, 0.19 A, 2500 RPM
 MPVS120: 115 V, 60 Hz, 34 W, 0.29 A, 3135 RPM
Above ratings are intended for sizing electrical wiring only. Actual consumption will be lower.

AIRFLOWS AND DUCT LENGTHS*

AIRFLOW CFM	3" INTAKE DUCT TO FAN Recommended Max. Duct Length from Grille to Fan (ft.)	
	SMOOTH	FLEXIBLE
10	225	180
20	65	50
30	30	25
40**	20	15
50**	10	10

TOTAL EXHAUST RATE CFM	FAN DISCHARGE DUCT Assumes low-pressure drop-vent cap		FOR EACH ELBOW DEDUCT
	4" SMOOTH	4" FLEXIBLE	
60	40 ft.	20 ft.	3" Diameter = 3 ft.
75	25 ft.	15 ft.	
90	18 ft.	12 ft.	
100	15 ft.	9 ft.	
120	11 ft.	8 ft.	
135	8 ft.	6 ft.	

*This table should only be used as a general guide. Actual duct length allowances may be longer on some models. Contact the factory for assistance.
 **Constant Airflow Regulators not available over 35 CFM. NOTE: If duct runs longer than permitted in the table above are required, use smooth ducting and/or increase the diameter.

REFERENCE RDF INSTALLATION SUPPLEMENT FOR ADDITIONAL INSTRUCTIONS AND WARRANTY INFORMATION.



*MPVS100 only

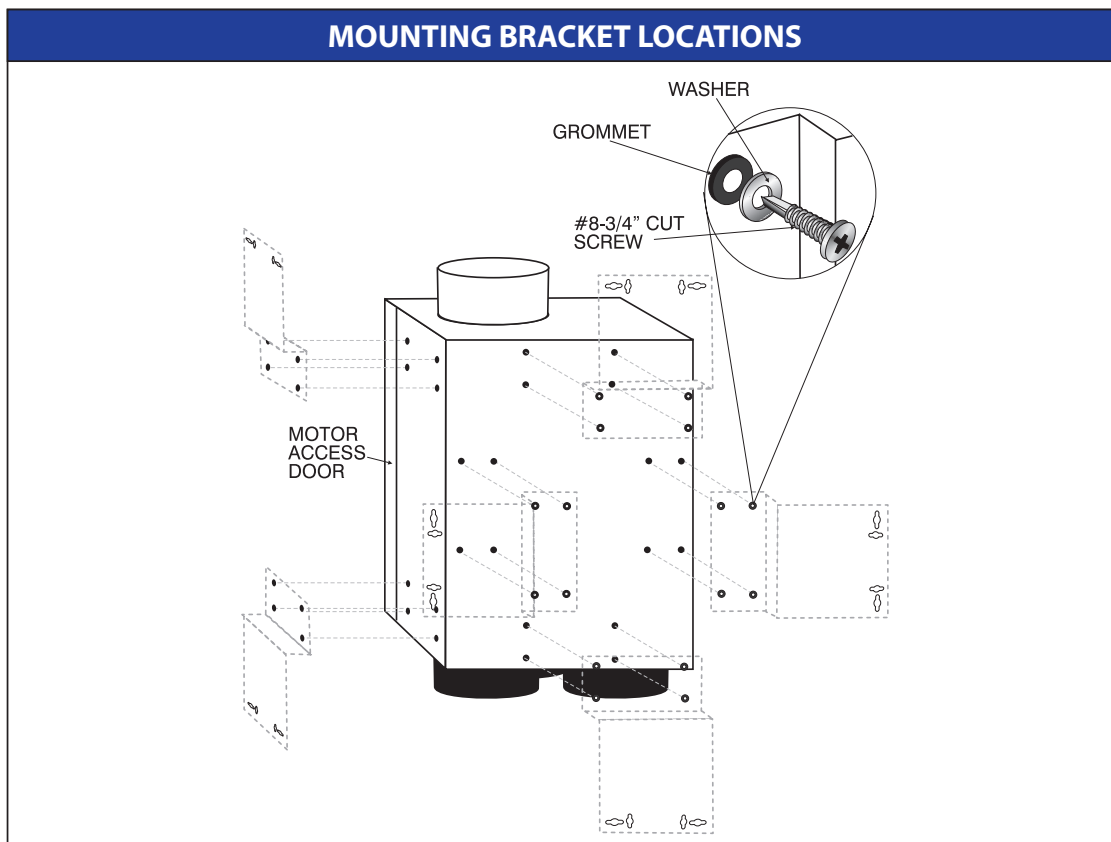
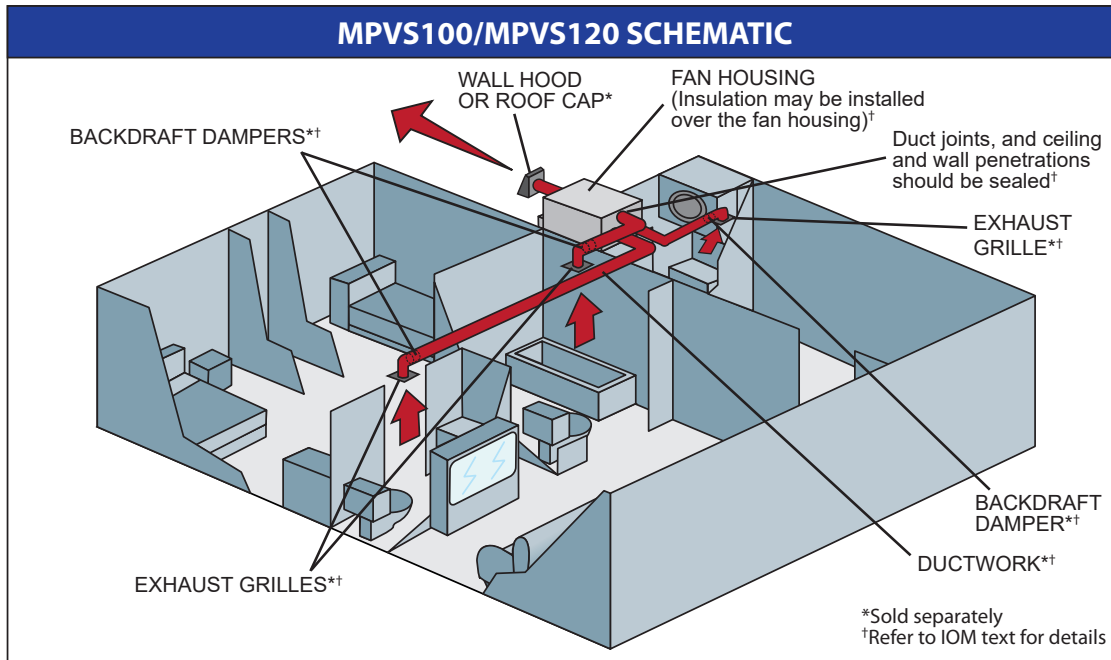

For more information, contact your Aldes sales advisor, visit aldes-na.com, call 1.800.255.7749, or find us on





RDF INSTALLATION SUPPLEMENT RECTANGULAR DUCT FAN

VENTERGY® SERIES FANS

IOM

READ AND SAVE THESE INSTRUCTIONS

For the following base models:

RDF 8-8IP, RDF 8-8MAX, RDF 12-8IP, RDF 12-8

(See supplemental instructions for derived models with duct adapters, manifolds, etc., as appropriate for your particular model.)

WARRANTY
3 YEARS

Installation

Upon receipt, inspect the carton to ensure the fan has not been damaged in transit. If damaged, it is the responsibility of the recipient to file a damage claim with the carrier. ALDES North America is not responsible for damage incurred during shipment.

Handle the unit with care to prevent damage to the housing and other components. Store the unit indoors if possible. If outdoor storage is required, protection against moisture and dirt is necessary.

Unpack the unit, taking care to look for any loose components among the packing material. Make certain that the fan housing and the blower are free of any loose packing material or small parts. If not removed before startup, damage and injury may result from solid objects discharged by the blower. Inspect for damaged, loose, or missing parts.

A location should be chosen that will minimize the length of duct runs and the number of elbows that are required. If more than four (4) 90° elbows are required, 45° elbows should be used. If insulated flexible duct is used, the inner sleeve should be fully expanded over the entire duct run. Any turns that are necessary in the flexible duct run should be made as gradually as possible. Choose roof and/or wall caps that are of a more open, less restrictive design. The perimeter of all ceiling and wall penetrations for ductwork and grille(s) should be properly sealed with caulk or a similar material to ensure that there is not an air leakage path between the device and the wall and/or ceiling.

Install the unit in its final location. The fan may be installed in a mechanical room, crawl space, or attic. It is designed to be placed on a flat surface, against a wall or trusses, or suspended from above. If set on a flat surface, vibration-isolation pads are recommended. Mounting brackets with rubber grommets are supplied to permit installation against a vertical surface or from the ceiling. Alternately, the fan may be suspended using threaded rods or chains. At least 12 inches clearance from the access panel is needed to permit servicing the motor. Loose fill or batt insulation can be installed over the unit if the unit's access doors can still be opened.

Mounting

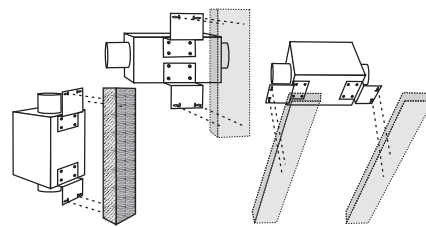

**FANS MAY BE
MOUNTED VERTICALLY
OR HORIZONTALLY**

(Differences in bracket type and configuration may exist on some derived models. Refer to supplement where appropriate). Orient the fan so that the access door can be opened for service.

Tools Required:

Power screwdriver with No. 2 Phillips bit.

Mounting brackets are supplied with the fan. The brackets may be mounted to the fan using the self-drilling screws and rubber grommets provided, at the locations indicated by dimple marks on the side and bottom panels of the fan. Pan head number 10 screws are provided to attach the mounting bracket to the building framing members. It may be necessary to add additional framing members to span wall studs. It is not recommended to use drywall anchors to support the fan. If installed against a concrete or masonry wall, concrete anchors are recommended. The rubber grommets provide vibration isolation. The brackets should be attached to the fan first. Then install the wood screws at the keyhole locations and install the fan.

The fan may also be mounted on a foam rubber pad on a flat surface, such as an attic floor.

Cold Climate Precautions

If installed in an unheated space in cold climates, there is a possibility of condensation forming in the fan housing or ducting components. A backdraft damper installed at each grille is an effective way to reduce the potential for condensation when the fan is cycled on and off. Insulated ducting must be used where exposed to cold attic or crawl space temperatures to avoid condensation in the ducting. Condensation can also be avoided by continuous operation of the fan.



Caution

FOR GENERAL VENTILATING USE ONLY. DO NOT USE TO EXHAUST HAZARDOUS OR EXPLOSIVE MATERIALS AND VAPORS.

Warning

TO REDUCE THE RISK OF FIRE, ELECTRIC SHOCK, OR INJURY TO PERSONS, OBSERVE THE FOLLOWING:

1. Use this unit only in the manner intended by the manufacturer. If you have any questions, contact the manufacturer.
2. Before servicing or cleaning the unit, switch power off at service panel and lock service panel to prevent power from being switched on accidentally. When the service disconnecting means cannot be locked, securely fasten a prominent warning device, such as a tag, to the service panel.

In addition to the following manufacturer's instructions, it is necessary to comply with federal, state, and local government codes. Your purchase of this ALDES North America system represents an investment in the health and comfort of occupants, as well as an investment in the protection of the building from the damaging effects of excessive indoor humidity.

This model of centrifugal fan is designed for multiple purposes. It may be used as an in-line rectangular duct fan (Model RDF) or a manifolded, multi-port fan for multiple exhaust or supply points. It may be installed in a remote location such as an attic space, mechanical room, above a drop ceiling, in a closet or in a laundry room, to provide quiet exhaust of stale, humid, or otherwise polluted air from bathrooms, kitchens, laundry rooms, or storage rooms via exhaust grilles and ducting to the centrally located fan, which is ducted to the outdoors. With small return grilles in bedrooms and other areas, and one duct connection to the outdoors, such as the BVS models, it may also be used as a supply ventilator or recirculating central ventilator for the introduction of outdoor air, raising the temperature of the fresh air by mixing with recirculated indoor air. When used with adjustable balancing grilles or ALDES Constant Airflow Regulators (CAR) and compatible roof/wall caps, ducting, etc., the fan is the heart of a complete pre-engineered ventilation system.

System Design

Satisfactory performance of a central ventilation system requires the proper integration of all the components:

- Fan selection for airflow, pressure and acoustic properties, vibration characteristics and mounting method, and mode of operation (continuous, manually or automatically controlled)
- Proper duct design for friction losses, with compatible supply or exhaust grilles (airflow and acoustic properties of the supply/exhaust grilles), and compatible wall/roof caps
- Method of balancing airflows of multi-point ventilation systems
- Consideration for potential condensation in the ducting or fan housing (installation in an unheated space)

Duct Connections

Ducting may be flexible or rigid, depending on local codes. If permitted by code, insulated flexible ducting is recommended. To limit fan noise, at least 8 feet of insulated flexible duct shall be installed between the fan and grille(s). All flexible duct connections shall be secured with clamps or wire ties and sealed with mastic or code-approved duct tape. All rigid ducts are to be sealed on both ends and along the longitudinal seams with mastic or code-approved duct tape.

Ducting should conform to NFPA 90A and meet the requirements of UL as a Class 0 or Class 1 duct to specification UL 181, Standard for Factory-Made Air Ducts and Duct Connectors.

Installation Warning

TO REDUCE THE RISK OF FIRE, ELECTRIC SHOCK, OR INJURY TO PERSONS, OBSERVE THE FOLLOWING:

1. Installation work and electrical wiring must be done by qualified person(s) in accordance with all applicable codes and standards, including fire-rated construction.
2. Sufficient air is needed for proper combustion and exhausting of gases through the flue (chimney) of fuel-burning equipment to prevent backdrafting. Follow the heating equipment manufacturer's guidelines and safety standards such as those published by the National Fire Protection Association (NFPA), the American Society for Heating, Refrigeration and Air Conditioning Engineers (ASHRAE), and the local code authorities.
3. When cutting or drilling into wall or ceiling, do not damage electrical wiring and other hidden utilities.
4. When used as exhaust fans, ducted fans must always be vented to the outdoors.
5. If this unit is to be installed over a tub or shower, it must be marked as appropriate for the application and be connected to a GFCI- (Ground Fault Circuit Interrupter) protected branch circuit.
6. NEVER place a switch where it can be reached from a tub or shower.

MAINTENANCE

MONTHLY: Inspect and clean the exhaust grilles and filters, if so equipped.

ANNUALLY: To ensure the maximum efficiency of the fan unit, it is recommended to clean the inside of the fan box as well as the blower wheel.

Electrical Data

Provide disconnect switch in vicinity of fan to permit servicing fan in accordance with NEC and local codes.

Depending on the desired mode of operation, switches may be simple on-off switches, motor speed controls, timer switches, time delay, time-of-day cycle timers, dehumidistats, occupancy sensing controls, controllers, etc., provided they are rated for the motor duty and meet the nameplate electrical ratings of the motor. (Additional application wiring diagrams illustrating a variety of controls for use with RDF fans are available by calling the factory at 1-800-255-7749.)

Base Model	Volts	Max Amps	Max Watts	RPM
RDF 8-8IP	115	0.19	20	2324
RDF 8-8MAX	115	0.29	34	3135
RDF 12-8IP	115	0.34	41	2200
RDF 12-8	115	0.53	59	2960

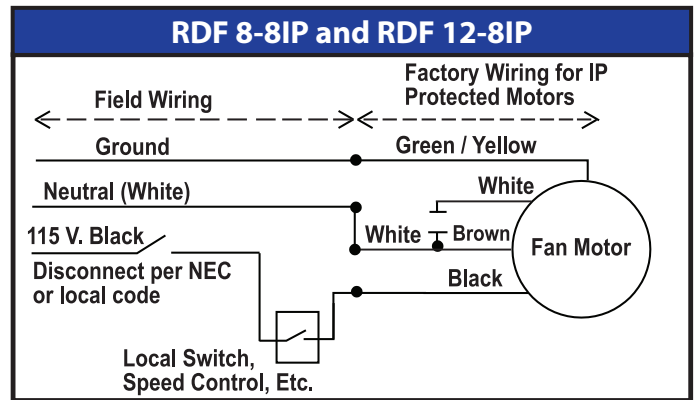
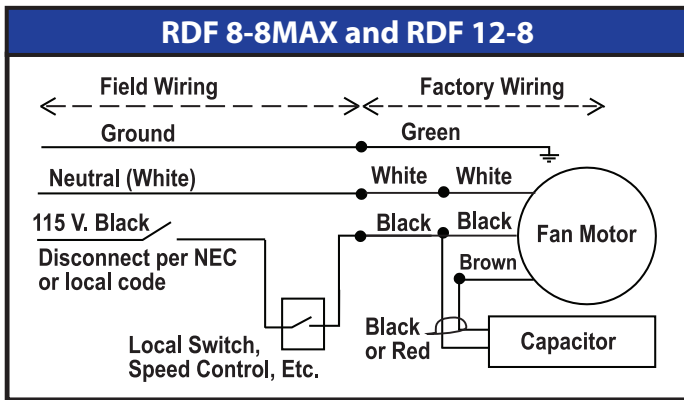

Disclaimer

IT IS THE RESPONSIBILITY OF THE CONTRACTOR/INSTALLER TO DETERMINE THE SUITABILITY OF THIS EQUIPMENT WITH RESPECT TO THE POTENTIAL FOR BACKDRAFTING NATURALLY VENTED FLUE DEVICES AND/OR AFFECTING RADON ENTRY.

Impact of Exhaust Fans

In especially tight homes heated with naturally vented appliances, such as gas, oil or wood-fired furnaces, boilers, stoves or fireplaces, the exhaust system may produce sufficient negative pressure indoors to induce the backdrafting of flue gases. This is a common, though intermittent, occurrence, with conventional exhaust systems, such as vented kitchen range hoods, clothes dryers, bath fans, etc. In the case of continuous exhaust, though often at lower flow rates, the potential for backdrafting the flue of these appliances does exist and represents a dangerous situation.

The International Fuel Gas Code, Appendix D provides a Recommended Procedure for Safety Inspection of an Existing Appliance Installation. This procedure should be followed to determine the presence of adequate combustion air while all exhaust fans are operating at maximum speed and all doors and windows are closed.

In the event that backdrafting occurs, steps must be taken to provide sufficient combustion air to the furnace or boiler, following the guidelines of the National Fuel Gas Code and all state and local codes.

Caution

AUTOMATICALLY OPERATED DEVICE. TO REDUCE RISK OF INJURY, DISCONNECT FROM THE POWER SUPPLY BEFORE SERVICING.

Disassembly

Turn off all power to the unit. The blower may be inspected and cleaned by removing the two screws from the hinged access panel. The blower assembly can now be swung open for cleaning the wheel.

For installations in which the fan is connected to a range hood, or if an exhaust grille connected to the fan is located near the cooking surface (as shown below), be sure to observe the following safety warnings:

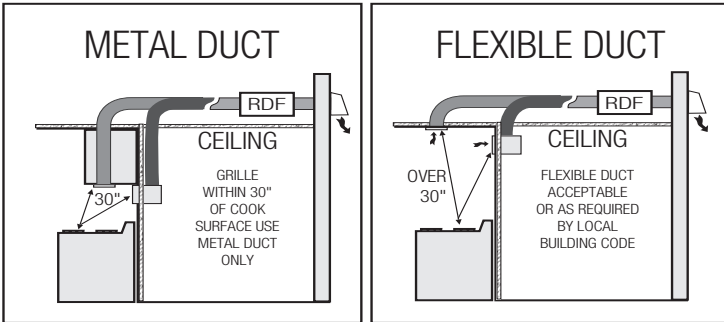

Warning

TO REDUCE THE RISK OF FIRE, USE ONLY GALVANIZED STEEL DUCTWORK WHEN REQUIRED TO USE METAL DUCT.

NOTE: If only rigid ducting is allowed, a metal sound attenuator shall be installed between the fan and the range hood.

NOTE: If the fan is not connected to a range hood or a grille in the vicinity of the cooking surface, other approved ducting may be used as described in the "Duct Connections" section of basic instructions.

Range Hood/Cooking Surface Warning

TO REDUCE THE RISK OF INJURY TO PERSONS IN THE EVENT OF A RANGE-TOP GREASE FIRE, OBSERVE THE FOLLOWING:

1. Never leave surface units unattended at high settings. Boilovers cause smoking and greasy spillovers that may ignite. Heat oils slowly on low or medium settings.
2. Always turn range hood ON when cooking at high heat or flambeing food.
3. Clean ventilating fans frequently. Grease should not be allowed to accumulate on fan or filter. Use proper pan size. Always use cookware appropriate for the size of the surface element.
4. **SMOTHER FLAMES** with a close-fitting lid, cookie sheet, or metal tray, then turn off the burner. **BE CAREFUL TO PREVENT BURNS.** If the flames do not go out immediately, **EVACUATE AND CALL THE FIRE DEPARTMENT.**
5. **NEVER PICK UP A FLAMING PAN** - You may be burned.
6. **DO NOT USE WATER**, including wet dishcloths or towels, because a violent steam explosion could result.
7. Use an extinguisher **ONLY** if:
 1. You know you have a Class ABC extinguisher, and you already know how to operate it.
 2. The fire is small and contained in the area where it started.
 3. The fire department is being called.
 4. You can fight the fire with your back to an exit.

Based on "Kitchen Fire Safety Tips" published by NFPA.

Mechanical Supply Fans

Mechanical supply of outdoor air tends to reduce the potential and frequency of backdrafting by reducing the contributing negative pressures; however, due to a multitude of factors, including the wide range of exhausting appliances that may be present, the effects of wind and building shape, the presence of multiple chimneys, building leakage, and the use of operable windows, no one can assure elimination of backdraft conditions so long as atmospherically vented combustion equipment is present in the home.

ALDES North America accepts no liability for backdraft conditions resulting from negative pressures. Nor does ALDES North America make representation that blending supply ventilators (BVS) are adequate to prevent such occurrences.

REPLACEMENT PARTS LIST (BASE MODELS)				
Model	Motor P/N	Impeller Dimensions (mm)	Capacitor	
			P/N	Cap
RDF 8-8IP*	86 561	133 x 42	86 172	4uF
RDF 8-8 MAX	86 561	133 x 45	86 172	4uF
RDF 12-8IP*	86 562	180 x 35	86 179	10uF
RDF 12-8	86 562	180 x 35	86 170	5uF

*Designates Impedance Protection with alternate wiring of capacitor across auxiliary winding of motor.



3 Year Warranty: This Warranty Supersedes All Prior Warranties

DURING THE FIRST 30 DAYS:

ALDES will repair or replace any product that has a factory defect in workmanship or material. Product(s) may be returned to point of purchase or the ALDES factory, with Bill of Sale, for an immediate replacement.

DURING THE FIRST 3 YEARS:

(Excluding the 30-day period above)
ALDES will repair or replace any product that has a factory defect in workmanship or material. Product(s) must be returned to the ALDES factory, with Bill of Sale and identified with an RMA number, within 3 years of purchase. The warrantee assumes all costs to and from the factory.

WARRANTY DOES NOT APPLY TO THE FOLLOWING:

1. Damages from shipping, either concealed or visible. Claim must be filed with the carrier.
2. Damages resulting from improper wiring or installation.
3. Damages or failure caused by Acts of God, or resulting from improper consumer procedures, such as:
 - Improper maintenance
 - Misuse, abuse, abnormal use, or accident
 - Incorrect electrical voltage or current
 - Removal or alterations made on the ALDES label, control number, or date of manufacture.
4. Any other warranty, expressed, written, or implied, and to any consequential or incidental damages, loss of property, revenues, or profit, or costs of removal, installation, or reinstallation, for any breach of warranty.

WARRANTY VALIDATION

The end user must keep a copy of the Bill of Sale to verify purchase date. Valid proof of the date of installation may also serve as a verification of commencement of warranty period.

ALDES RETURN POLICY

Claims for damages or order shortages must be reported within 10 days of receipt of product(s). For any product(s) received damaged by the forwarding agent, the following instructions MUST BE followed:

1. For product(s) delivered by UPS:
 - Concealed Damages: Keep all cartons; call UPS for an inspection and notify ALDES immediately.
 - Visible Damages: Save all cartons and file a complaint directly with UPS.
2. For product(s) delivered by Common Carrier: File damaged goods claim directly with the freight company.
3. Shortages: Only sign for the total number of pieces received and contact ALDES immediately.

FOR FACTORY RETURN

ALDES WILL NOT ACCEPT THE RETURN OF ANY SPECIAL, NON-STOCK, OBSOLETE, OR UNSALABLE PRODUCT(S). ALDES MAY, AT ITS DISCRETION, ACCEPT RETURN OF SALABLE PRODUCT(S) SUBJECT TO A 25% RESTOCKING CHARGE.

1. No product(s) will be accepted without a Return Materials Authorization (RMA) number. RMA number can be obtained by calling ALDES at 1-800-255-7749. Have the Bill of Sale or proof of date of installation available.
2. RMA must be clearly marked on outside of carton or delivery will be refused. All product(s) must be returned freight prepaid.
3. Product(s) will be repaired/replaced and shipped back to buyer; no credits will be issued.
4. Any out-of-warranty product will be evaluated and buyer will be notified of cost. Repair cost will be charged to customer. Buyer will be responsible for return freight, or product may be returned to the buyer, freight collect, without action. No credit will be issued.

LIMITATIONS OF WARRANTY AND LIABILITY

This warranty does not apply to any ALDES product or part which has failed as a result of faulty installation or abuse, incorrect electrical connections or alterations made by others, use under abnormal operating conditions, or misapplication of the product or parts. ALDES will not approve for payment any repair not made by us or our authorized agent without prior written consent. The foregoing shall constitute our sole and exclusive warranty and our sole exclusive liability, and is in lieu of any other warranties, whether written, oral, implied, or statutory. There are no warranties that extend beyond the description herein. In no event, whether as a result of breach of contract or warranty, or alleged negligence, defect, incorrect advice or other causes, shall ALDES be liable for special or consequential damages, including but not limited to, loss of profits or revenue, loss of use of equipment or any other associated equipment, cost of capital, cost of substitute equipment, facilities or services, downtime costs, or claims of customers of purchases for such damages. ALDES neither assumes nor authorizes any person to assume for it any other liability in connection with the sale of product(s) or part(s). Some jurisdictions do not allow the exclusion or limitation of incidental or consequential damages, so the above limitations and exclusions may not apply to you.

WARNING

ALDES products are designed and manufactured to provide reliable performance, but they are not guaranteed to be 100% free of defects. Even reliable products will experience occasional failures and this possibility should be recognized by the user. If these products are used in a life-support ventilation system where failure could result in loss or injury, the user should provide adequate back-up ventilation, supplementary natural ventilation, a failure alarm system, or willingly acknowledge the risk of such loss or injury.

For more information, contact your Aldes sales advisor, visit aldes-na.com, call 1.800.255.7749, or find us on

