

# PRODUCT: Butterfly Spring-Loaded Damper (BSD\_)

MATERIALS: Galvanized

SIZES: 4", 6", 8" & 10"



"A Tradition of Quality Since 1937"

Artis Metals Company

## PRODUCT HIGHLIGHTS

THE BSD BY ARTIS METALS IS A SPRING-LOADED INLINE BACKDRAFT DAMPER BUILT FOR A WIDE RANGE OF HVAC APPLICATIONS. IT CAN BE INSTALLED IN EITHER HORIZONTAL OR VERTICAL DUCT RUNS AND FEATURES A TIGHT-SEALING FOAM EDGE TO HELP REDUCE AIR LEAKAGE. ITS LIGHTWEIGHT ALUMINUM BLADES RESPOND EASILY TO AIRFLOW AND RETURN TO A CLOSED POSITION WHEN AIRFLOW STOPS.

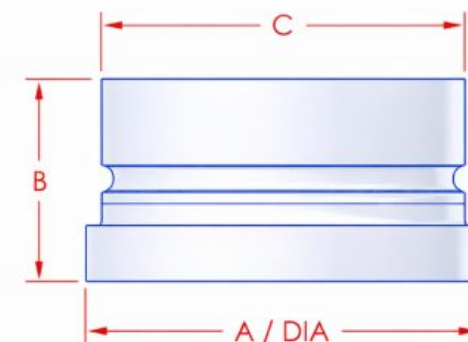
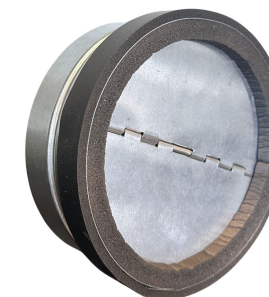
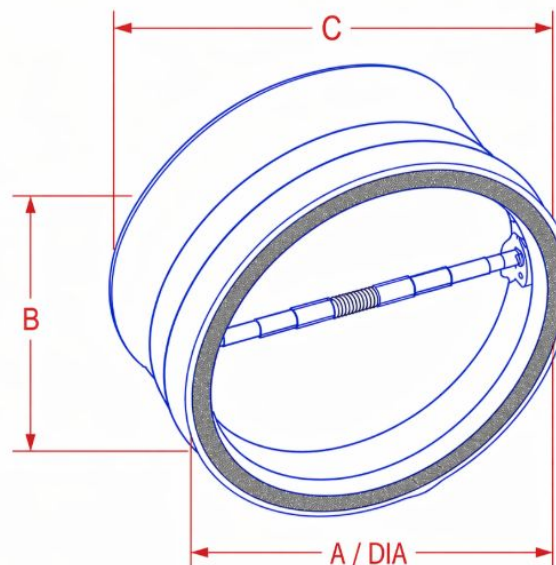

- SUITABLE FOR EXHAUST SYSTEMS, HEAT EXCHANGERS, SOLAR APPLICATIONS, AND FRESH AIR INTAKE
- OPERATES WITHOUT THE NEED FOR POWER
- DESIGNED TO SLIP EASILY INTO EXISTING DUCTWORK
- SELF-SEALING FOAM EDGE HELPS SECURE PLACEMENT
- QUICK INSTALL WITH MINIMAL MAINTENANCE REQUIRED
- INTERNAL FOAM GASKET FOR AIR TIGHT SEAL
- GALVANIZED CONSTRUCTION WITH ALUMINUM DAMPER & STAINLESS STEEL SPRINGS
- OUTER FOAM IS 3/16 INCHES WITH MEDIUM DENSITY FOAM
- INNER FOAM IS 3/8 INCHES WITH MEDIUM DENSITY FOAM

SKU	SIZE	A	B	C
BSD4	4"	3 5/8	2.12	4
BSD6	6"	5 5/8	2.125	6
BSD8	8"	7 5/8	2.125	8
BSD10	10"	9 5/8	2.15	10



3323 W Chinden Blvd, Boise, ID 83714  
Phone: (208) 336-1560 • Fax: 208-343-9679

[www.artiscaps.com](http://www.artiscaps.com)



PROUD MEMBER OF  
**HARDI**  
Heating, Air-conditioning & Refrigeration Distributors International

Copyright © Artis Metals HVAC  
Vent Manufacturer  
2019 All Rights Reserved