

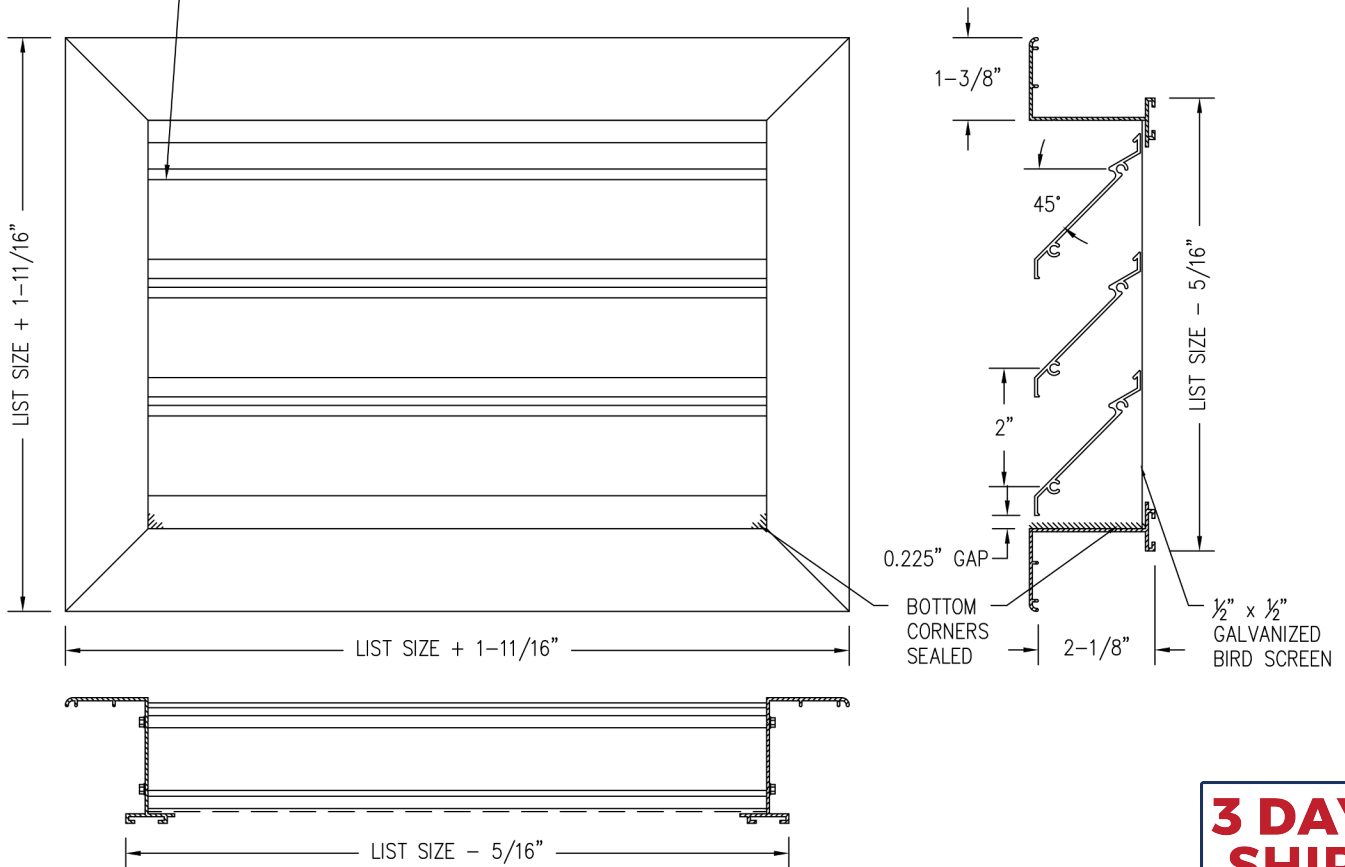

- Extruded storm proof blades designed to prevent water penetration and maximize free area.
- Heavy-duty aluminum extruded flange frame.
- Bird screen included standard. Insect screen can be specified.
- Mullions used for sizes over 36" in length.
- Available on 1" increments as standard. Custom sizes available down to 1/16" increments.
- Available with durable powder coat finish.

STORMPROOF BLADES ON 45° DEFLECTION AND 2" SPACING



Minimum height is 6"

Blade spacing may vary if height is not on 2" increment.



1. Specify the Length x Height Dimensions

Inches MM _____ x _____

Additional Options

IS - Insect Screen

A - Screw Holes

2. Select a Finish

W - White FB - Flat Black

S - Silver Special: _____

B - Brown

M - Mill

3. Select a Lead Time

3 Day Ship

Next Friday

Standard Delivery

Project / Location: _____

Architect: _____

Engineer: _____

Contractor: _____

