

Pro150

MAX CFM Bathroom Exhaust Fan

Product #: 98598



Ventilating fan should be ceiling or wall mounted and capable of exhausting air quietly and efficiently. The PRO 150 is HVI and ENERGY STAR certified. It comes with a capacitor start motor which is known for its high-efficiency and long lasting reliability. It holds an ETL listing and conforms to UL and CSA safety standards.

This fan has a unique plug and play concept that allows you to add a humidity sensor without changing the fan.

Features

- HVI and ENERGY STAR certified
- High efficiency capacitor start motor
- Plug and play concept
- 6" (152mm) Duct Connection
- Built-in back draft damper
- Corrosion resistance painted housing
- EZ Mounting bracket 14-24"
- Low profile grille
- Ceiling mount

Accessories

- Louvered Exhaust Shutter – HS Series
- Ceiling Radiation Damper – CRD Series

Specifications

- Duct size – 6" (152mm)
- Voltage/Phase/Hz – 120/1/60
- Power rated – 35 W
- Amp (Max) – 0.3 A

Requirements and Standards

- HVI Certified
- ENERGY STAR Certified
- ETL Listed
- ASHRAE 62.2 Approved
- CA Title 24



Description

Ventilating fan should be ceiling or wall mounted and capable of exhausting air quietly and efficiently. The PRO 150 series is HVI and ENERGY STAR certified. It comes with a capacitor start motor which is known for its high efficiency and long lasting reliability. It holds an ETL listing and conforms to UL and CSA safety standards. This fan has a unique plug and play concept that allows you to add accessories such as humidity sensor without changing the fan.

Housing

Corrosion resistant painted housing.

Detachable 6 inch round compatible collar which includes a light weight built-in back draft damper.

EZ mounting bracket that is adjustable up to 24 inch span allows for quick, ideal positioning.

Motor/Blower

Plug-in permanently lubricated motor - engineered for continuous operation.

The motor is energy efficient and surpasses the minimum ENERGY STAR requirements.

Power rating is 120 volts and 60 Hz.

Suitable for use over a bathtub or shower when installed with a GFCI protected branch circuit.

Motor is thermally protected to meet safety standards and increase motor life.

Our PRO series operates at lower RPM's to give you quieter operation.

Grille

The Premium grille is low-profile that has elegance and still able to maintain its simplicity.

Made of a rugged polymeric resin that's known for its long life durability.

Powerful torsion springs seat the grille tightly and evenly to the ceiling surface.

Optional

Humidity Sensor

Dimensions

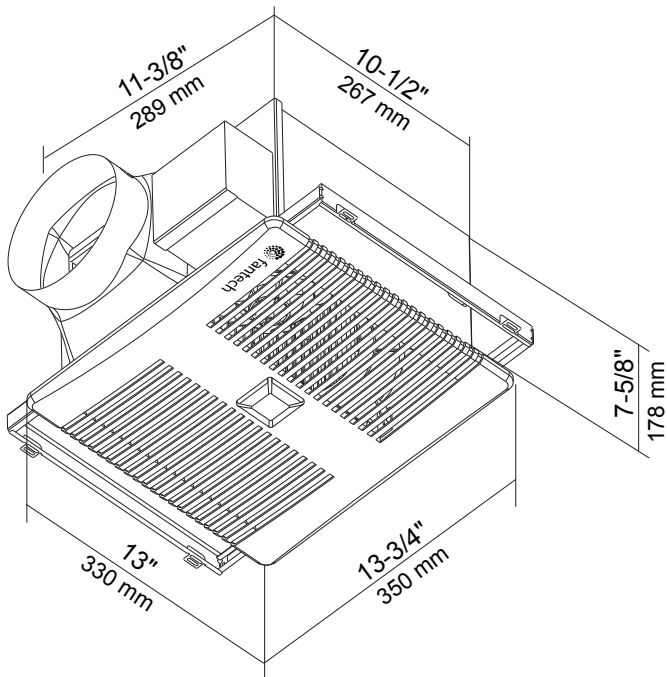

Ventilation Performance

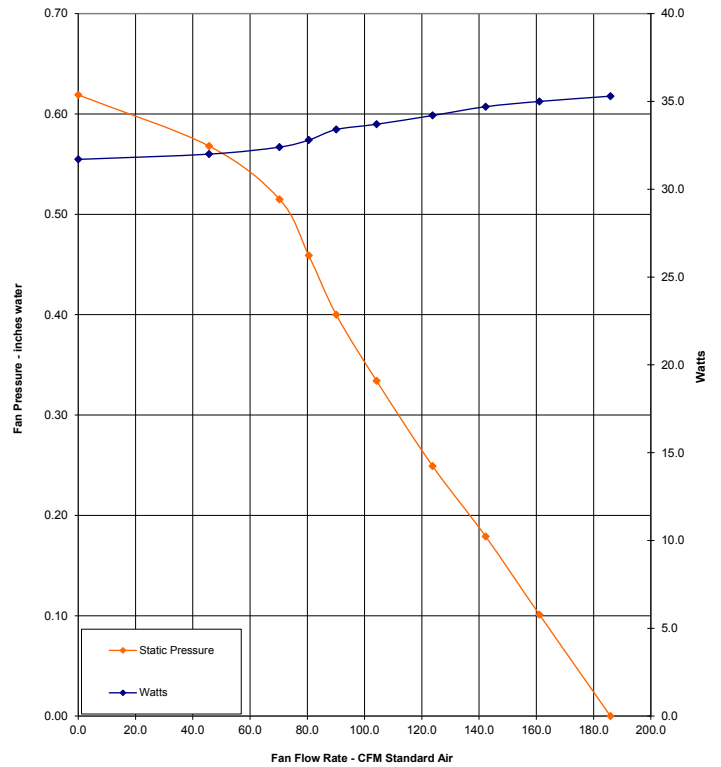

Contacts

Submitted by:	Date:
Quantity:	Model:
Comments:	Project #:
Location:	
Architect:	
Engineer:	Contractor:

Distributed by:

United States 10048 Industrial Blvd. • Lenexa, KS 66215 • 1.800.747.1762 • www.fantech.net
Canada 50 Kanalfakt Way • Bouctouche, NB E4S 3M5 • 1.800.565.3548 • www.fantech.net

Fantech, reserves the right to modify, at any time and without notice, any or all of its products' features, designs, components and specifications to maintain their technological leadership position.



fantech®
a systemair company