

ProPLUS(-L)

Ultra Quiet Bathroom Exhaust Fans with Humidity and Motion Sensors



Ultra quiet exhaust fans with humidity and motion sensors, which are ideal for bathroom and laundry rooms. Ventilating fans are suitable either for ceiling or wall mount and capable of exhausting air quietly and efficiently. The ProPLUS series is HVI and ENERGY STAR certified. It comes with a totally enclosed brushless DC motor technology which is known for its high efficiency and long lasting reliability. It holds an ETL listing and conforms to UL and CSA safety standards.

This fan is equipped with humidity and motion sensors.

Features

- HVI and ENERGY STAR certified
- High efficiency brushless DC motor
- Speed controllable: 80/90/110/140 CFM
- Ultra quiet - as low as .3 sones
- 6" (152mm) Duct Connection
- Built-in back draft damper
- Corrosion resistance painted housing
- EZ Mounting bracket 14-24"
- Low profile grille
- Ceiling or wall mount

Accessories

- Louvered Shutter – HS Series
- Fire Damper – FD Series

Specifications

- Duct size – 6" (152mm)
- Voltage/Phase/Hz – 120/1/60
- Power rated – 25 W
- Amp (Max) – 0.3 A

Requirements and Standards

- HVI & ENERGY STAR Certified
- ETL Listed
- Can be used to comply with ASHRAE 62.2
- CA Title 24



Housing

Corrosion resistance painted housing.

Detachable 6 inch round compatible collar which includes a light weight built in back draft damper.

EZ mounting bracket that is adjustable up to 24 inch span allows for quick, ideal positioning.

Motor/Blower

Plug in permanently lubricated motor - engineered for continuous operation.

The motor is energy efficient and surpasses the minimum ENERGY STAR requirements.

Speed control dial knob allows for easy fan speed selection adjustment from 80 to 140 CFM.

Electrical rating is 120 Volts and 60 Hz.

Suitable for use over a bathtub or shower when installed with a GFCI protected branch circuit.

Motor is thermally protected to meet safety standards and increase motor life.

Grille

The Premium grille is low-profile that has elegance and still able to maintain its simplicity.

Made of a rugged polymeric resin that's known for its long life durability.

Powerful torsion springs seat the grille tightly and evenly to the ceiling surface.

Humidity Sensor

The ProPLUS fan is equipped with a sophisticated humidity sensor that responds to: (a) rapid to moderate (user-adjustable) increases in humidity or (b) humidity above a user-adjustable set-point (50%-100%). Remains ON for a user-adjustable 5 to 60 seconds after humidity has stabilized and is below set-point.

Motion Sensor

The ProPLUS series is equipped with a motion sensor with multi-speed capability automatically turn the fan up to a maximum speed from the lower continuous setting when motion is detected. When someone leaves the room, fan will remain in high speed for a user adjustable (3-30 minutes).

Light

The ProPLUS-L model includes a 11W LED light at 800 lumens, 3990K, tested for more than 50K hours.

Dimensions

ProPLUS

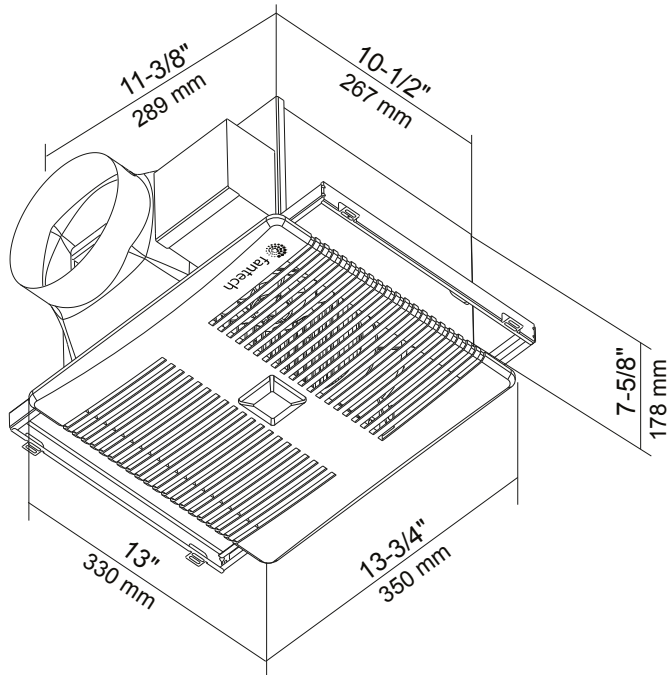

Ventilation Performance

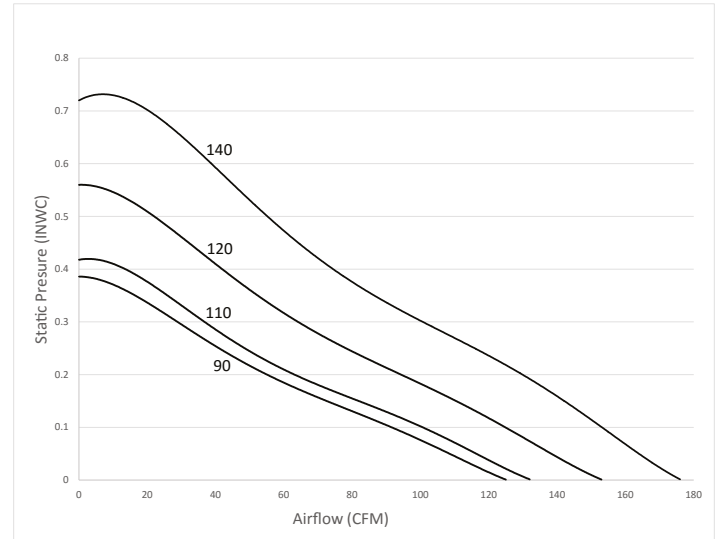

ProPLUS-L

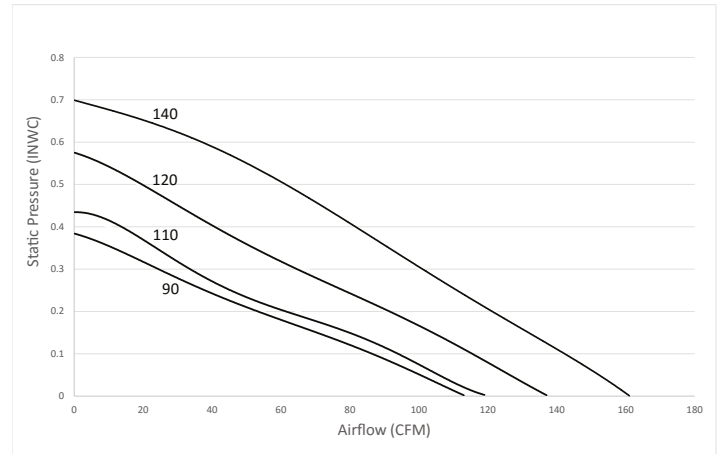
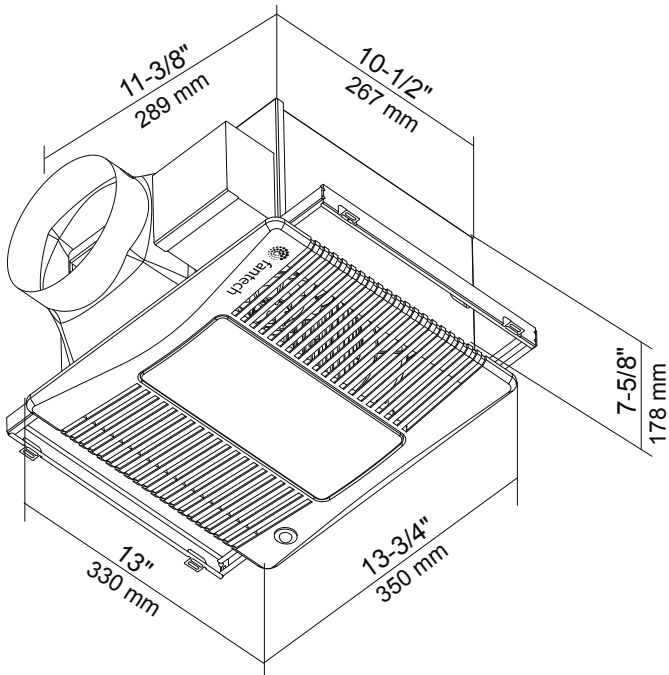

Contacts

Submitted by:	Date:
Quantity:	Model:
Comments:	Project #:
Location:	
Architect:	
Engineer:	Contractor:

Distributed by:

United States 10048 Industrial Blvd. • Lenexa, KS 66215 • 1.800.747.1762 • www.fantech.net
Canada 50 Kanalfakt Way • Bouctouche, NB E4S 3M5 • 1.800.565.3548 • www.fantech.net

Fantech, reserves the right to modify, at any time and without notice, any or all of its products' features, designs, components and specifications to maintain their technological leadership position.

