

NEW

CEPD SERIES

Ultra Quiet Ceiling Exhaust Fans with DC Motor



Canarm's ultra quiet CEPD fans come complete with high efficiency DC motors and are Energy Star approved. Built in speed controls are standard and allow for fine tuning CFM to your needs. Optional accessories are available such as a light kit or radiation damper, and a motion sensor and humidstat are available on special order.

FEATURES

- High performance and efficiency.
- Variable speed totally enclosed DC motor with thermal protection.
- Built in speed control.
- 6" Poly Collar with built in backdraft damper.
- Premium low profile poly grille.
- ETL listed for tub and shower when connected to a GFCI.
- HVI and Energy Star approved.

ACCESSORIES

- Light Kit
- Ceiling Radiation Damper
- Factory Options (Special Order):
 - Humidstat
 - Motion Sensor

PERFORMANCE SPECIFICATIONS

MODEL	STATIC PRESSURE (IN W.G.)	CFM	SONES	WATTS	POWER (V/Hz)	DUCT DIAMETER
CEPD150	0.1	150	0.9	12	120/60	6"
	0.25	130	1.4			
CEPD200	0.1	200	2.0	24	120/60	6"
	0.25	188	2.0			

DIMENSIONS

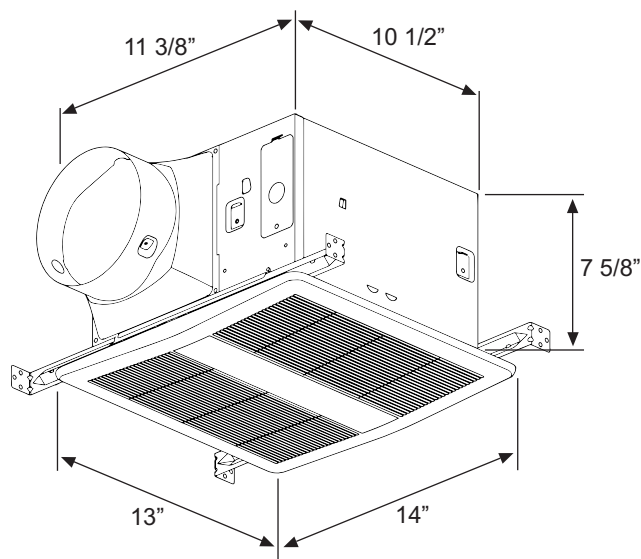

FAN CURVES

