

Model: SB

Dryer Vent

- Standard with Flapper Damper
- Large Free Area Reduce Clogging
- All Aluminum Construction

- Material: Aluminum
- Standard Finish: Clear Anodized

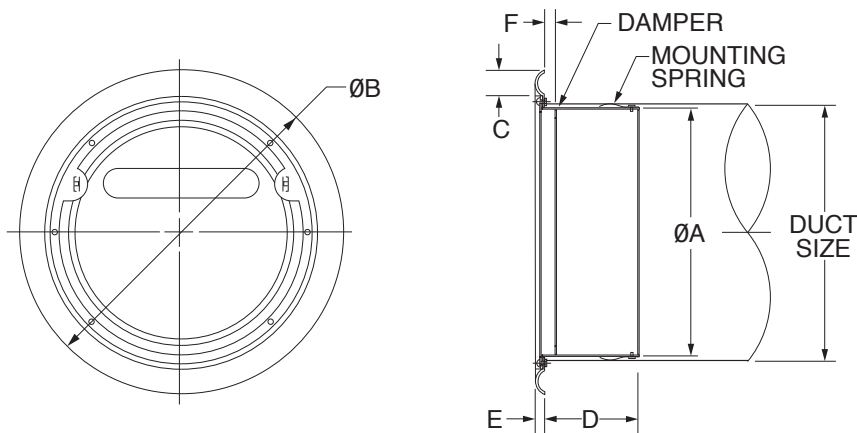

MODEL	DUCT SIZE	A	B	C	D	E	F	FREE AREA
SB 4	4"	3 19/16	5 23/32	19/32	1 21/32	9/32	TBA	TBA
SB 6	6"	5 23/32	8	25/32	2 3/4	9/32	3/4	0.14sq.ft

Product information is subject to change without notice. All dimensions in inches.

JOB NAME: _____
 LOCATION: _____
 ARCHITECT: _____
 ENGINEER: _____
 CONTRACTOR: _____

SUBMITTED BY: _____

DATE: _____

Model SB
 Dryer Vent

Form No.420-22