



Seiho International, Inc.

# SUBMITTAL SHEET

www.seiho.com

## Model: SFZC

Dryer Vent

- Standard with Backdraft Damper
- Large Vents Reduce Clogging
- All Aluminum Construction

- Material: Aluminum
- Standard Finish: Clear Anodized

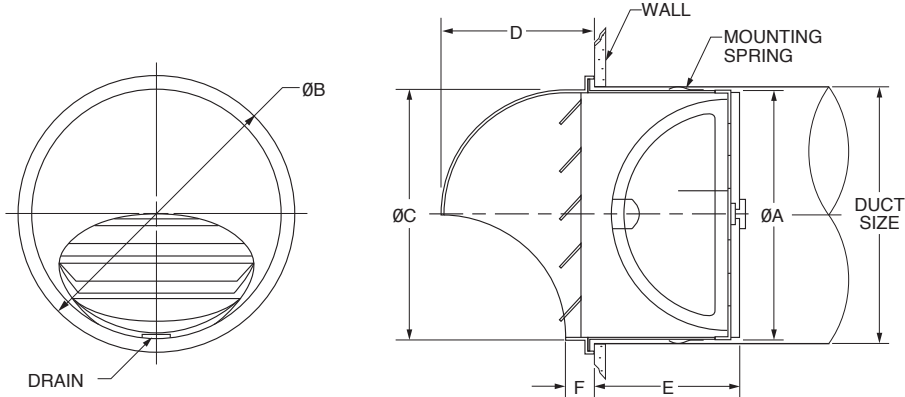

MODEL	DUCT SIZE	A	B	C	D	E	F	FREE AREA
SFZC 4	4	3 13/16	4 3/4	3 25/32	2 11/16	2 5/32	9/16	0.04
SFZC 6	6	5 23/32	6 29/32	5 29/32	3 15/16	3 3/4	3/4	0.13

Product information is subject to change without notice. All dimensions in inches.

JOB NAME: \_\_\_\_\_  
 LOCATION: \_\_\_\_\_  
 ARCHITECT: \_\_\_\_\_  
 ENGINEER: \_\_\_\_\_  
 CONTRACTOR: \_\_\_\_\_

SUBMITTED BY: \_\_\_\_\_

DATE: \_\_\_\_\_

**Model SFZC**  
 Dryer Vent

Form No.432-22