

iO-WR WIRELESS RELAY Installation, Operation Manual



REV 2

Introduction

The iO-WR wireless relay system consists of 2 units; an iO-WRBM-B Base Transceiver Module and an iO-WRSM Satellite Transceiver Module. The base transceiver is equipped with 3 digital input channels and 1 relay output channel. The satellite transceiver has 1 digital input and 3 relay output channels. The digital inputs are compatible with 24VAC HVAC systems. The outputs are switched through onboard relays. When properly installed and configured, the iO-WR system provides reliable wireless communication between two devices. Although the iO-WR has a line-of-site transmission distance of up to 100 feet, unimpeded communication between the two devices can vary depending on barriers created by interior and exterior walls and their material composition. The iO-WR communicates on the 915MHz frequency band and is certified and approved for use in the US, Canada, Australia and New Zealand. Each transceiver is equipped with a bi-color LED that is used to indicate its operational state. The transceivers also have a momentary pushbutton which is used to “pair” two units together, “unpair” previously paired units, or force a data transaction.

NOTE: The wireless relay transceivers are already factory paired and will begin to communicate once 24 volts is applied to each unit.

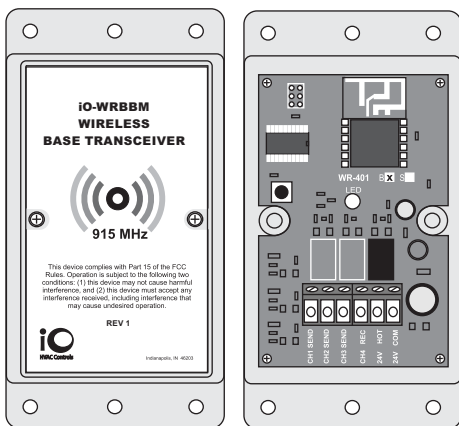

WR-401-B BASE
TRANSCIVER

ACCESS COVER
REMOVED

Installation

Both the base and satellite transceiver require continuous 24VAC.

iO-WRBM Base Transceiver Module

1. Mount the iO-WRBM Base Transceiver on a non-metallic surface in a location that allows access to the thermostat wiring at the indoor unit.

Do not mount inside the unit cabinet or inside any metal enclosure as this will greatly impede transmission distance.

2. Once the base transceiver is mounted, take the access cover off by removing the two screws. Refer to the iO-WRBM wiring diagram.
3. Use only 18-gauge solid (not stranded) thermostat wire. When connecting wires to the transceiver terminals, strip approximately 1/4" of insulation and push wire into designated terminal. Do not over-tighten the mounting screws.

TYPICAL WIRING FOR 3 HEAT / 2 COOL HEAT PUMP

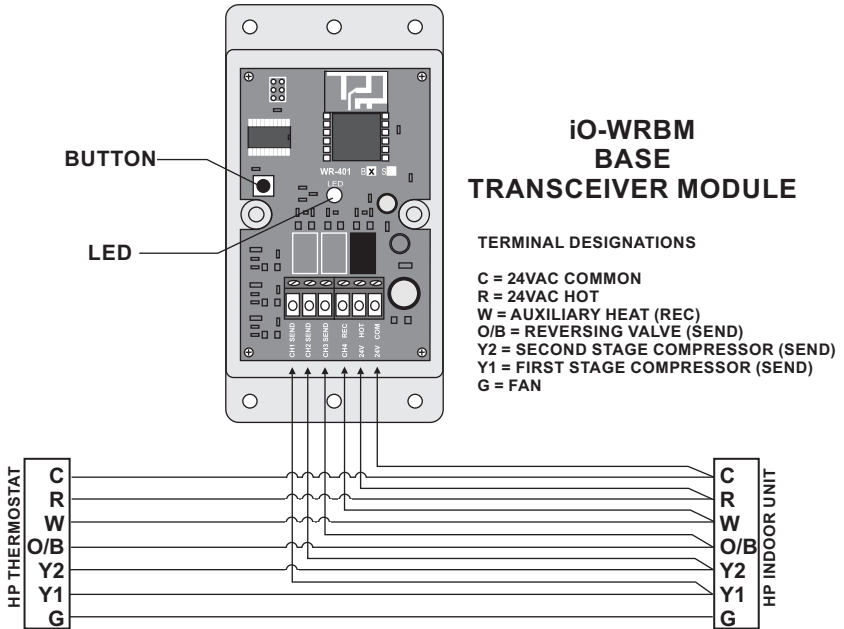

4. Make sure 2 VAC power is off before connecting wires to the base transceiver.

5. The wiring diagram above illustrates the use of all channels for a 3 heat / 2 cool heat pump system. Depending on the application, not all channels may be required.

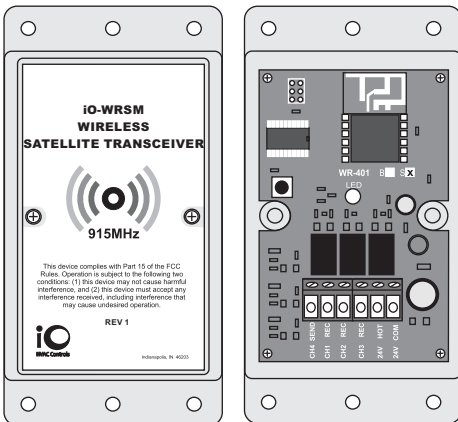

iO-WRSM Satellite Transceiver Module

1. The iO-WRSM Satellite Transceiver is mounted near the outdoor unit and should be installed with the wiring access hole at the bottom. The enclosure has a moisture-proof perimeter seal.

2. If 2 VAC is not available from the indoor unit, a transformer must be installed in the outdoor unit.

Refer to iO-WRSM wiring diagram.

3. When possible, mount the iO WRSM on a non-metallic surface close to the outdoor unit to facilitate ease of wiring.

4. Follow the same wiring procedure as used for the iO WRBM.

TYPICAL WIRING FOR 3 HEAT / 2 COOL HEAT PUMP

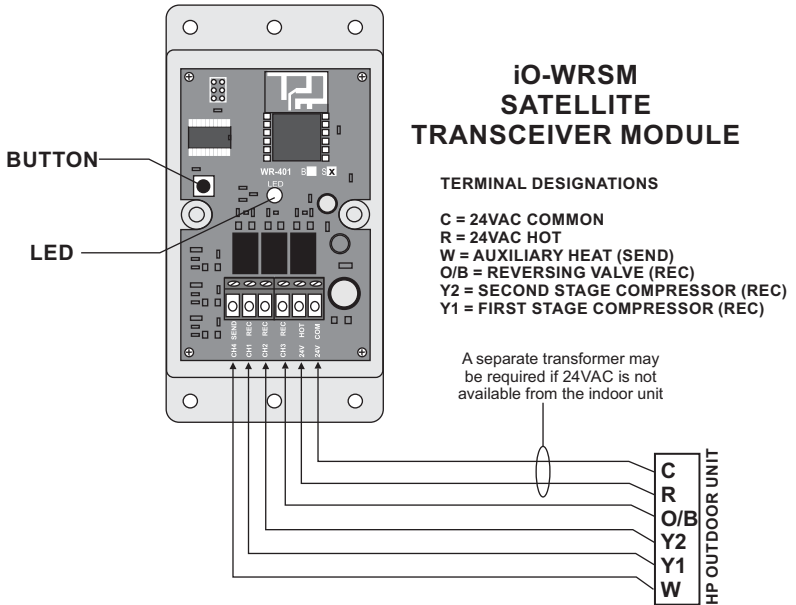

Pairing Transceivers

Since the transceivers have been paired at the factory, it is highly unlikely that they will require re-pairing. However, it may be necessary in the event one of the transceivers requires replacement.

1. After all wiring is performed, apply 24VAC to both the base and satellite transceivers.
2. The base transceiver LED will flash between red and green at a rate of 3 times per second. When in this mode, the base will broadcast a pair request message once every 5 seconds until it receives a pair response from the satellite transceiver.
3. The satellite LED will flash red every 3 seconds. Press and hold down the pushbutton on the satellite transceiver until it starts flashing red and green every 3 seconds. Once this pattern appears on the LED, release the pushbutton.
4. Pairing is confirmed when both transceiver LEDs go solid green. Once paired, the transceivers will poll each other every 15 seconds regardless whether any digital input signals are activated. The LEDs will flash red rapidly when a data message is received and go solid red when a data message is sent.

Note: When using multiple iO-WR-401 wireless relays in the same location, only power up one base and one satellite to be paired at a time.

Unpairing Transceivers

Unpairing a base and satellite transceiver is accomplished by holding down the button while applying 24VAC and continuing to hold the button down for about 5 seconds. While the button is held down, the LED will flash between red and green 5 times per second. Once the unpairing process is complete, the LED will flash as described in the pairing section. If the button is released prior to the completion of the unpairing process, the transceivers will transition to the paired mode, retaining their previous paired status.

Loss of Communications

Each transceiver has a built in inactivity timer to detect a loss of communications. If no data is received from a paired set for one minute, all outputs are turned off and the LED will display solid red.

LED Behavior in Paired Mode

Once paired, the transceiver LEDs should be on solid green between data commands or data response messages.

Solid Green - Last data transaction successful (within the last minute)

Solid Red - No reply from last data command message, or (satellite only) no data command message received in the last 60 seconds.

Flashing Red - Data reply message received.

RSSI (Receiver Signal Strength Indicator)

The iO-WR transceivers are equipped with an RSSI function that provides an indication of the receiver signal strength. The information is displayed on the LED each time a data message is received. The LED will flash 1 to 5 times. The more flashes, the stronger the signal. Once the red flashing is complete, the LED will display solid green.

Specifications

Power: 24VAC, 2.8VA
Channels: Base: 3 Send - 1 Receive Satellite: 3 Receive - 1 Send
Contact Rating: 1 Amp per channel
Frequency: 915MHz Operation
Range: Up to 100 ft.
Dimensions: 2-5/8" W x 5-1/8" H x 1-1/8" D

Compliance

The iO-WR Wireless Relay System has been tested and found to comply with the limits for a Class B digital device, pursuant to part 15 of the FCC Rules. These limits are designed to provide reasonable protection against harmful interference in a residential installation. This equipment generates, uses and can radiate radio frequency energy, and if not installed and used in accordance with the instructions, may cause harmful interference to radio communications. However, there is no guarantee that interference will not occur in a particular installation. If this equipment does cause harmful interference to radio or television reception, which can be determined by turning the equipment off and on, the user is encouraged to try to correct the interference by one or more of the following measures.

- Reorient or relocate the receiving antenna.
- Increase the separation between the equipment and receiver.
- Connect the equipment into an outlet or circuit different from that to which the receiver is connected.
- Consult the dealer or an experienced radio/TV technician for help.



HVAC Controls
Indianapolis, IN 46237

www.iohvaccontrols.com
For Technical Support Call Toll Free: 866-225-5032

iO-06-1282-061819