



DBF-100xp

Clothes Dryer Exhaust Booster Kit with Pressure Sensor Switch

Installation Instructions



This Premium Dryer Booster Kit Includes the following Components:

1. PV-100x Duct Boosting Fan (153 CFM)
2. Air Pressure Sensing Switch with electronic cycle timing board
3. Fan Mounting Bracket

U.S. Distribution Center

Soler & Palau USA
6393 Powers Avenue
Jacksonville, FL 32217

Phone: 800.961.7370
Fax: 800.961.7379

www.solerpalau-usa.com

Important Notice: Read and Save these instructions for future reference.

DVF-100xp Clothes Dryer Exhaust Booster Kit Installation Instructions

Installation Guidelines

Important notice! To prevent the possibility of dryer fan exhausting excess heat required for the drying cycle and compromising drying times, booster fan airflow must not exceed the dryer fan capacity.

INSTALLATION WARNING: TO REDUCE THE RISK OF FIRE, ELECTRIC SHOCK OR INJURY, OBSERVE THE FOLLOWING:

- (a) Use this unit only in the manner intended by the manufacturer. If you have any questions contact the manufacturer.
- (b) Before servicing or cleaning the unit, switch the power off at the service panel and lock the service disconnecting means to prevent power from being switched on accidentally. When the service disconnecting means cannot be locked; securely fasten a prominent warning device such as a tag to the service panel.
- (c) Installation work and electrical wiring must be done by qualified person(s) in accordance with all applicable codes & standards including fire related construction.
- (d) When cutting or drilling into wall or ceiling, do not damage electrical wiring and other hidden utilities.
- (e) Ducted fans must always be vented to the outdoors.
- (f) CAUTION: For General Ventilating Use Only. Do Not Use To Exhaust Hazardous Or Explosive Materials And Vapors.
- (g) CAUTION: This unit has an unguarded impeller. Do Not Use In Locations Readily Accessible To People or Animals.
- (h) DO NOT USE with heated air in excess 140°F (60°C).

Fan and Switch Mounting

It is recommended that the booster fan is mounted in the ductwork not less than 15 feet from the exhaust outlet of the dryer. Installation of the fan closer than the recommended 15 feet may allow enough pressure to lift wet lint into the fan impeller. This can result in excessive lint loading in the fan and drastically affect performance and can restrict the performance of the system. The best location for the fan to be mounted is as close as possible to the desired 15 feet from the dryer's exhaust outlet. (Exception: If a secondary lint filter is installed between the dryer and the booster fan, the booster fan may be mounted within the minimum distance otherwise recommended. The supplied mounting bracket attached to a rafter or joist should be used to stabilize the fan. (Consult local codes prior to supporting the fan in the duct alone if rafter or joist is not available to secure the fan.) Duct work should be attached to the inlet and outlet of the fan by means of FC vibration isolation clamps (not included) or duct tape. The duct connection should be properly sealed to prevent leakage and loss of fan performance. It is recommended to maximize performance that rigid duct is utilized. If flexible duct connections between the dryer duct connection and exhaust duct are utilized, the duct should be stretched as smooth as possible.

Pressure Sensor Switch Operation

The DVF-100xp dryer booster kit that you have selected is supplied with a premium air pressure sensing switch. The pressure sensor is set by the manufacturer and recognizes the positive pressure generated by the clothes dryer fan operation. The sensor identifies dryer operation and activates the booster fan, which is mounted on a separate electrical circuit. The booster fan is set to run for 10 minutes and then to stop for 15 seconds. If the sensor recognizes continual operation of the clothes dryer, it reactivates the booster fan for another 10 minute interval. If it does not recognize positive pressure generated by the clothes dryer, the booster fan remains off until the next dryer cycle is started.

DVF-100xp Clothes Dryer Exhaust Booster Kit Installation Instructions

Fan Installation

Step 1. Select Booster Fan Location

Where booster fans utilizing pressure sensors are limited in their installation, the PV-100x dryer booster kit with pressure switch that you have selected can be mounted in any orientation, allowing you more flexibility in selecting a location that is easily accessed for preventative maintenance. When selecting the location for your booster fan, remember the guidelines indicated in the Fan and Switch Mounting instructions. **See Illustration I-6 on page 6.**

Step 2. Mount Fan Bracket

Using the supplied mounting bracket, attach to a support rafter or joist at the selected location.

Step 3. Mount Fan to Bracket

With Bracket firmly secured to joist or rafter, attach the PV-100x fan to the bracket.

Illustration I-3 - Air Pressure Sensing Switch

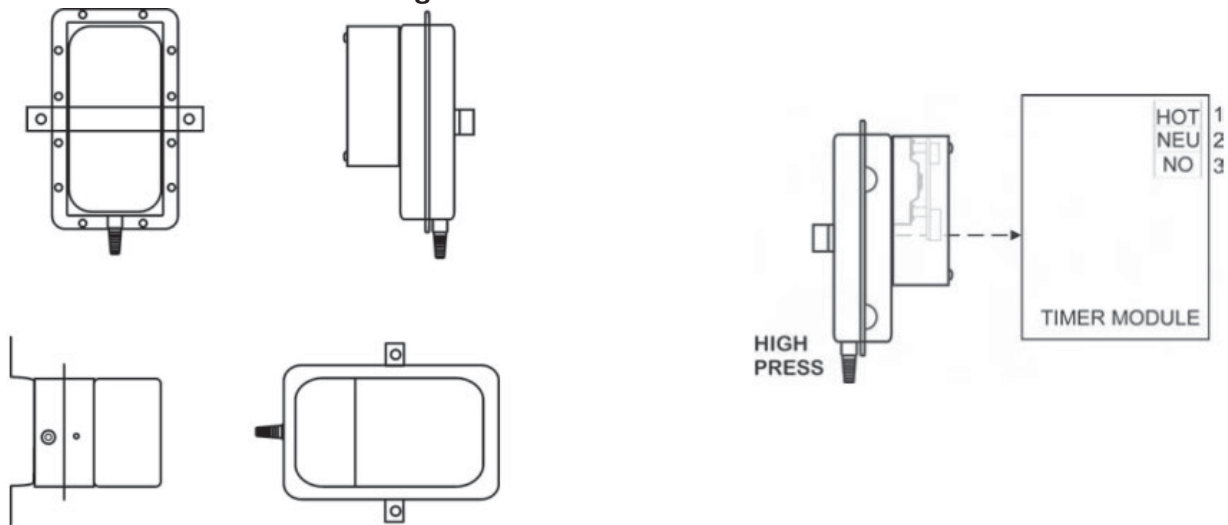

Mount with the diaphragm in any vertical plane.

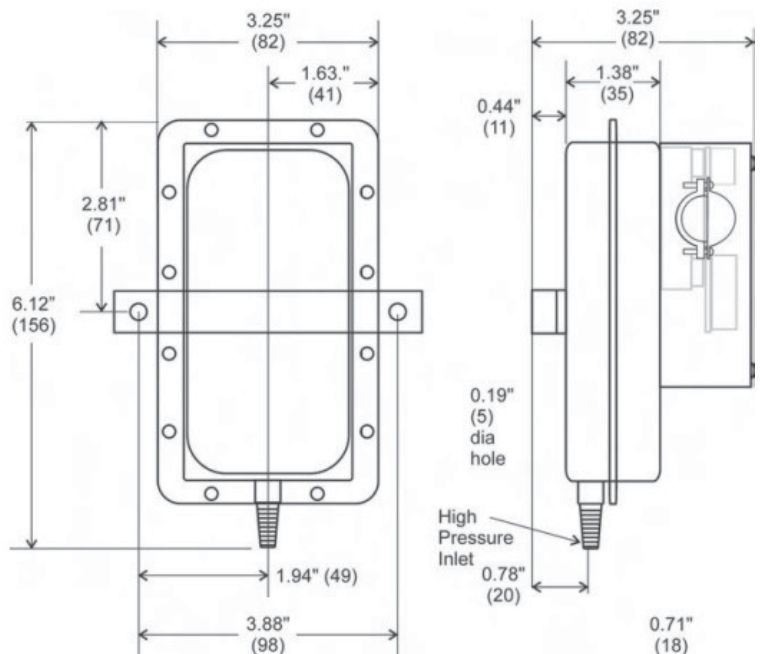
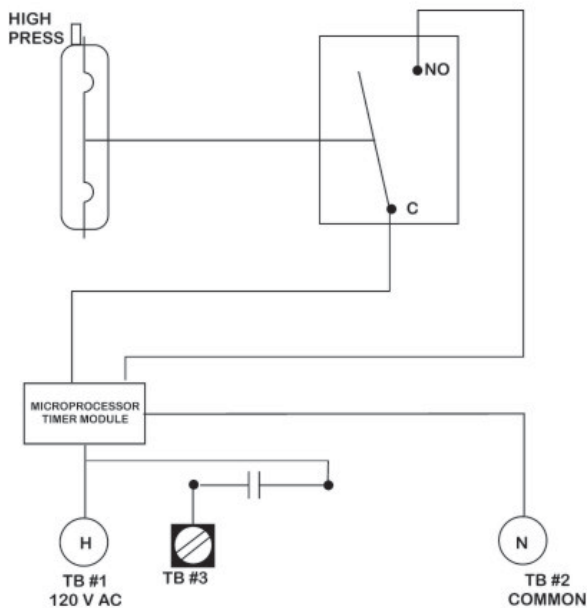

DVF-100xp Clothes Dryer Exhaust Booster Kit Installation Instructions

ELECTRICAL CONNECTION

All POWERVENT series fans operate from a standard 120V 60Hz A.C electrical supply. All wiring must be carried out in accordance with National Electrical Code, and all applicable state and local buildings codes.

Electrical connections should be made in accordance with the electrical wiring diagrams shown in **Figure (3) Electrical Wiring on page 5**.

Wiring Procedure

Make sure that source power is disconnected from both dryer and fan!

All fan motor connections are prewired to an electrical terminal strip. A $\frac{3}{8}$ " romex type cable restraint connector will be needed to secure the wiring through the knockout provided on the side of the terminal box.

Step 1.

Remove the cover, which is held in place with 2 phillips head screws. Bring romex from the source and romex to the fan through the cable restraint and secure. Connect Source HOT (Black) to 1, Source and Fan Supply Neutral to 2, and fan HOT (Black) to 3. Secure both grounds to the ground lug inside switch cover and reconnect the cover to the switch. (It is advised to utilize an approximately 3" jumper to connect neutral wires.)

Figure 2 - Pressure Sensor Switch

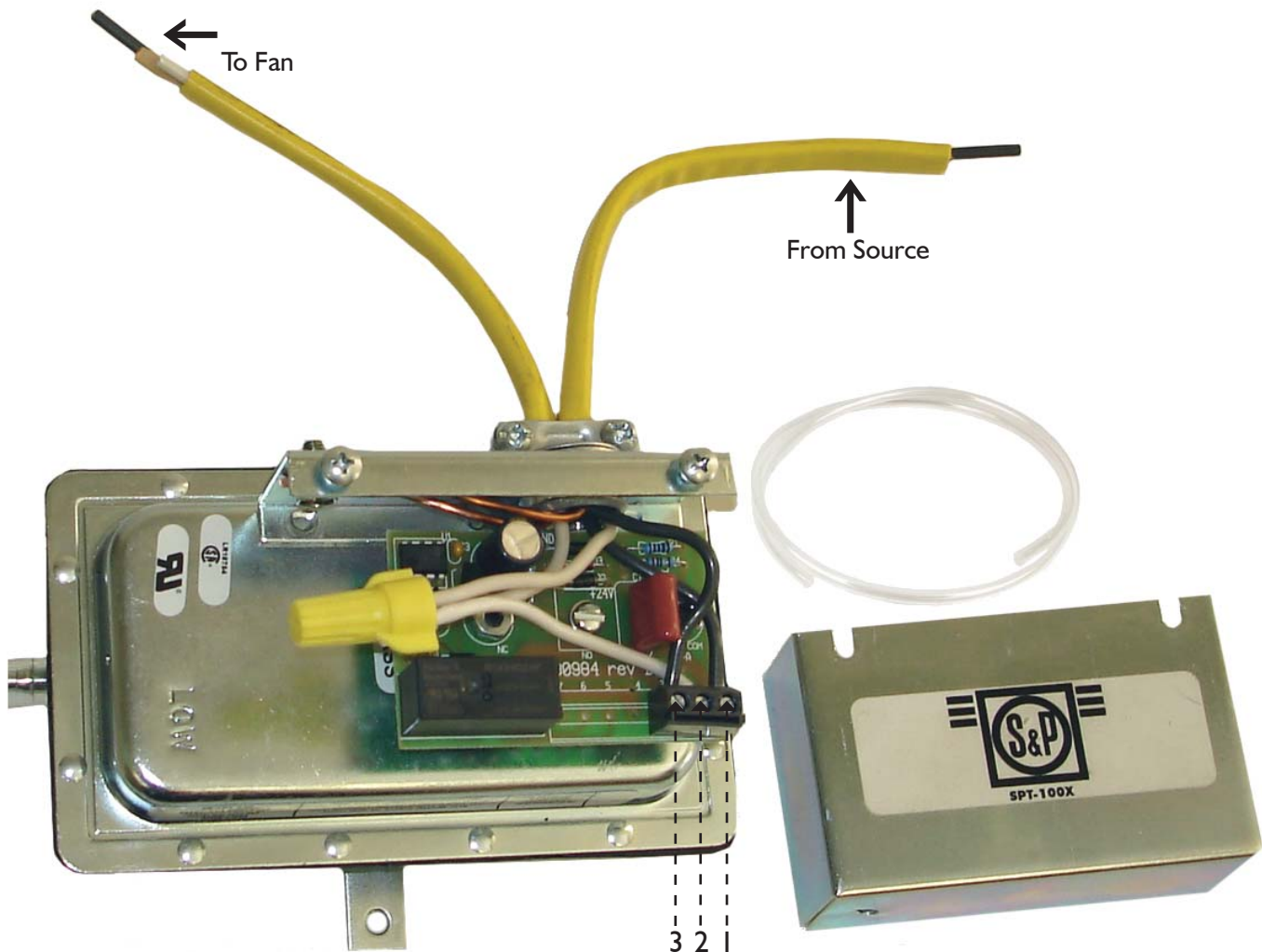

DVF-100xp Clothes Dryer Exhaust Booster Kit Installation Instructions

Step 2.

Remove the screws securing the terminal box cover plate of the PV-100x. Bring incoming electrical connections through the romex connector and through the terminal box knockout. From the pressure sensor NO (Normally Open) position (#3), connect to Supply (L) as shown in figure below. Connect common and ground from the switch as indicated below:

Figure 3 - Electrical Wiring

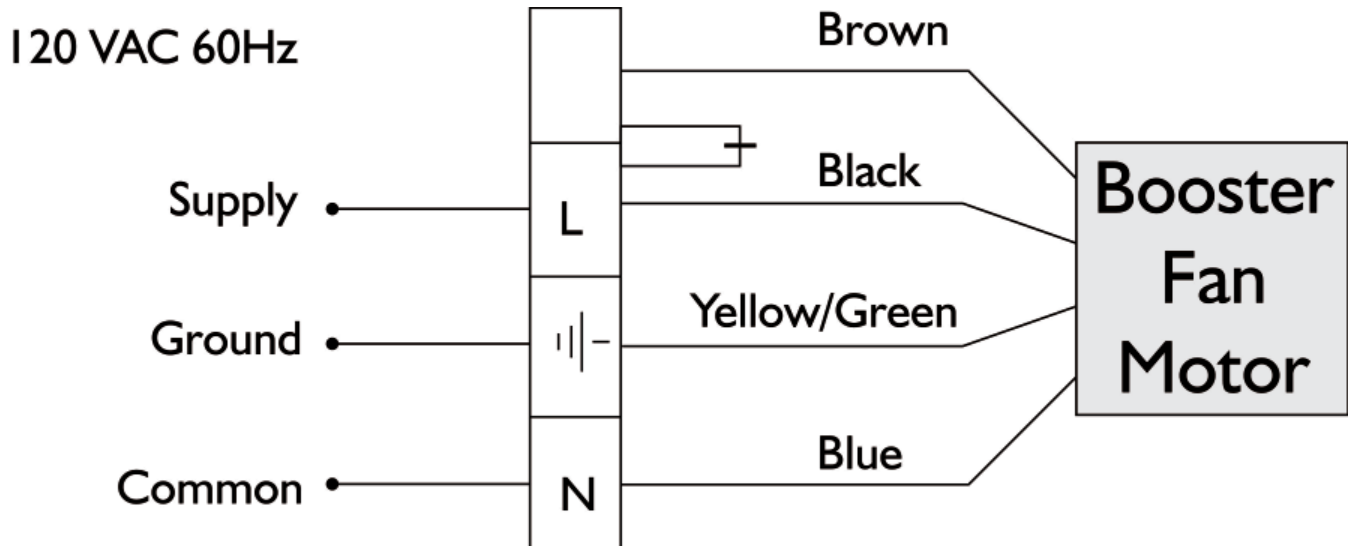

Step 3.

Check all connections and secure the incoming supply with the romex connector. Replace the fan terminal box cover.

Recommended Preventative Maintenance

1. Since fan bearings are sealed and provided with an internal lubricating material, no additional lubrication is necessary.
2. Fan impeller may accumulate lint. Periodic inspection, based upon dryer usage, should be performed to ensure that the fan impeller is not obstructed or loaded with lint. Under normal conditions, fan should be inspected at least once every six months (more often if usage is high).

Excessive booster fan noise or vibration may be an indication of lint buildup on the impeller. To inspect and clean the impeller:

- a. Disconnect the incoming power supply at the source of the Fan.
- b. Remove the duct from the fan inlet and remove any lint buildup on the impeller.
- c. Reconnect the duct to the fan. Turn power supply on.

DVF-100xp Clothes Dryer Exhaust Booster Kit Installation Instructions

Illustration I-6 - Fan and Switch Mounting

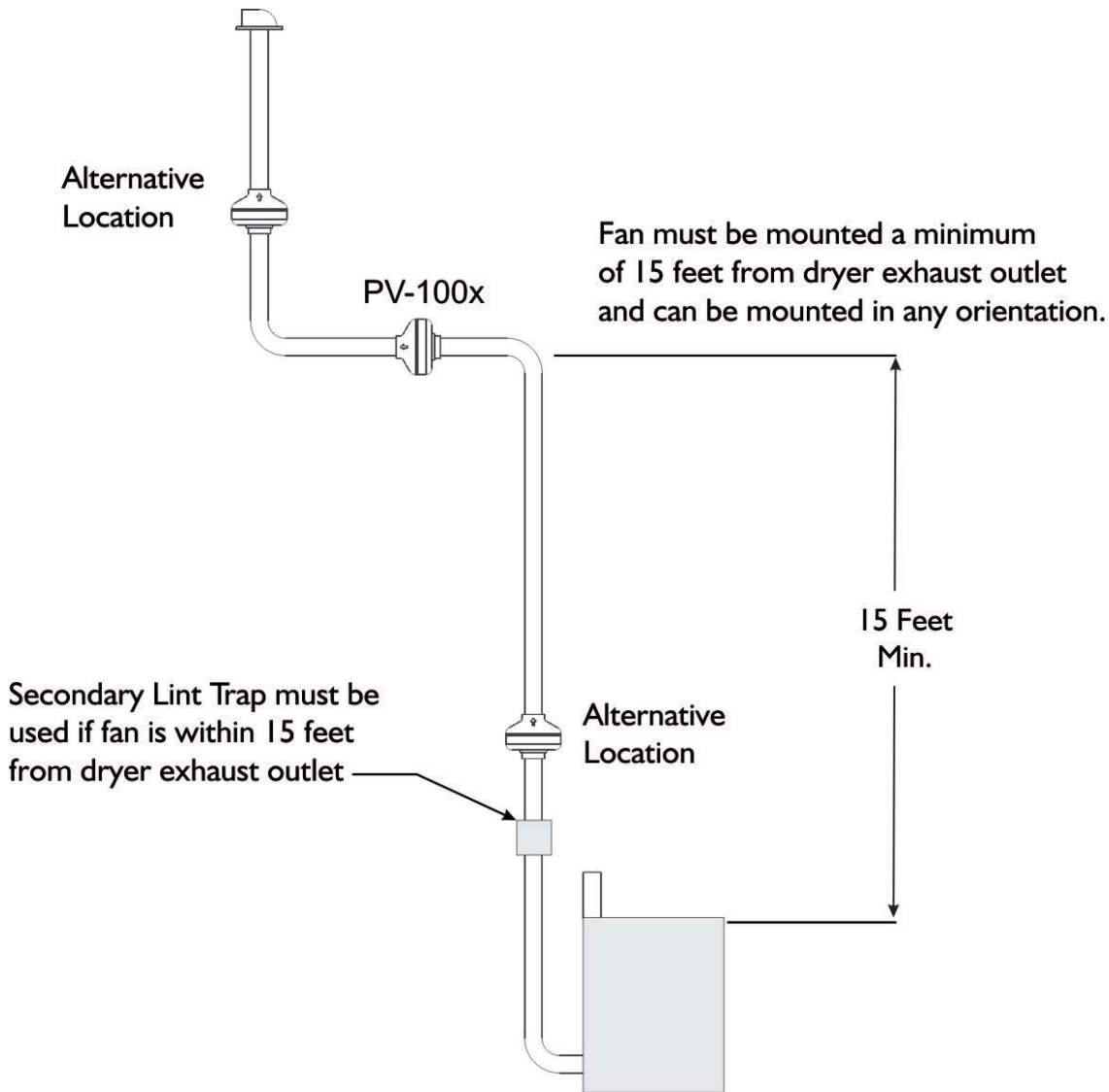

Dimensional Data

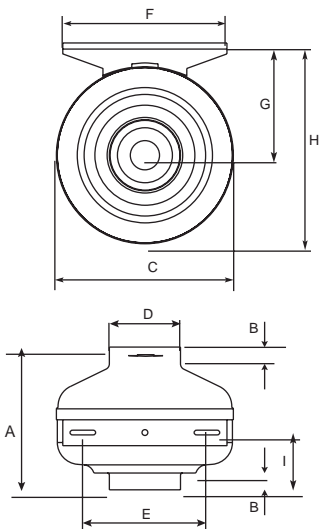

Model	A	B	C	D	E	F	G	H	I	Weight lbs(kgs)
PV-100	7 5/8 194	1 25	9 1/2 241	3 7/8 98	6 11/16 170	8 7/8 225	6 1/16 154	10 13/16 275	3 1/4 83	7 3.0
PV-100x	7 5/8 194	1 25	9 1/2 241	3 7/8 98	6 11/16 170	8 7/8 225	6 1/16 154	10 13/16 275	3 1/4 83	7 3.0
PV-125x	7 5/8 194	1 25	9 1/2 241	4 7/8 124	6 11/16 170	8 7/8 225	6 1/16 154	10 13/16 275	3 7/16 87	7 3.0
PV-150x	8 1/2 216	1 25	13 1/8 333	5 7/8 149	6 11/16 170	8 7/8 225	7 7/8 200	14 3/8 365	3 76	11 5.0
PV-200x	8 1/2 216	1 25	13 1/8 333	7 7/8 200	6 11/16 170	8 7/8 225	7 7/8 200	14 3/8 365	3 11/16 94	11 5.0
PV-250x	8 1/2 216	1 25	13 1/8 333	9 7/8 251	6 11/16 170	8 7/8 225	7 7/8 200	14 3/8 365	3 1/4 83	13 6.0

DVF-100xp Clothes Dryer Exhaust Booster Kit Installation Instructions

FIVE (5) YEAR WARRANTY

Soler & Palau warrants that the POWERVENT series exhaust fan will be free from defective materials and workmanship for the period of (5) years from the date of original purchase. In the event that we deem any part defective the product will be repaired or, in the Company's discretion, replaced without charge provided that the product has been installed in accordance with the enclosed instructions and all applicable EPA Standards and state and local building codes.

IF CLAIMING UNDER WARRANTY

Please return the complete product, freight paid, to your local authorized distributor. All returns must be accompanied by a valid Bill Of Sale. All returns must be clearly marked "Warranty Claim," with an accompanying description stating the nature of the fault.

THE FOLLOWING WARRANTIES DO NO APPLY

- Damages from shipping, either concealed or visible. Claim must be filed with the carrier.
- Damages resulting from improper wiring or installation.
- Damages caused by acts of nature, or resulting from improper consumer procedures such as:
 - Improper Maintenance
 - Misuse
 - Negligence
 - Alteration
 - Abuse
 - Abnormal Use
 - Accident or Incorrect Electrical Voltage and Current
- Removal or alteration to the Soler & Palau data plate label

WARRANTY VALIDATION

The end user must keep a copy of the Bill of Sale to verify purchase date.

THE ABOVE FIVE (5) YEAR WARRANTY IS EXPRESSLY IN LIEU OF ALL OTHER WARRANTIES, EXPRESSED, WRITTEN OR IMPLIED, INCLUDING THE WARRANTIES OF MERCHANTABILITY AND FITNESS FOR USE. IN NO EVENT SHALL SOLER & PALAU BE LIABLE FOR ANY SPECIAL, CONSEQUENTIAL, OR INCIDENTAL DAMAGES, INCLUDING LOSS OF PROPERTY, REVENUES, LOST PROFITS, AND COSTS OF REMOVAL, INSTALLATION OR REINSTALLATION. DOES NOT INCLUDE MOTOR. FAN MOTOR COMES WITH (1) YEAR LIMITED WARRANTY.