

# MODEL FF/FFC

## CEILING AND INLINE/CABINET VENTILATORS



### APPLICATION

The extremely quiet FF and FFC ventilators are used to exhaust air from a variety of commercial and institutional applications, such as restrooms, conference rooms, offices, storage areas, restaurants, retail stores, schools, and similar buildings... anywhere quiet, high-capacity ventilation is needed.

The forward curved centrifugal wheel with its high static pressure capability makes these ventilators suitable for either ducted or nonducted applications. They include removable blower assemblies and plug-in permanently lubricated motors for ease of servicing and cleaning.



S&P USA Ventilation Systems, LLC., Div. of Soler & Palau Ventilation Group, certifies that the Models FF/FFC shown herein are licensed to bear the AMCA Seal. The ratings shown are based on test and procedures performed in accordance with AMCA Publication 211 and AMCA Publication 311 and comply with the requirement of the AMCA Certified Ratings Program.

**CEILING/CABINET FANS**

<b>MODEL FF</b>		<b>Ceiling Ventilator</b>											<b>Ventilator with Motor, Grille &amp; Backdraft Damper</b>		
MODEL FF	AMPS @ 60HZ/ WATTS	RPM @ 1/8	<b>CFM / Sones at Static Pressure</b>											Average Ship Wt. Lbs	120/1/60 STOCK NO.
			0	1/10	1/8	1/4	3/8	1/2	5/8	3/4	7/8	1			
50	0.8/48	1870	52	49	47	42	29	-	-	-	-	-	4	FF50 ●	
			3.9	4.3	4.4	4.6	5.5	-	-	-	-	-			
80	0.75/48	1280	89	81	80	68	36	-	-	-	-	-	7	FF80 ●	
			3.9	3.8	3.8	3.8	3.9	-	-	-	-	-			
100	1.1/87	640	136	115	109	93	80	65	44	12	-	-	23	FF100 ●	
			0.5	0.8	0.9	1.3	1.8	2.3	3.0	3.2	-	-			
150	1.3/100	710	181	161	157	141	132	124	114	94	62	-	23	FF150 ●	
			1.3	1.4	1.5	2.2	2.6	3.1	3.6	4.1	4.6	-			
200	1.8/127	740	231	214	210	196	186	177	165	144	113	51	23	FF200 ●	
			1.6	1.8	1.7	2.3	2.9	3.5	4.1	4.9	5.3	5.3			
250	2.1/166	830	272	261	259	250	242	233	218	201	165	99	23	FF250 ●	
			2.1	2.3	2.2	2.9	3.3	3.9	4.4	4.8	5.5	5.8			
300	2.6/212	905	312	309	308	303	296	287	273	254	219	125	23	FF300 ●	
			2.8	2.9	2.9	3.3	3.5	3.9	4.3	4.7	5.1	5.6			
400	1.4/146	735	480	442	434	388	344	299	229	182	114	33	34	FF400 ●	
			2.0	2.4	2.3	2.8	3.3	3.8	4.5	4.8	5.4	5.6			
500	2.2/232	810	538	520	514	491	463	434	389	339	282	186	34	FF500 ●	
			3.0	3.1	3.3	3.6	4.0	4.4	5.0	5.7	6.2	6.7			
700	2.9/313	960	722	704	701	667	640	607	571	534	453	333	34	FF700 ●	
			4.5	4.6	4.7	4.8	5.0	5.2	5.6	6.2	7.1	7.2			
900	3.0/306	650	918	905	901	877	842	793	725	636	536	390	64	FF900 ●	
			3.8	4.0	4.1	4.0	4.2	4.3	4.4	4.9	4.5	5.3			
1500	5.0/468	955	1578	1526	1513	1438	1371	1285	1198	1103	1000	816	64	FF1500 ●	
			8.6	8.4	8.4	8.1	7.5	7.0	6.7	6.2	5.8	5.8			

Performance ratings include the effects of inlet grille and backdraft damper in the airstream. Speed (RPM) shown is nominal. Performance is based on actual speed of test. The sound ratings shown are loudness values in fan sones at 5' (1.5m) in a hemispherical free field calculated per AMCA Standard 301. Values shown are for installation Type B: free inlet fan sone levels. Performance certified is for installation Type B: Free inlet, Ducted outlet.

Ship Schedules:
● Next Day Shipment From Stock

DUE TO CONTINUING RESEARCH, S&P RESERVES THE RIGHT TO CHANGE SPECIFICATIONS WITHOUT NOTICE.  
Please refer to the General Catalog or contact the Factory for our Full Line of products available on standard shipping schedules.

# MODEL FF/FFC cont'd

## CONSTRUCTION

### Housing

- Rugged, 20 gauge galvanized steel.
- Duct connector.
- 1/2" acoustic insulation inside (except FF50, FF80 & FFC's).
- Integral automatic backdraft damper.
- Easy inline conversion available (FF100-FF1500).
- Mounting brackets for easy installation and adaptability to numerous mounting requirements.
- Factory shipped in horizontal discharge position easily converted to vertical discharge.
- FFC inline units have a removable panel which allows for easy motor access without disturbing duct work.

### Blower

- Low RPM for quiet operation, speed controllable.
- Resilient anti-vibration mounts (FF50 & FF80 rigid mount).
- Balanced, polymeric, centrifugal blower wheel for quiet, efficient performance. (Metal wheel on FFC2000 & FFC3500).
- Permanently lubricated, thermally protected motor.
- Plug in motor designed for continuous operation.

## Grille

- Conceals interior.
- Low profile styling, blends with any decor.
- White polymeric (FF50 - FF300).
- Metal finished with white enamel (FF400 - FF1500).

## ACCESSORIES

- Complete selection available, see pages 65-66.



S&P USA Ventilation Systems, LLC., Div. of Soler & Palau Ventilation Group, certifies that the Models FF/FFC shown herein are licensed to bear the AMCA Seal. The ratings shown are based on test and procedures performed in accordance with AMCA Publication 211 and AMCA Publication 311 and comply with the requirement of the AMCA Certified Ratings Program.

<b>MODEL FFC</b>		<b>Inline/Cabinet Ventilators</b>											<b>Ventilator with Motor and Duct Connectors</b>						
MODEL FFC	AMPS @ 60HZ/ WATTS	RPM @ 1/8	<b>CFM / Sones at Static Pressure</b>										Average Ship Wt. Lbs.	120/1/60 STOCK NO.					
			0	1/10	1/8	1/4	3/8	1/2	5/8	3/4	7/8	1							
100	1.0/87	760	121	108	106	97	93	86	70	44	17	-	23	FFC100 ●					
			0.5	0.7	0.7	1.1	1.4	1.8	2.1	2.4	2.6	-							
150	1.3/100	920	153	148	147	140	134	125	111	91	54	18		34	FFC150 ●				
			0.9	1.0	1.1	1.4	1.6	1.9	2.1	2.2	2.4	2.6							
200	1.8/127	865	205	196	195	190	185	175	158	135	96	47			64	FFC200 ●			
			1.7	1.9	1.9	2.1	2.3	2.4	3.0	3.3	3.4	3.4							
250	2.1/166	1005	248	245	245	241	235	224	208	183	141	84				64	FFC250 ●		
			2.0	2.3	2.3	2.8	2.8	3.2	3.4	3.6	3.9	3.8							
300	2.6/212	1145	300	294	293	285	274	259	243	214	168	113					64	FFC300 ●	
			2.9	3.0	3.1	3.3	3.4	3.5	3.6	3.7	4.0	3.9							
400	1.4/146	775	450	415	406	360	313	271	223	167	90	6.0						64	FFC400 ●
			1.4	1.6	1.6	1.9	2.2	2.6	2.9	3.4	3.6	3.9							
500	2.2/232	890	546	526	519	496	472	447	407	364	306	232	64						FFC500 ●
			2.4	2.4	3.4	3.7	3.9	3.8	3.9	4.0	4.3	4.3							
700	2.9/313	1090	704	686	681	656	631	604	575	533	480	412		64					FFC700 ●
			3.6	3.8	3.7	3.9	4.0	4.2	4.3	4.4	4.7	5.0							
900	3.0/306	810	930	902	894	853	807	754	685	587	442	300			64				FFC900 ●
			3.7	3.8	3.8	3.8	3.7	3.8	3.9	4.0	4.0	4.1							
1500	5.0/468	1055	1275	1228	1214	1152	1092	1029	958	871	764	631				64			FFC1500 ●
			6.8	6.8	6.7	6.5	6.3	6.0	6.0	6.0	6.0	6.1							

Performance ratings include the effects of backdraft damper in the airstream. Speed (RPM) shown is nominal. Performances based on actual speed of test. The sound ratings shown are loudness values in fan sones at 5" (1.5m) in a hemispherical free field calculated per AMCA Std. 301. Values shown are for installation Type D; Ducted inlet, Ducted outlet. Ratings do not include the effect of duct end correction. Performance ratings include the effects of 18 feet of round inlet duct and, if needed, a rectangular to round duct transition in the airstream. Performance certified is for Installation Type D; Ducted inlet, Ducted outlet.

<b>MODEL FFC</b>		<b>Inline/Cabinet Ventilators</b>										<b>Ventilator with Motor and Duct Connectors</b>		
MODEL FFC	AMPS @ 60HZ/ WATTS	RPM @ 1/8	<b>CFM / Sones at Static Pressure</b>										Average Ship Wt. Lbs.	120/1/60 STOCK NO.
			0	1/10	1/8	1/4	3/8	1/2	5/8	3/4	7/8	1		
2000	5.8/590	965	1891	1803	1791	1657	1508	1347	1165	808	284	-	92	FFC2000 ●
			10.3	9.8	9.4	9.0	8.6	9.1	8.9	7.0	6.7	-		

Performance ratings do not include the effects of appurtenances in the airstream. Speed (RPM) shown is nominal. Performance is based on actual speed of test. The sound ratings shown are loudness values in fan sones at 5' (1.5m) in a hemispherical free field calculated per AMCA Std. 301. Values shown are for installation Type D; Ducted inlet, Ducted outlet. Ratings do not include the effect of duct end correction. Performance certified is for Installation Type D; Ducted inlet, Ducted outlet.

DUE TO CONTINUING RESEARCH, S&P RESERVES THE RIGHT TO CHANGE SPECIFICATIONS WITHOUT NOTICE.

Please refer to the General Catalog or contact the Factory for our Full Line of products available on standard shipping schedules.

CEILING/CABINET FANS

# DIMENSIONAL DATA - CEILING VENTILATOR

FF50

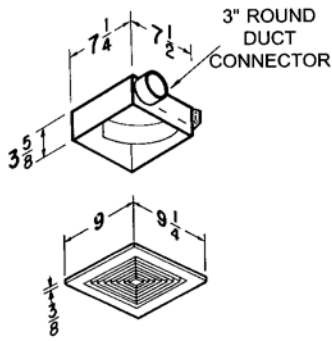

FF80

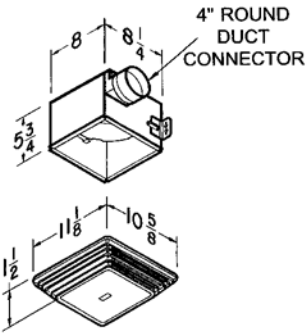

FF100 & 150

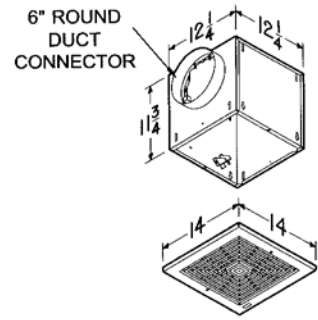

FF200, 250 & 300

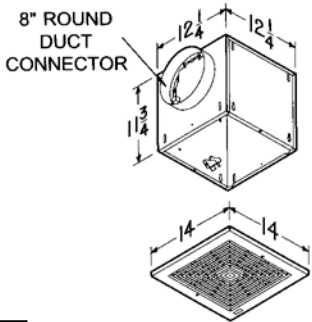

FF400, 500 & 700

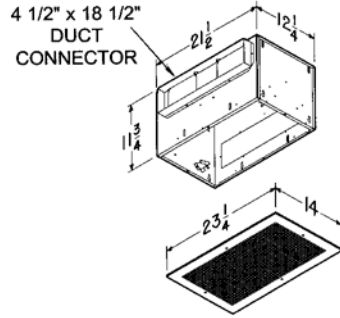

FF900 & 1500

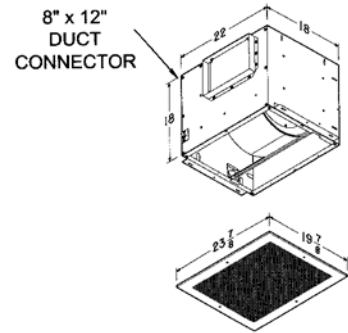

CEILING/CABINET FANS

## Inline/Cabinet Ventilator

FFC100 & 150

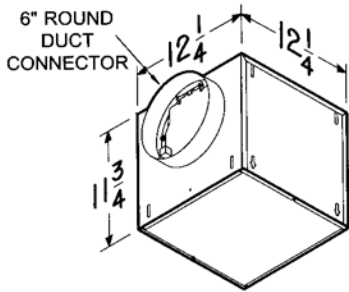

FFC200, 250 & 300

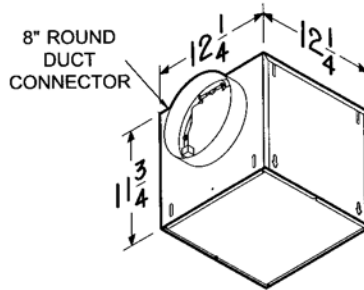

FFC400, 500 & 700

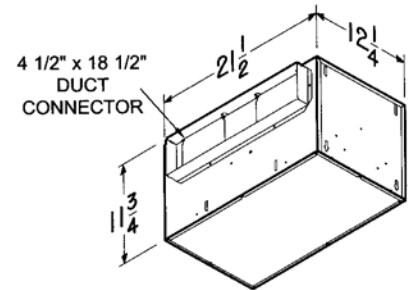

FFC900 & 1500

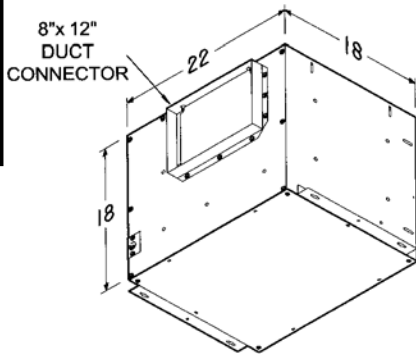

FFC2000

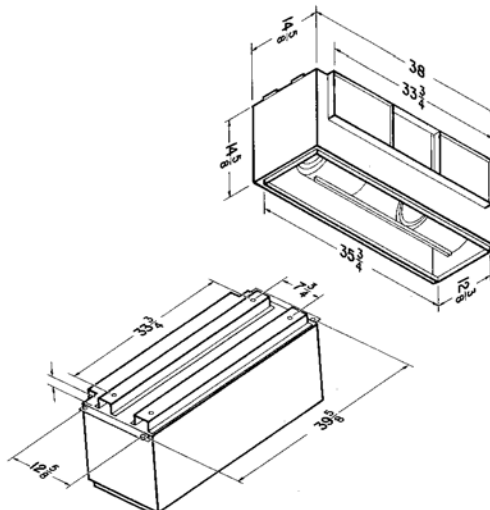

Please refer to the General Catalog or contact the Factory for our Full Line of products available

# ACCESSORIES

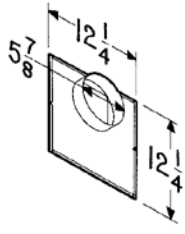

- 961L In-Line Adaptor Kit**
- Galvanized steel
  - Fits FF100 & FF150
  - For 6" round duct intake

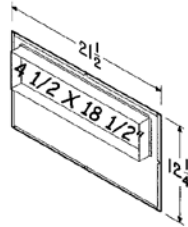

- 982L In-Line Adaptor Kit**
- Galvanized steel
  - Fits FF400, FF500 & FF700
  - 4 1/2 x 18 1/2" duct intake

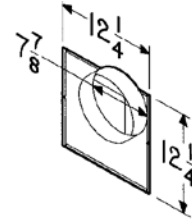

- 981L In-Line Adaptor Kit**
- Galvanized steel
  - Fits FF200, FF250 & FF300
  - For 8" round duct intake

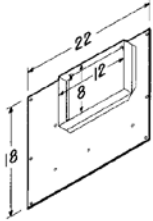

- 983 In-Line Adaptor Kit**
- Galvanized steel
  - Fits FF900 & FF1500
  - 8" x 12" round duct intake

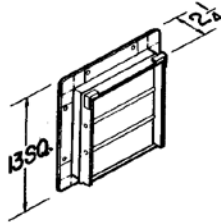

- Model 441 Wall Cap**
- Gravity dampers
  - Collar with birdscreen for attaching 10" round duct
  - Steel construction with aluminum louvers

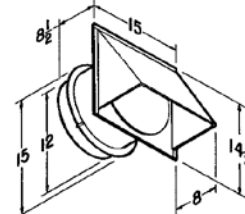

- Model 613 Wall Cap**
- High Capacity
  - Built-in backdraft damper & birdscreen
  - Aluminum natural finish
  - For 12" round duct

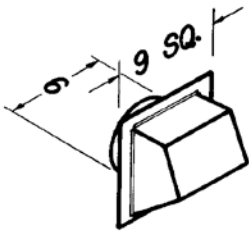

- Model 641 Wall Cap**
- Aluminum natural finish
  - Built-in backdraft damper & birdscreen
  - For 6" round duct

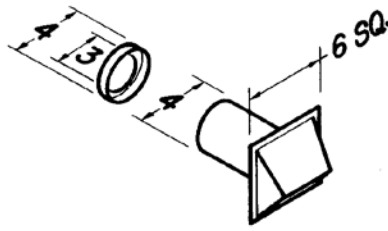

- Model 642 Wall Cap**
- Aluminum natural finish
  - Built-in backdraft damper & birdscreen
  - For 3" or 4" round duct (4" to 3" transition included)

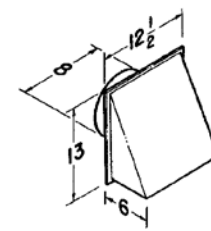

- Model 643 Wall Cap**
- Aluminum natural finish
  - Built-in backdraft damper
  - For 8" round duct

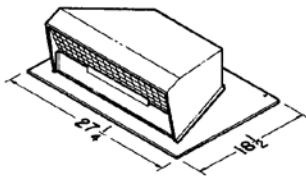

- Model 437 Roof Cap**
- High capacity design - up to 1200 CFM
  - Built-in birdscreen
  - Steel, black electrically - bonded epoxy finish

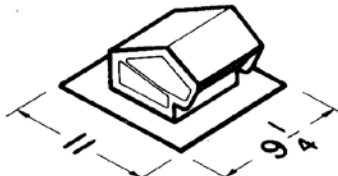

- Model 636 Roof Cap**
- Black electrically - bonded epoxy finish
  - Built-in backdraft damper & birdscreen
  - For 3" or 4" round duct

**Model 636AL - Aluminum**

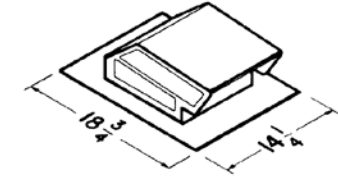

- Model 634 Roof Cap**
- Black electrically - bonded epoxy finish
  - Built-in backdraft damper & birdscreen
  - For 3 1/4" x 10" or up to 8" round duct

**Model 644 - Aluminum**

# ACCESSORIES

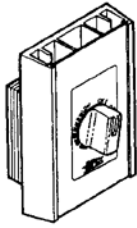

### Speed Control

- Adjust speed from 100 to 50%
- 3 amp, 5 amp & 10 amp - 120V
- 6 amp - 240V

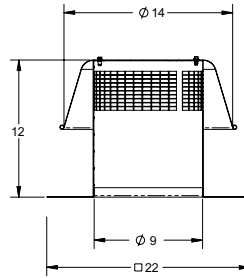

### Model RCXIIF08 Flat Roof Cap

- For flat roof installation
- Spun Aluminum - natural finish
- Built-in birdscreen
- For up to 8" round duct

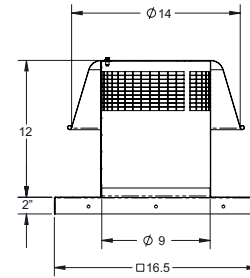

### Model RCXII08 Curb Mount Roof Cap

- For curb mount installation
- Use 14-3/4" x 14-3/4" x 12" high curb
- Spun Aluminum - natural finish
- Built-in birdscreen
- For up to 8" round duct

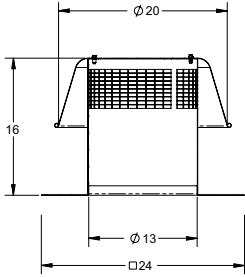

### Model RCXIIF12 Flat Roof Cap

- For flat roof installation
- Spun Aluminum - natural finish
- Built-in birdscreen
- For up to 12" round duct

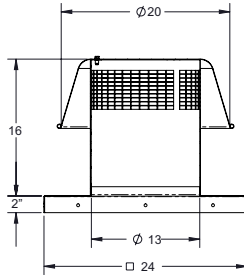

### Model RCXII12 Curb Mount Roof Cap

- For curb mount installation
- Use 22-1/4" x 22-1/4" x 12" high curb.
- Spun Aluminum - natural finish
- Built-in birdscreen
- For up to 12" round duct

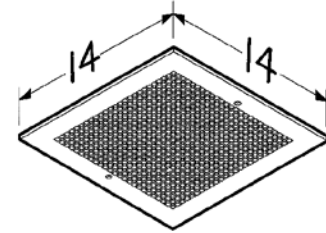

### Model MG 1 Metal Grille Kit

- White enamel painted steel
- Mounting screws included
- Fits FF100, FF150, FF200, FF250 & FF300

CEILING/CABINET FANS

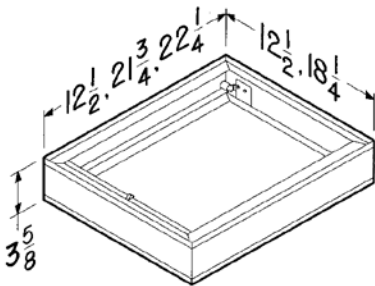

### Models RD1, RD2 & RD3 Radiation Dampers

- UL rated for use in 1, 2 or 3 hour rated floor-ceiling, roof-ceiling design
- Galvanized steel frame
- High temperature, non-asbestos, reinforced fiber thermal fabric
- 212°F fusible link
- Stainless steel negator-type closure spring
- RD1 (12 1/4" x 12 1/4") fits FF100 - FF300
- RD2 (21 1/2" x 18") fits FF400 - FF700
- RD3 (22" x 18") fits FF900 - FF1500

### Models 423 & T81212 Duct Transitions

- Galvanized steel
- Allows for quick transition to easy-to-obtain-and-install round ducting
- 423 (4 1/2" x 18" to 10 round) for use with FF400 thru FF700
- T81212 (8" x 12" to 12" round) for use with FF900 and FF1500

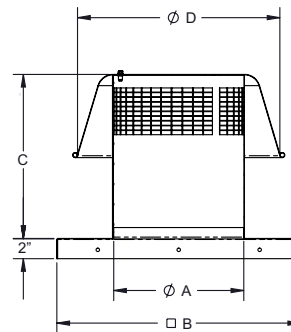
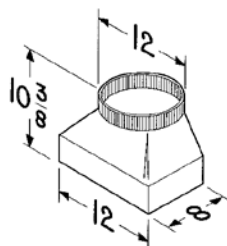
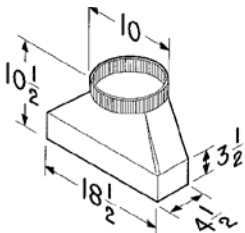

### Model RCXII - 18" and 20" units

Size	A	B	C	D
18	19	29.5	22	27
20	21	29.5	22	30

# MODEL FF/FFC

Optional Accessory Compatibility Chart

Ceiling & In-Line/Cabinet Ventilators

STOCK NO.	CEILING MOUNT MODEL FF							IN-LINE/CABINET MODEL FFC					
VARIABLE SPEED CONTROLS	FF50 FF80	FF100 FF150	FF200 FF250 FF300	FF400 FF500	FF700	FF900	FF1500	FFC100 FFC150	FFC200 FFC250 FFC300	FFC400 FFC500 FFC700	FFC900	FFC1500	FFC2000
2727.1 (5 AMP 120V) ●	X	X	X	X			X	X					
2828.1 (10AMP 120V) ●		X	X	X	X	X	X	X	X	X	X	X	X
<b>ROOF CAPS</b>													
437 ♦				X	X					X			
RCXII08SFS, RCXII08S ●	X	X	X					X	X				
RCXII12SFS, RCXII12S ●				X	X	X	X			X	X	X	X
634 ●		X	X					X	X				
636 ●	X												
RCXII18S ●													X
RCXII20S ●													X
<b>ROOF CURBS FOR RCXII08 &amp; RCXII12</b>													
611214 ●	X	X	X					X	X				
611222 ●				X	X	X	X			X	X	X	X
<b>WALL CAPS</b>													
441 ♦				X	X					X			
613 ♦						X	X				X	X	
641 ●		X						X					
642 ♦	X												
643 ●			X						X				
<b>IN-LINE ADAPTERS</b>													
961L ♦		X											
981L ♦			X										
982L ♦				X	X								
983L ♦						X	X						
<b>UL RADIATION DAMPERS</b>													
RD1 ♦		X	X										
RD2 ♦				X	X								
RD3 ♦						X	X						
<b>METAL Grille KIT</b>													
G102 ♦													X
MG1 ●		X	X										
<b>DUCT TRANSITIONS</b>													
423 ●				X	X					X			
T81212 ●						X	X				X	X	
<b>DAMPER KITS</b>													
D100 ●													X
<b>VIBRATION DAMPENING HANGERS (4)</b>													
v102 ●		X	X	X	X	X	X	X	X	X	X	X	X
<b>HEAVY DUTY</b>													
v104 ●		X	X	X	X	X	X	X	X	X	X	X	X

Ship Schedules:
● Next Day Shipment From Stock
♦ 10 Day Shipment

CEILING/CABINET FANS

Please refer to the General Catalog or contact the Factory for our Full Line of products available on standard shipping schedules.