

MODEL SDB

DOWNBLAST BELT DRIVE

CENTRIFUGAL ROOF EXHAUSTER

APPLICATION

Model SDB belt drive units are used for the exhaust of relatively clean air from a wide range of commercial, industrial and institutional environments such as manufacturing and assembly plants, office buildings, schools, hospitals, restaurants, athletic facilities and many others.

The nonoverloading wheel with its higher static pressure capabilities makes this unit suitable for either ducted or nonducted applications. Its roof mounting permits location near the area to be ventilated, allowing short duct runs and more efficient operation.

The aluminum exterior provides an attractive appearance. Belt drive results in lower operating RPM and sound levels, making the Model DB well suited to applications where quiet operation is important. Belt drive also permits easy performance adjustments when needed to balance the total ventilation system.

CONSTRUCTION

Housing

- Heavy-gauge aluminum for extra strength with prepunched mounting holes.
- Neoprene isolators for reduction of vibration and sound.
- Cover easily removed for quick access to motor compartment.
- Water tight conduit tube for easy electrical connection.
- Aluminum birdscreen and disconnect are standard.
- Lifting lugs for easy and safe placement on roof.
- Stainless steel exterior fasteners.

Centrifugal Wheel

- All aluminum backward inclined wheel.
- Nonoverloading for safe operation in ducted systems.
- Dynamically balanced for smooth operation.

Drives

- Sized for minimum 150% of drive horsepower.
- Machined cast iron adjustable motor pulleys.
- Adjustable base for belt tensioning.
- Nonstatic oil resistant v-belts.



Motors

- Single speed open drip-proof are standard.
- All motors are rated for continuous duty.
- 182T and larger motors shipped unmounted for field installation.
- Disconnect switch standard with single speed drip-proof motors.

Bearings

- Heavy-duty ball bearing type.
- Prelubricated and permanently sealed.

AMCA SEAL



S&P USA Ventilation Systems, LLC., Div. of Soler & Palau Ventilation Group, certifies that the Models SDB shown herein are licensed to bear the AMCA Seal. The ratings shown are based on test and procedures performed in accordance with AMCA Publication 211 and AMCA Publication 311 and comply with the requirement of the AMCA Certified Ratings Program.



DIMENSIONAL DATA

MODEL SDB	A	B	C	D	ROOF OPENING	Average Ship Wt. Lbs.
6	18.13	30.10	25.00	3.40	13 1/2	109
7	18.13	30.10	25.00	3.40	13 1/2	109
8	18.13	30.10	25.00	3.40	13 1/2	109
10	18.13	30.10	25.00	3.40	13 1/2	109
12	20.13	31.70	27.50	3.90	15 1/2	122
14	20.13	31.70	27.50	3.90	15 1/2	126
15	24.13	32.50	32.90	4.00	19 1/2	140
16	24.13	32.50	32.90	4.00	19 1/2	140
18	30.16	36.40	39.20	4.60	22 1/5	111
20	30.16	38.30	45.00	6.10	22 1/5	139
22	30.16	38.30	45.00	6.10	22 1/5	140

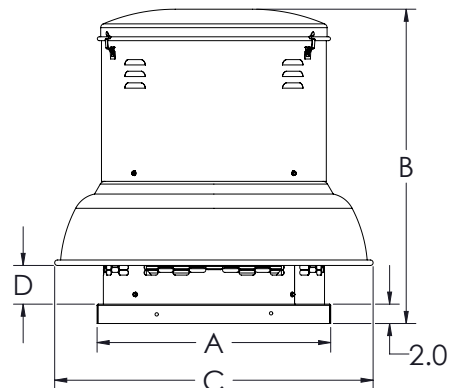

Ship Schedules:

- Next Day Shipment From Stock
- ▲ 3 Day Shipment From Stock
- ◆ 10 Day Shipment

ALL DIMENSIONS IN INCHES, WEIGHTS IN POUNDS. OD IS OUTSIDE DIMENSION OF SQUARE CURB AND DAMPER. DUE TO CONTINUING RESEARCH, S&P RESERVES THE RIGHT TO CHANGE SPECIFICATIONS WITHOUT NOTICE.

Please refer to the General Catalog or contact the Factory for our Full Line of products available on standard shipping schedules.

ACCESSORIES

MODEL SDB	RECOMMENDED 12" HIGH MOUNTING CURB		RECOMMENDED GRAVITY DAMPER		DAMPER MOTOR (LOOSE)	AUTOMATIC BELT TENSIONER (INSTALLED)
	OD	STOCK NO.	OD	STOCK NO.	STOCK NO.	STOCK NO.
6	16 1/2	711216 ●	12	411012 ●	411611 ●	100069 ●
7	16 1/2	711216 ●	12	411012 ●	411611 ●	100069 ●
8	16 1/2	711216 ●	12	411012 ●	411611 ●	100069 ●
10	16 1/2	711216 ●	12	411012 ●	411611 ●	100069 ●
12	18 1/2	711218 ●	14	411014 ●	411611 ●	100070 ●
14	18 1/2	711218 ●	14	411014 ●	411611 ●	100070 ●
15	22 1/2	711222 ●	18	411018 ●	411611 ●	100070 ●
16	22 1/2	711222 ●	18	411018 ●	411611 ●	100070 ●
18	28 1/2	711228 ●	24	411024 ●	411611 ●	100072 ●
20	28 1/2	711228 ●	24	411024 ●	411611 ●	100072 ●
22	28 1/2	711228 ●	24	411024 ●	411611 ●	100072 ●

Curb Cap adaptors are available to match old style DB and competitors curb caps. Refer to Optisizer2 for sizes available on Quickship.

MODEL SDB		Downblast Belt Drive Centrifugal Roof Exhauster														Ventilator with Open Drip-proof Motor and Drive Assembly		
		Motor Hp	Max. BHP	RPM	Sones @ 1/4 SP	CFM at Static Pressure											115/1/60*	208-230-460/3/60
						0	1/8	1/4	3/8	1/2	5/8	3/4	7/8	1	1-1/4	1-1/2	Stock No.	Stock No.
6	1/4	0.11	1,600	8.2	300	275	246	215	176	109	-	-	-	-	-	SDB06ML1S ●	SDB06ML3S ▲	
	1/4	0.15	1,800	9.7	337	315	291	265	235	201	144	80	-	-	-	SDB06MM1S ●	SDB06MM3S ▲	
	1/4	0.21	2,000	11.4	375	355	335	310	288	260	229	184	-	-	-	SDB06MH1S ●	SDB06MH3S ▲	
7	1/4	0.11	1,600	8.5	438	388	336	277	204	119	-	-	-	-	-	SDB07ML1S ●	SDB07ML3S ▲	
	1/4	0.16	1,800	10.2	493	449	402	356	300	234	158	-	-	-	-	SDB07MM1S ●	SDB07MM3S ▲	
	1/4	0.21	2,000	11.9	547	507	466	425	381	330	272	202	-	-	-	SDB07MH1S ●	SDB07MH3S ▲	
8	1/4	0.13	1,550	9.1	835	775	716	648	565	402	-	-	-	-	-	SDB08ML1S ●	SDB08ML3S ▲	
	1/4	0.19	1,750	11.1	943	888	838	782	720	646	535	-	-	-	-	SDB08MM1S ●	SDB08MM3S ▲	
	1/4	0.26	1,950	13.2	1051	1001	956	909	857	800	733	652	-	-	-	SDB08MH1S ●	SDB08MH3S ▲	
	1/3	0.33	2,100	15.0	1132	1085	1043	1000	954	905	850	787	712	-	-	SDB08PH1S ●	SDB08PH3S ▲	
10	1/4	0.19	1,450	10.8	1213	1148	1077	997	906	796	640	-	-	-	-	SDB10ML1S ●	SDB10ML3S ▲	
	1/4	0.26	1,600	12.8	1339	1280	1217	1148	1073	988	888	768	-	-	-	SDB10MH1S ●	SDB10MH3S ▲	
	1/3	0.34	1,750	14.8	1464	1411	1355	1294	1228	1158	1079	989	888	-	-	SDB10PH1S ●	SDB10PH3S ▲	
12	1/4	0.25	1,400	11.1	1540	1459	1378	1277	1170	1053	913	-	-	-	-	SDB12MH1S ●	SDB12MH3S ▲	
	1/3	0.34	1,550	13.2	1705	1632	1560	1477	1383	1286	1181	1057	885	-	-	SDB12PH1S ●	SDB12PH3S ▲	
	1/2	0.49	1,750	16.0	1925	1860	1797	1731	1653	1569	1483	1396	1296	1042	-	SDB12QH1S ●	SDB12QH3S ●	
14	1/4	0.27	1,100	10.0	2216	2081	1946	1787	1604	1324	-	-	-	-	-	SDB14MH1S ●	SDB14MH3S ▲	
	1/3	0.5	1,200	11.8	2417	2293	2172	2038	1878	1702	1427	-	-	-	-	SDB14PH1S ●	SDB14PH3S ▲	
	1/2	0.55	1,400	15.9	2820	2714	2610	2504	2388	2255	2114	1950	1714	-	-	SDB14QH1S ●	SDB14QH3S ●	
	3/4	0.75	1,550	19.0	3122	3026	2931	2838	2739	2633	2512	2385	2252	1846	-	SDB14RH1S ●	SDB14RH3S ●	
	1	1.08	1,750	23.0	3525	3440	3355	3273	3189	3102	3009	2908	2797	2568	2247	SDB14SH1S ●	SDB14SH3S ●	
15	1/4	0.26	1,000	10.0	2327	2197	2037	1870	1687	1393	-	-	-	-	-	SDB15MH1S ●	SDB15MH3S ▲	
	1/3	0.35	1,100	11.7	2560	2445	2301	2156	1996	1823	1553	-	-	-	-	SDB15PH1S ●	SDB15PH3S ▲	
	1/2	0.51	1,250	14.4	2909	2811	2691	2562	2434	2292	2149	1965	-	-	-	SDB15QH1S ●	SDB15QH3S ●	
	3/4	0.8	1,450	18.8	3375	3292	3196	3087	2976	2866	2749	2624	2502	2150	-	SDB15RH1S ●	SDB15RH3S ●	
	1	1.07	1,600	22.0	3724	3650	3567	3472	3370	3271	3172	3067	2956	2729	2412	SDB15SH1S ●	SDB15SH3S ●	
16	1/4	0.26	900	9.1	2566	2403	2219	2015	1739	-	-	-	-	-	-	SDB16MH1S ●	SDB16MH3S ▲	
	1/3	0.36	1,000	11.1	2851	2707	2544	2373	2174	1915	-	-	-	-	-	SDB16PH1S ●	SDB16PH3S ●	
	1/2	0.54	1,150	14.0	3279	3156	3019	2874	2724	2557	2345	2095	-	-	-	SDB16QH1S ●	SDB16QH3S ●	
	3/4	0.78	1,300	17.6	3707	3599	3482	3356	3228	3094	2952	2782	2585	-	-	SDB16RH1S ●	SDB16RH3S ●	
	1	1.08	1,450	22.0	4135	4038	3936	3827	3713	3597	3478	3354	3216	2875	2467	SDB16SH1S ●	SDB16SH3S ●	
	18	1/3	0.3	750	8.4	2993	2770	2542	2309	1934	1389	-	-	-	-	-	SDB18PH1S ●	SDB18PH3S ◆
1/2	0.53	900	12.0	3592	3401	3224	3027	2839	2594	2232	1816	-	-	-	SDB18QH1S ●	SDB18QH3S ●		
3/4	0.72	1,000	14.9	3991	3818	3657	3490	3313	3144	2927	2617	2279	-	-	SDB18RH1S ●	SDB18RH3S ●		
1	1.1	1,150	18.9	4590	4439	4295	4157	4008	3852	3709	3550	3352	2797	-	SDB18SH1S ●	SDB18SH3S ●		
1-1/2	1.59	1,300	22.9	5188	5054	4924	4801	4678	4546	4408	4277	4149	3832	-	SDB18TH1S ●	SDB18TH3S ●		
2	2.16	1,450	27.0	5787	5666	5548	5435	5326	5215	5098	4975	4850	4622	-	SDB18VH1S ▲	SDB18VH3S ●		
20	1/3	0.29	650	7.1	3254	2971	2685	2376	1802	-	-	-	-	-	-	SDB20PH1S ●	SDB20PH3S ◆	
	1/2	0.55	800	10.9	4006	3780	3544	3312	3059	2800	2305	-	-	-	-	SDB20QH1S ●	SDB20QH3S ●	
	3/4	0.79	900	13.4	4506	4307	4097	3893	3680	3454	3227	2921	-	-	-	SDB20RH1S ●	SDB20RH3S ●	
	1	1.08	1,000	15.7	5007	4828	4641	4452	4272	4076	3870	3676	3457	-	-	SDB20SH1S ●	SDB20SH3S ●	
	1-1/2	1.64	1,150	19.6	5758	5603	5444	5279	5115	4958	4796	4618	4440	4083	-	SDB20TH1S ●	SDB20TH3S ●	
	2	2.07	1,250	22.4	6259	6117	5971	5821	5668	5520	5376	5227	5065	4744	-	SDB20VH1S ◆	SDB20VH3S ●	
22	1/3	0.34	550	8.8	4454	3975	3399	-	-	-	-	-	-	-	-	SDB22PH1S ●	SDB22PH3S ●	
	1/2	0.57	650	11.6	5264	4863	4409	3901	2989	-	-	-	-	-	-	SDB22QH1S ●	SDB22QH3S ●	
	3/4	0.71	700	13.3	5669	5296	4892	4443	3909	-	-	-	-	-	-	SDB22RH1S ●	SDB22RH3S ●	
	1	1.06	800	16.5	6478	6151	5822	5438	5043	4570	3777	-	-	-	-	SDB22SH1S ●	SDB22SH3S ●	
	1-1/2	1.51	900	20.1	7288	6997	6709	6396	6048	5697	5291	4803	-	-	-	SDB22TH1S ●	SDB22TH3S ●	
	2	2.07	1,000	24.1	8098	7836	7576	7313	7015	6701	6387	6039	5648	-	-	SDB22VH1S ◆	SDB22VH3S ●	

Power ratings (BHP) do not include transmission losses.

Performance certified is for installation type A-free inlet, free outlet. Performance ratings include the effects of birdscreen in the airstream.

The sound ratings shown are loudness values in fan sones @ 5' (1.5m) in a hemispherical free field calculated per AMCA Standard 301.

Installation Type A: free inlet hemispherical sone levels.

*Tri-voltage (115-208-230) is standard on 3/4 through 1 1/2 Hp Single phase motors. Tri-voltage is available for the 1/2 Hp motors. Inquire for price and delivery.